

RF-Engineering

German: Hochfrequenztechnik

Kurs: Tel17NT

12. September 2019

1 RF Basics

2 System Overview

3 Fields and Waves

4 Transmission Lines

What to Expect

- Gives you an overview, why RF is a little bit different than “classical” electronics and what the specifics are.
- Prepares a common ground for RF engineering
- Explains important concepts in RF
- You will learn some aspects of the common language and basic concepts RF-engineers use to make their life easier
- Introduces dBm
- Introduces frequency usage
- Fundamentals on RF-measurements

The Spectrum

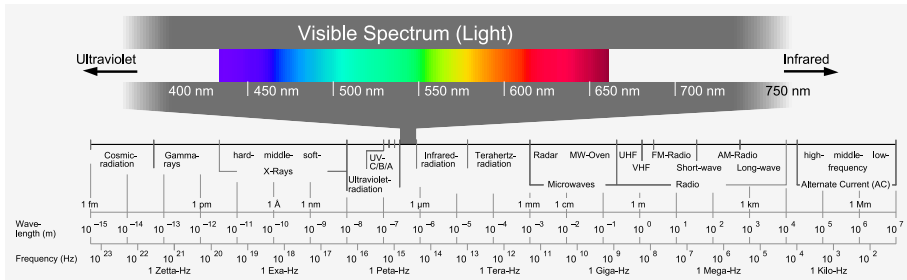

Frequency Useage I

Frequency and band on a coarse scale

Frequency	Designation	Example Use
3-30kHz	Very Low F. (VLF)	Navigation, Sonar
30-300kHz	Low F. (LF)	Radio, Navigation Aids
300-3000kHz	Medium F. (MF)	AM broadcasting, "Grenzwelle", Maritime communication
3-30MHz	High F.	Amateur radio, short wave, citizens Band, RFID
30-300MHz	Very High F. (VHF)	FM broadcasting, Television, Air traffic
300-3000MHz	Ultrahigh F. (UHF)	Television, satellite comm., surveillance radar, ISM-Applications, Microwave ovens, cellular
3-30GHz	Superhigh F. (SHF)	Airbore Radar, Microwave links, automotive radar, satellite TV
30-300GHz	Extreme High F. (EHF)	Wheather radar, automotive radar, microwave links, experimental, short range communication

Frequency Useage II

Typical Communication Bands (in Europe)

Application	Frequency/MHz	Bandw.	Modulation
Car-Key (ISM)	433.05-434.79	narrow	ASK/ FSK
GSM (D)	880-935	200 kHz	GMSK
GSM (E)	1710-1880	200 kHz	GMSK
WLAN (802.11b,g)	2400-2483.5	to 40 MHz	g:OFDM/QAM
WLAN (802.11a)	5150-5725	to 40 MHz	OFDM/QAM
UMTS/ W-CDMA	1920-2170	5 MHz	CDMA/QAM
LTE	2500-2690	to 20 MHz	OFDMA, SC-FDMA
Bluetooth	2400-2483.5	ca. 1MHz	FHSS/GFSK

Governed by Maxwell's Equations

And God said

	Differential Form	Integral Form
Ampere's circuit law	$\nabla \times \vec{H} = \vec{J} + \frac{\partial \vec{D}}{\partial t}$	$\oint_{\partial S} \vec{H} dl = I_{f,S} + \frac{\partial \Phi_{D,S}}{\partial t}$
Faraday's law	$\nabla \times \vec{E} = -\frac{\partial \vec{B}}{\partial t}$	$\oint_{\partial S} \vec{E} dl = -\frac{\partial \Phi_{B,S}}{\partial t}$
Gauss' law (el.)	$\nabla \cdot \vec{D} = \rho$	$\oiint_S \vec{D} dA = Q$
Gauss' law (mag.)	$\nabla \cdot \vec{B} = 0$	$\oiint_S \vec{B} dA = 0$

And there was light.

Consider High-Frequency-Effects

- Elements are not “lumped” anymore:
physical dimensions of elements (e.g. resistors, caps, sometimes transistors, most importantly cables and interconnects) must be considered
- Parasitics of elements must be considered
- Power is dominant measurement quantity
- Measurement equipment has effect on the device under test (DUT)
(high-ohmic vs. $50\ \Omega$)
- Field extension and (ir)radiation must be considered (coupling and antennas)

Think like an RF-Engineer!

Think in

- Waves and wavelength λ (or frequency f) $\lambda = \frac{c_0}{\sqrt{\epsilon_{eff}}} \frac{1}{f}$
 - c_0 Free space speed of light $\approx 300,000\text{km/s}$
 - ϵ_{eff} Effective dielectric coefficient (tbd later)
 - Remember: electromagnetic wave at 10 GHz has a free space wavelength of about 30 mm, 1 GHz of 30 cm...
- Wavelength in Material (e.g. ceramics with permittivity $\epsilon_r > 10$) much shorter
- It's all about matching, it's all about resonance

- Power and the unit dBm (at least mostly)
- Power-Reflection and transmission versus voltage and current

Skin-Effect

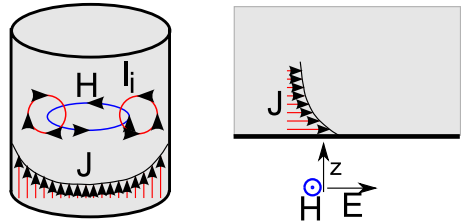

- Because of induction, magnetic field pushes current to the edges of material
- With higher frequency, current is only supported at the boundaries of conductors
- Skin-depth $\delta = \sqrt{\frac{2}{\omega\mu_0\mu_r\sigma}}$ with μ permeability, σ conductivity of the material.
- Skin-depth defines point, where current density is decreased by $1/e$
- This is why conductivity (especially at surfaces) is important

Material Parameters, Skin-Depth

$$\text{Skin-depth } \delta = 1 / \sqrt{\pi f \mu_0 \mu_r \sigma}$$

Material	$\mu \Omega \text{ cm}$	μ_r	$\delta \sqrt{f} / (\mu \text{ m} \sqrt{\text{GHz}})$
Aluminum	2.65	1	2.59
Copper	1.7	1	2.1
Iron	9.66	5000	0.07
Silver	1.59	1	2
Gold	2.44	1	2.5
μ -Metal	55	50000	0.05

Note that relative permeability for iron and μ -metal cannot be maintained at high frequencies (that's why they are not used in RF-shielding)!

Skin-Depth

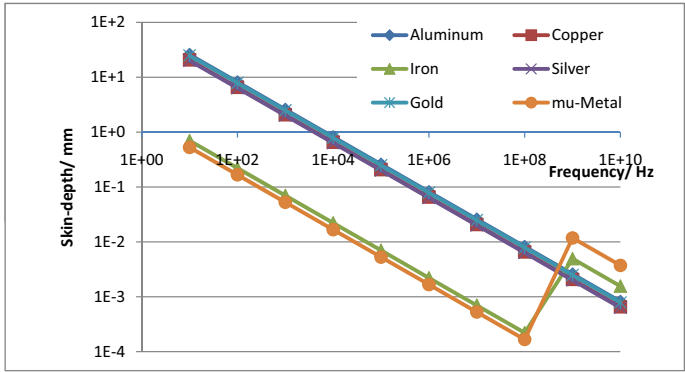

Skin-depth vs. frequency (logarithmic!) for various materials

THE Unit: dB (dezi-Bel)

Measure of relative quantities

- Power-relation: $a_P = 10 \log \frac{P_1}{P_2}$
- Voltage-relation: $a_U = 20 \log \frac{U_1}{U_2}$ (equal impedance levels on Port 1 and 2)

For absolute quantities a reference level must be introduced:

- Power (relative to 1mW): $P[\text{dBm}] = 10 \log \frac{P}{1\text{mW}}$
- Voltage (relative to 1 μ V): $U[\text{dB}\mu] = 20 \log \frac{U}{1\mu\text{V}}$

dB: What's the Ratio?

dB	Power Scale	Amplitude Scale
100	10000000000.0	100000.0
90	1000000000.0	31620.0
80	100000000.0	10000.0
70	10000000.0	3162.0
60	1000000.0	1000.0
50	100000.0	316.2
40	10000.0	100.0
30	1000.0	31.62
20	100.0	10.
10	10.0	3.162
0	1	1

dB: What's the Ratio?

dB	Power Scale	Amplitude Scale
0	1	1
-10	0.1	0.3162
-20	0.01	0.1
-30	0.001	0.03162
-40	0.0001	0.01
-50	0.00001	0.003162
-60	0.000001	0.001
-70	0.0000001	0.0003162
-80	0.00000001	0.0001
-90	0.000000001	0.00003162
-100	0.0000000001	0.00001

Calculate dB in your Head

dB	Sum/Difference of 10,5,3	Mult., Div.	Linear
0	Memorize		1
1	$10 - 3 - 3 - 3$	$10/2/2/2$	1.25
2	$5 - 3$	$3/2$	1.5
3	Memorize		2
4	$10 - 3 - 3$	$10/2/2$	2.5
5	Memorize		3
6	$3 + 3$	$2 * 2$	4
7	$10 - 3$	$10/2$	5
8	$5 + 3$	$3 * 2$	6
9	$3 + 3 + 3$	$2 * 2 * 2$	8
10	Memorize		10

A Word on Measurement

- RF Basics
- System Overview
- Fields & Waves
- Transmission Lines
- Practical TL
- 2-Port and S-Parameters
- Matching
- Antennas
- Passives
- Transistors
- Linear Amplifier
- Noise

Some simplified words of caution on measuring within RF-circuits

	DC	RF
Resistance	Meg-Ohms	50 Ohms
Probe	Does not influence	Antenna, high load
Quantity	Voltage and Current	Power/ S-parameter
Where?	where-ever	Only at defined points
Open cover	does not matter	may disturb signal

References

RF Basics

System
Overview

Fields &
Waves

Transmission
Lines

Practical TL

2-Port and
S-Parameters

Matching

Antennas

Passives

Transistors

Linear
Amplifier

Noise

System Overview

- 1 RF Basics
- 2 System Overview**
- 3 Fields and Waves
- 4 Transmission Lines
- 5 Practical TL

What to Gain

- Gives you just a brief overview how RF systems look like
- Introduces main building blocks
- Explains what to watch out for
- Gives you a red line throughout the entire course

You will be enabled to

- Identify building block
- Explain why they are there

The Transceiver

Block-diagram of a typical transceiver circuit

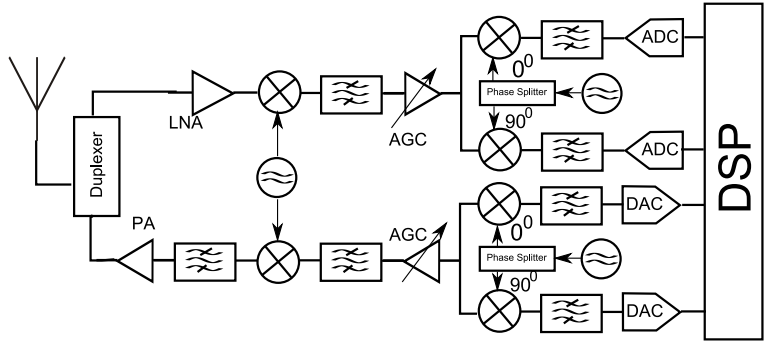

The Antenna

- Most visible part of the system
- Sometimes very critical part (e.g. because of space)
- Mainly the antenna is responsible for RF-techniques being called “black magic”
- In the end: Just a piece of conductor being smartly formed for effective irradiation or reception of electromagnetic waves.

Antennas



Different antennae pictures GPL, <http://de.wikipedia.org>

Example: SAT-TV-LNA

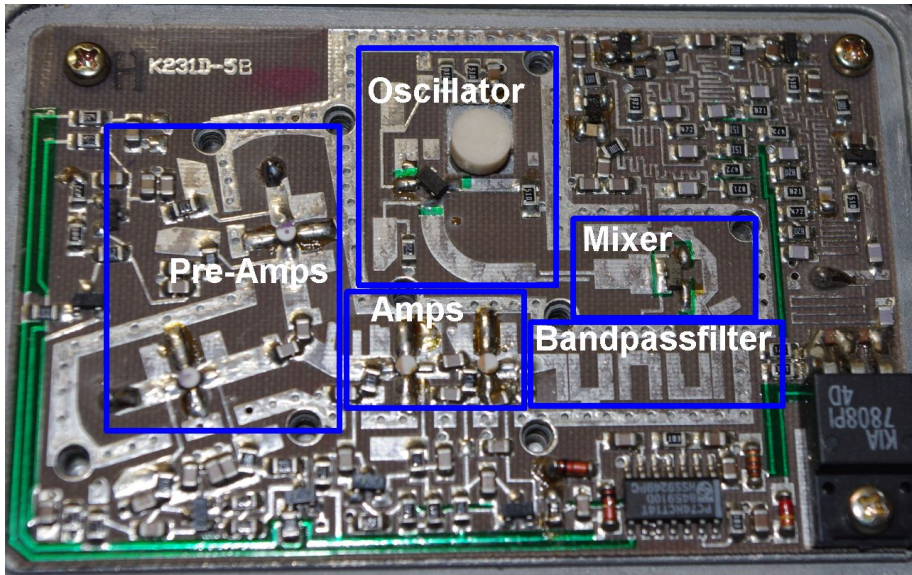

A dismantled Low Noise Amplifier for Sattelite TV

Example: Evolution of Mobile Communication



(a)

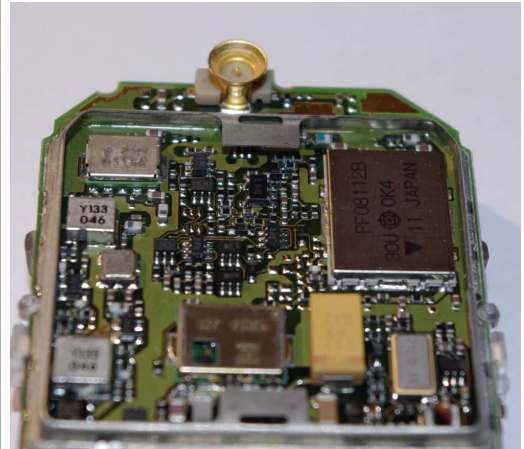

(b)

Nokia NKW1X (CDMA) with Duplexer (left) Siemens GSM C35 (right)

Example2: Evolution of Mobile Communication

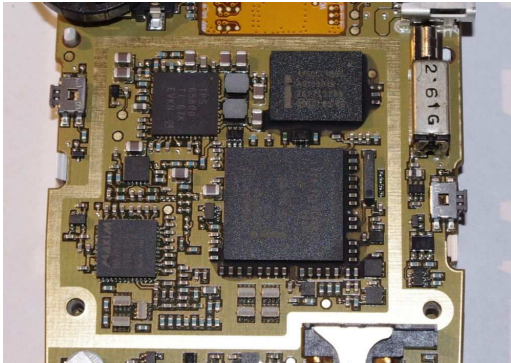

(a)

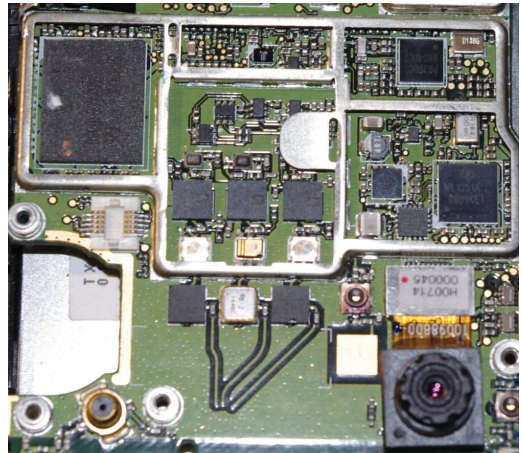

(b)

Blackberry 7130 (still all GSM) (left) ad HTC TRIN100 (3G, Multiband) (right)

More Pictures

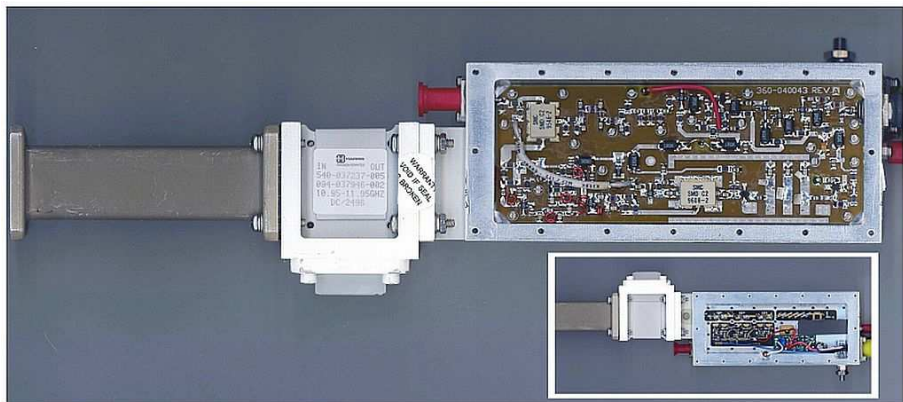

Amplifier (and periphery) for the KU-Band (12-18 GHz) (Source Wikipedia, GPL)

Basic Radar

- RF Basics
- System Overview
- Fields & Waves
- Transmission Lines
- Practical TL
- 2-Port and S-Parameters
- Matching
- Antennas
- Passives
- Transistors
- Linear Amplifier
- Noise

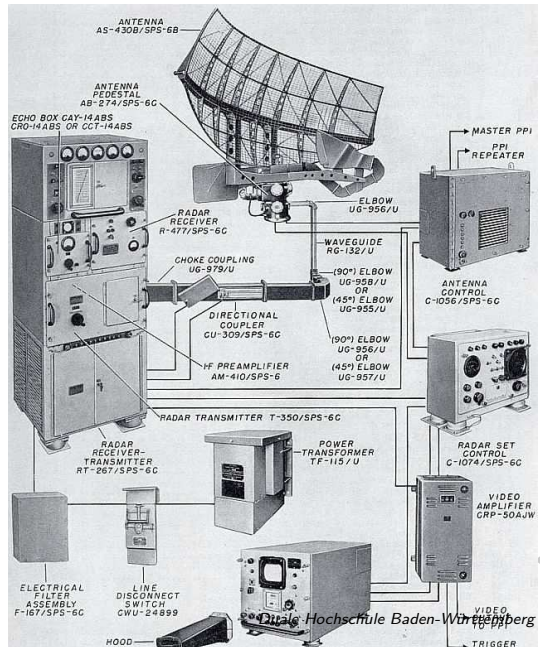

Radar: Modern and Civilian

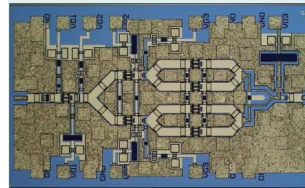
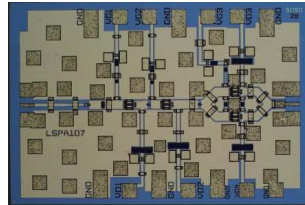
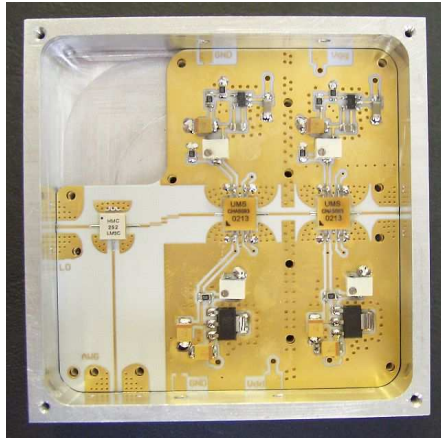

Radar application and MMIC (around 100 GHz) and system for 24 GHz

The Duplexer



- Depending on System architecture this can be completely different building block
 - Frequency Division Duplex (FDD): Differentiate between transmit (TX) and receive (RX by frequency: Use a filter structure (Duplexer))
 - Time Division Duplex (TDD). Switch between RX and TX and have them at different times: Use a switch (or a circulator)
- In general very critical (passive) element, because the first (RX) or the last (TX) element!

Simple Amplifiers

Low Noise Amplifier (LNA)

- Works on very low power: Linearity and efficiency often of second priority
- Determines sensitivity of the entire system
- Small element
- Careful: can be overdriven or even destroyed!

Power Amplifier (PA)

- High-Power delivering entity
- Linearity an issue
- Efficiency (how DC-power gets converted into RF power) is important
- Thermal considerations
- Typically expensive component

Mixer Overview

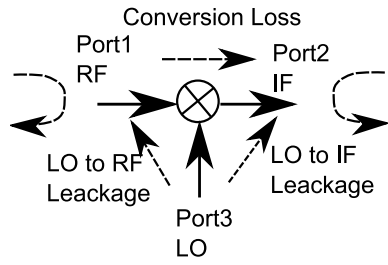

Some parameters of the mixer

- Nonlinear operation (converts the frequency)
- Often loss of power
- Requires Local Oscillator (LO) frequency and power
- Non-ideal: leaks LO power in all directions

Mixer Simple How To

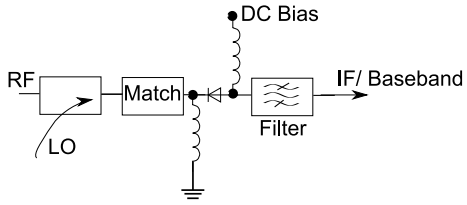

Very simple mixer with only one diode as mixing element

- DC bias responsible for bringing diode into right working point
- RF and LO must be combined and lead to the diode
- Matching tedious. Must be done for RF, LO and Intermediate frequency (IF)
- Filter appropriately

- Why?
 - Limit Noise bandwidth
 - Limit external disturbances (e.g. co-siting with different standards)
 - Enable coexistence of different systems
 - Filter out unwanted leakages (Harmonics/ Mirror, LO, IF, ...)
 - Dimensioning is sometimes very critical in pass- and stop-band!
- What is it?
 - Ceramics filter
 - Distributed ((micro-strip) line elements)
 - Cavity resonators
 - Lumped Elements (Inductors, Caps)

Automatic Gain Control (AGC)

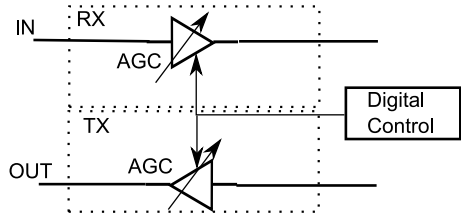

Dynamic range is vital in modern communication systems e.g. in motion, in fading channel conditions (urban environment)

- AGC required to adjust gain, thus save e.g. bits (width) in ADC/DAC, drive ADC at optimum possible level
- receiving device communicates to sender to adjust power (\times dB steps up or down)

Simple truth, every FM-radio listener knows: Transmitter/ Broadcaster and receiver must be (stably) tuned to the same frequency!

- Oscillator is essentially feed back amplifier, that then of course starts to oscillate
- Stabilization must be taken care of either
 - Lock to external source (Phase locked loop), can be on same board or as far away as GPS satellites are
 - Feedback only distinctly via resonator (crystal, dielectric resonator, cavity, LC?)
- Voltage Controlled Oscillator (VCO): Frequency changes with voltage applied at some port
- PLL is control of VCO by comparing (and adjusting) according to external reference

Modulator/ Demodulator

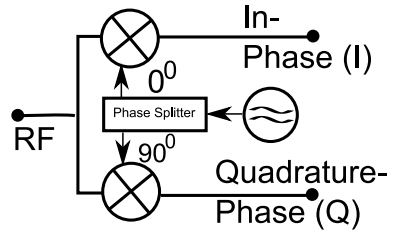

- Essentially very similar to mixer
- Task: Mix signal down to mid-frequency zero (baseband) or: extract the original signal (demodulator). Other way around: mix baseband signal up to some RF or IF (modulator)
- Mod/ demod shown here for complex (I/Q) digital signals, simpler for “old” amplitude (AM) and frequency (FM) modulation

Analog Digital Conversion (and Vice Versa)

- Interface between digital and analog signals
- Parameters:
 - Numbers of bits (digits) describe dynamic range (1 bit is factor of 2, equals 6 dB (voltage!)), thus 16 bit wide DAC/ADC has dynamic range of 96 dB
 - Speed: Determines sample rate and thus bandwidth allowed for converted (baseband) signal $f_{max} = \frac{1}{2T_s}$
 - Usually oversampling and subsequent digital filtering utilized

Evolution in Front-End Integration

Dual band
>200 RLC
10 IC
5 Filter

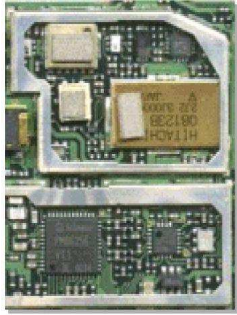

1999

Triple band
100 RLC
3 IC
3 Filter



2003

Quad band
30 RLC
2 IC
4 Filter



2006

Quad band+ UMTS
20 RLC
1 IC
6 Filter



2008

?

2010

And the Block-Diagram

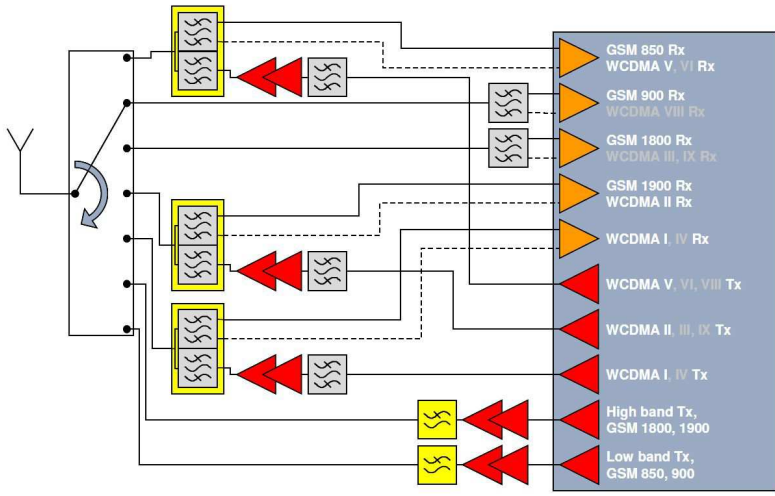

Multiband, multi-mode cellular phone [1].

Does it get Better if We Evolve to 4G?

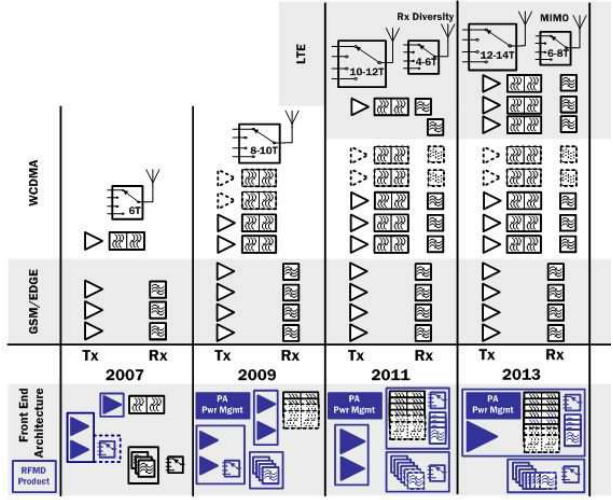

Evolution to LTE and 4G [2].

Concepts of Software Defined Radio

Illustration of basic ideas:

- Have analog/ Digital conversion at intermediate frequency (IF)
- Do modulation/ demodulation and filtering (etc.) in Digital Signal Processor (DSP)
- Advantage
 - Flexible adaption to different standards (if only processing power permits)
 - Simpler RF, digital signal processing mathematically correct, does not need (so much) calibration
 - more advanced algorithms applicable (e.g. full MIMO)
- Disadvantage
 - High sampling/ conversion speed/ bandwidth required
 - High processing power required, may be costly

Smart Antenna and MIMO

What is it?

- Multiple single antenna signals combined smartly to one, so that focusing on only one partner/ in only one direction

How is it done?

- Have a multitude of transmit/ receive paths, mostly shared oscillators required for stable phase coupling
- Amplitude and phase adjust signal from/ to each single antenna element
- In digital domain: use digital beam forming combining, just complex add and multiply

References



Agilent Technologies. *3GPP Long Term Evolution: System Overview, Product Development, and Test Challenges*. Techn. Ber. Application note 5989-8139EN under [http: www.agilent.com](http://www.agilent.com). Agilent Technologies, 2009.



Kevin Walsh und Jackie Johnson. *3G/4G Multimode Cellular Front End Challenges Part 2*. Techn. Ber. <http://www.rfmd.com>. RFMD, 2011.

Fields and Waves

1 RF Basics

2 System Overview

3 Fields and Waves

4 Transmission Lines

5 Practical TL

6 2-Port and S-Parameters

What you Learn

- See how electromagnetic fields are built
- Get an expression on fields and waves in homogeneous media
- See how fields and waves interact with matter and behave at boundary conditions
- Be able to draw fields and waves principally

Maxwell's Equations

- 3 Fields and Waves
 - Maxwell's Equations
 - Details on Maxwell's Equations
 - Fields and Media
 - The Waves and the Wave-Equation

- 4 Transmission Lines

Governed by Maxwell's Equations

And God said

	Differential Form	Integral Form
Ampere's circuit law	$\nabla \times \vec{H} = \vec{J} + \frac{\partial \vec{D}}{\partial t}$	$\oint_{\partial S} \vec{H} d\vec{l} = I_{f,S} + \iint_S \frac{\partial \vec{D}}{\partial t} d\vec{s}$
Faraday's law	$\nabla \times \vec{E} = -\frac{\partial \vec{B}}{\partial t}$	$\oint_{\partial S} \vec{E} d\vec{l} = -\iint_S \frac{\partial \vec{B}}{\partial t} d\vec{s}$
Gauss' law (el.)	$\nabla \cdot \vec{D} = \rho$	$\oiint_{\partial V} \vec{D} d\vec{s} = Q$
Gauss' law (mag.)	$\nabla \cdot \vec{B} = 0$	$\oiint_{\partial V} \vec{B} d\vec{s} = 0$

And there was light.

Maxwell's Equations

Maxwell' equations [4, 1, 3] for time-harmonic fields (i.e. $f(t) \propto e^{-j\omega t}$, ω circular frequency $2\pi f$)

Three dimensions	One dimension (z)
$\nabla \times \vec{H} = j\omega\vec{D} + \vec{J}$	$-\frac{\partial H_y}{\partial z} = j\omega D_x + J_x$
	$\frac{\partial H_x}{\partial z} = j\omega D_y + J_y$
$\nabla \times \vec{E} = -j\omega\vec{B}$	$-\frac{\partial E_y}{\partial z} = -j\omega B_x$
	$\frac{\partial E_x}{\partial z} = -j\omega B_y$
$\nabla \cdot \vec{D} = \rho$	$\frac{\partial D_z}{\partial z} = \rho$
$\nabla \cdot \vec{B} = 0$	$\frac{\partial B_z}{\partial z} = 0$

∇	$\left(\frac{\partial}{\partial x}, \frac{\partial}{\partial y}, \frac{\partial}{\partial z}\right)^T$	\vec{E}	electric field
\vec{D}	electric flux density	\vec{H}	magnetic field
\vec{B}	magnetic flux density	\vec{J}	electric current density
ρ	electric charge density		

Constants from mother nature

ϵ_0	$8.85418 \cdot 10^{-12} \text{ As/(Vm)}$ $\approx 10^{-9}/(36\pi) \text{ As/(Vm)}$	Permittivity
ϵ_r	2 ... 12 ... 80 ... 1000s ≈ 80 $\approx 1000s$	PCB, Semiconductor (usual) Ceramics (high Diel.Const.) Ceramics Water (in GHz range) Metal
μ_0	$4\pi \cdot 10^{-7} \text{ Vs/(Am)}$ $1.25664 \cdot 10^{-6} \text{ Vs/(Am)}$	Permeability
μ_r	1 700 20,000	Mostly for us Steel μ -metal

Material Equations II

- RF Basics
- System Overview
- Fields & Waves
- Maxwell's Equations**
- MWEq. Details
- Media
- Waves
- Transmission Lines
- Practical TL
- 2-Port and S-Parameters
- Matching
- Antennas
- Passives
- Transistors

$$\vec{D} = \epsilon_0 \epsilon_r(\omega) \vec{E}, \quad \vec{B} = \mu_0 \mu_r(\omega) \vec{H}$$

Continuity equation (from MWEq.) $j\omega\rho + \nabla \cdot \vec{J} = 0$.

Details on Maxwell's Equations

- RF Basics
- System Overview
- Fields & Waves
 - Maxwell's Equations
 - MWEq. Details**
 - Media
 - Waves
- Transmission Lines
- Practical TL
- 2-Port and S-Parameters
- Matching
- Antennas
- Passives
- Transistors

- 3 Fields and Waves
 - Maxwell's Equations
 - Details on Maxwell's Equations**
 - Fields and Media
 - The Waves and the Wave-Equation

- 4 Transmission Lines

Gauss's Law, Electric Flux

$$\nabla \cdot \vec{D} = \rho$$

$$\oint_{\partial V} \vec{D} d\vec{s} = Q$$

- Electric flux has charge (density) as source
- Electric flux (Field) lines can start at charge
- If no charge ($\rho = Q = 0$) electric field has no source

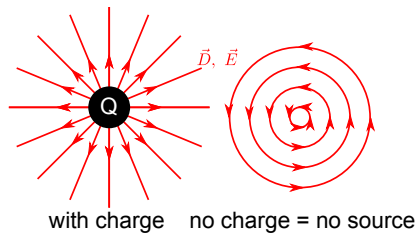

Gauss's Law, Magnetic Field

$$\nabla \cdot \vec{B} = 0$$

$$\oint_{\partial V} \vec{B} d\vec{s} = 0$$

- Magnetic flux (magnetic fields) have no sources (unless theoretically introduced)
- Magnetic field lines have no beginning and no end, they must be closed, maybe at infinity

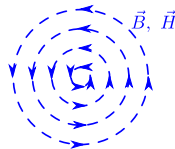

no source but curls



closing at infinity

Ampere's Circuit Law

$$\nabla \times \vec{H} = j\omega\vec{D} + \vec{J}$$

$$\oint_{\partial S} \vec{H} d\vec{l} = I_{f,S} + j\omega \iint_S \vec{D} d\vec{s}$$

- A rotation of magnetic field originates from current (density) and time-change in electric field (flux density)
- Without current: electric field is perpendicular to derivative of magnetic field
- Magnetic field strength is determined by current enclosed in integration path

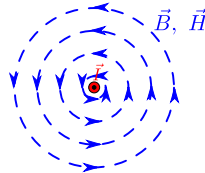

current curls magnetic field

Faraday's Law

$$\nabla \times \vec{E} = -j\omega\vec{B}$$

$$\oint_{\partial S} \vec{E} d\vec{l} = -j\omega \iint_S \vec{B} d\vec{s}$$

- A time changing magnetic flux causes curls in the electric field
- Together with Ampere's Law: Electric and magnetic fields cause each other
⇒ **electromagnetic waves**

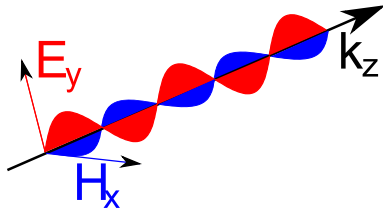

Summary on Fields and Waves

RF Basics

System
Overview

Fields &
Waves

Maxwell's Equations

MWEq. Details

Media

Waves

Transmission
Lines

Practical TL

2-Port and
S-Parameters

Matching

Antennas

Passives

Transistors

- Magnetic fields have no (monopole) sources
⇒ Magnetic field lines **must** be closed.
- Curl of magnetic field is caused by current flow
- Electric field lines start at charges, or must be closed if no charges preset
- Electric and Magnetic field can cause each other
⇒ **electromagnetic waves**

RF Basics

System
Overview

Fields &
Waves

Maxwell's Equations

MWEq. Details

Media

Waves

Transmission
Lines

Practical TL

2-Port and
S-Parameters

Matching

Antennas

Passives

Transistors

3 Fields and Waves

- Maxwell's Equations
- Details on Maxwell's Equations
- **Fields and Media**
- The Waves and the Wave-Equation

4 Transmission Lines

Homogeneous Medium, Harmonic Time

	Differential Form	Integral Form
Ampere's circuit law	$\nabla \times \vec{H} = \vec{J} + j\omega\epsilon_0\epsilon_r\vec{E}$	$\oint_{\partial S} \vec{H} d\vec{l} = I_{f,S} + j\omega\epsilon_0\epsilon_r \iint_S \vec{E} d\vec{s}$
Faraday's law	$\nabla \times \vec{E} = -j\omega\mu_0\mu_r\vec{B}$	$\oint_{\partial S} \vec{E} d\vec{l} = -j\omega\mu_0\mu_r \iint_S \vec{B} d\vec{s}$
Gauss' law (el.)	$\nabla \cdot \vec{D} = 0$	$\oint \vec{E} d\vec{s} = 0$
Gauss' law (mag.)	$\nabla \cdot \vec{B} = 0$	$\oint_{\partial V} \vec{H} d\vec{s} = 0$

- ϵ_r and μ_r virtually “increase” ω in respective formulas
 \Rightarrow in medium “time is running faster” (very loosely spoken)

Boundary Conditions

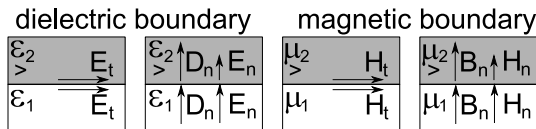

Boundary conditions on dielectric/ magnetic (possibly conducting) surfaces with normal unity vector \hat{n} [3]

- $\hat{n} \times (\vec{E}_1 - \vec{E}_2) = 0$ The tangential electric field is **continuous**.
- $\hat{n} \times (\vec{H}_1 - \vec{H}_2) = \vec{J}_s$ The tangential magnetic field "jumps" by the electric surface current and is **discontinuous**.
- $\hat{n} \cdot (\vec{D}_1 - \vec{D}_2) = \rho_s$ The normal dielectric flux "jumps" by the charge on the surface and is **discontinuous**.
- $\hat{n} \cdot (\vec{B}_1 - \vec{B}_2) = 0$ The normal magnetic flux is **continuous**

Boundary Conditions on Conductors

conductor

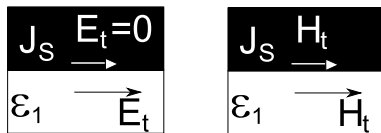

Boundary conditions on conducting surfaces with normal unity vector \hat{n}

- **Ideally conducting** $\hat{n} \times \vec{E}_1 = 0$ The tangential electric field is zero.
- **Finite conductivity** $\vec{E}_{tan1} = Z_e \vec{J}_s$ The tangential electric field can be modelled with the electric surface current and a surface resistance of the material.
- **Ideally conducting** $\hat{n} \times \vec{H}_1 = \vec{J}_s$ The tangential magnetic field is defined by the electric surface current. (induction).
- (**Finite conductivity** $\vec{H}_{tan1} = Z_m \vec{J}_m$ The tangential magnetic field can be modelled with the magnetic surface current and a surface resistance of the material.)

Effects of Boundary Conditions

The above boundary conditions give rise to all of the well-known observations at boundary conditions such as

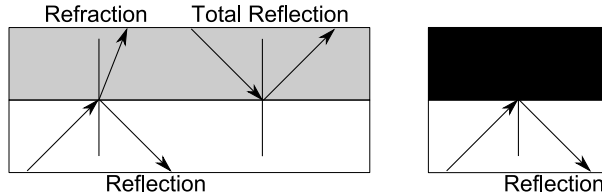

- Refraction: Change of direction of propagation, when the material (permittivity or permeability or both) changes
- Partial reflection (same thing)
- Total reflection, when a wave out of dense medium touches the surface to a less dense medium at a specific angle and under a specific polarization
- Reflection on conducting media (mirror)

The Waves and the Wave-Equation

- RF Basics
- System Overview
- Fields & Waves
 - Maxwell's Equations
 - MWEq. Details
 - Media
 - Waves**
- Transmission Lines
- Practical TL
- 2-Port and S-Parameters
- Matching
- Antennas
- Passives
- Transistors

- 3 Fields and Waves
 - Maxwell's Equations
 - Details on Maxwell's Equations
 - Fields and Media
 - The Waves and the Wave-Equation**

- 4 Transmission Lines

The Wave Equation (Derivation)

- Assume for derivation: All space is free of sources except for electrical current (and subsequently the charge)

- Curl ($\nabla \times$) of second MWEq: $\nabla \times (\nabla \times \vec{E}) = -j\omega\mu \nabla \times \vec{H}$

- Put in first $\nabla \times \vec{H} = j\omega\epsilon \vec{E} + \vec{J}$: $\nabla \times (\nabla \times \vec{E}) = -j\omega\mu (j\omega\epsilon \vec{E} + \vec{J})$

- Reorganize and use vector identity $\nabla \times (\nabla \times V) = \nabla (\nabla \cdot V) - \nabla^2 V$

- And another of MWEq $\nabla \cdot \vec{E} = \frac{q}{\epsilon} \Rightarrow \nabla \times (\nabla \times \vec{E}) = \frac{\nabla \cdot q}{\epsilon} - \nabla^2 \vec{E} = \frac{\nabla \cdot q}{\epsilon} - \Delta \vec{E}$

Wave-equation $\Delta \vec{E} + \omega^2 \epsilon \mu \vec{E} = j\omega\mu \vec{J} + \frac{\nabla \cdot q}{\epsilon}$

Or in only z-dimension $\frac{\partial^2}{\partial z^2} \vec{E} + \omega^2 \epsilon \mu \vec{E} = j\omega\mu \vec{J} + \frac{1}{\epsilon} \frac{\partial q}{\partial z}$

Solution of the Wave Equation

Only consider the one-dimensional wave-equation.

- "Guess" the solution to be $E_x = e_x e^{\pm j k_z z}$ (other vector components similar)
- Put into the wave-equation (no sources. $\vec{J} = 0$)
- $-k_z^2 e_x + \omega^2 \epsilon \mu e_x = 0$ and all other components equally.
- Hence, equation fulfilled, if only $k_z = \pm \omega \sqrt{\epsilon \mu}$,

Dimension of it is 1/m (inverse length) and so is

$$c = \frac{1}{\sqrt{\epsilon_0 \mu_0}} = 299,792,458 \text{ m/s the speed of light (in vacuum)}$$

Solution of the Wave Equation

- In principal this works for all field magnitudes and all derived potentials equally well with the same result.

- When all **three dimensions** show non-zero derivatives, there is

$$k^2 = \omega^2 \epsilon \mu = k_x^2 + k_y^2 + k_z^2$$

- A little more interesting is the solution of Maxwell's equations under certain boundary conditions.

The Plane Wave

- Suppose the wave is travelling in z-direction, so there is only a variation in z-direction and thus $\frac{\partial}{\partial x} = \frac{\partial}{\partial y} = 0$, then $\epsilon \nabla \cdot \vec{E} = \frac{\partial E_z}{\partial z} = 0$ and so $E_z = 0$
- ⇒ The electric field is **transversal**, it has only vector components perpendicular to the propagation direction.

- Further $\nabla \times \vec{E} = -j\omega\mu\vec{H} = \begin{pmatrix} \frac{\partial E_y}{\partial z} \\ -\frac{\partial E_x}{\partial z} \\ 0 \end{pmatrix} = -jk \begin{pmatrix} E_y \\ -E_x \\ 0 \end{pmatrix}$

And so the magnetic field is also **transversal** and can be calculated directly from the components of the electric field.

- This kind of wave is called a **transversal electro-magnetic** or **TEM** wave.

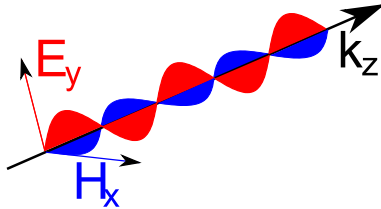

Not so Plane Wave

- $\frac{\partial}{\partial x} = \frac{\partial}{\partial y} \neq 0$,
- but in one direction (z) propagation with $\propto e^{-jk_z z}$, then

$$E_x = \frac{j}{\omega^2 \epsilon \mu - k_z^2} \left(-\omega \mu \frac{\partial}{\partial y} H_z - k_z \frac{\partial}{\partial x} E_z \right), \quad E_y = \frac{j}{\omega^2 \epsilon \mu - k_z^2} \left(\omega \mu \frac{\partial}{\partial x} H_z - k_z \frac{\partial}{\partial y} E_z \right)$$
$$H_x = \frac{-jk_z}{\omega^2 \epsilon \mu - k_z^2} \left(\frac{\partial}{\partial x} H_z - \frac{\omega \mu}{k_z} \frac{\partial}{\partial y} E_z \right), \quad H_y = \frac{-j}{\omega^2 \epsilon \mu - k_z^2} \left(k_z \frac{\partial}{\partial z} H_z + \omega \epsilon \frac{\partial}{\partial x} E_z \right)$$

Note: The components in direction of propagation (z) are enough to define the entire field.

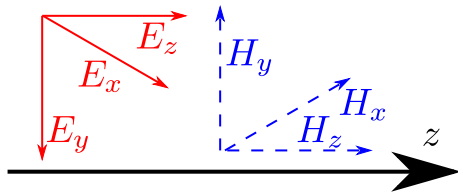

What's great about this?

- Only field components in direction of propagation are enough to define total field
- We may take the liberty to split this into two sets of solution:
 - Only magnetic component in z -direction is $H_z \neq 0$, $E_z = 0$
⇒ Transverse Electric Field (TE- or H-Field)
 - Only electric component in z -direction is $E_z \neq 0$, $H_z = 0$
⇒ Transverse Magnetic Field (TM- or E-Field)

Important classification of guided waves.

Example: TE-Wave in Parallel-Plate

Two parallel plates

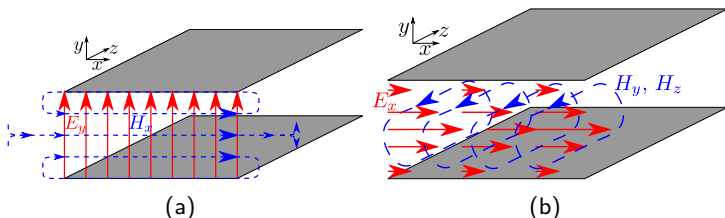

Hand-drawn TEM-field (a) and TE-field (b) in parallel-plate waveguide

- E -Field tangential zero \Rightarrow either only y -direction (a), or minimum (zero) at plates (b)
- H -Field perpendicular to $E \Rightarrow$ either in x -direction (a) or y direction at E -max (b)
- H -Field lines must close, \Rightarrow at infinity (in conductor) (a) or with H_z -component (max at E -field-min) in direction of propagation (b)

Simulated Fields in Parallel-Plate Waveguide

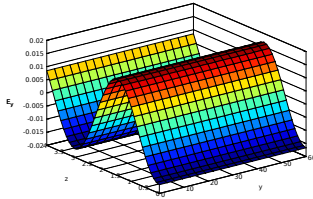

(a) TEM E_y

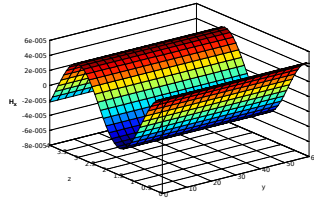

(b) TEM H_x

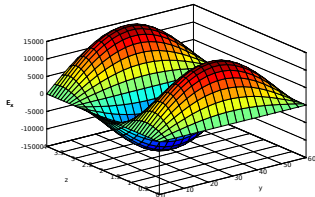

(c) TE-1 E_x

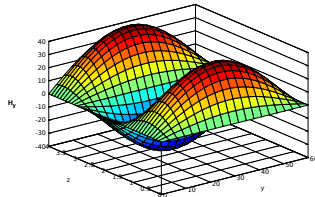

(d) TE-1 H_y

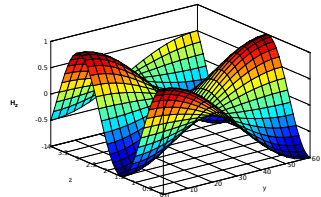

(e) TE-1 H_z

Simulated field distributions for TEM-Wave (a,b) and TE-1-Wave (c,d,e). All other

Plane Wave is Special Case

- If both $H_z = E_z = 0$ AND some other fields $\neq 0$, then
- $k_z = \omega\sqrt{\mu\epsilon}$, so denominator vanishes
- Wave has only **transverse** components (e.g. E_y and H_x , or E_x and H_y , or combination of both)
- Wave is called **Transverse Electromagnetic Wave (TEM)** as is the fact for plane wave.

Consider electrical field only in y-direction

$$(E_y \neq 0, E_x = 0 \Rightarrow H_x = j \frac{1}{\omega \mu} \frac{\partial E_y}{\partial z})$$

- With a z-propagating wave $E_y = e_y e^{-jkz}$ do partial derivative
- $H_x = h_x e^{-jkz} = -jk \frac{1}{\omega \mu} j e_y e^{-jkz}$
- We already know $k = \omega \sqrt{\epsilon \mu}$
- And so $\frac{e_y}{h_x} = \sqrt{\frac{\mu}{\epsilon}} = Z$
- **Wave-Impedance of free space** $Z_0 = \sqrt{\frac{\mu_0}{\epsilon_0}} = 120\pi \Omega \approx 377 \Omega$
- All equally valid for other constellations of field components

- Linear Polarization: $\frac{E_x}{E_y} = c$ c is a real quantity
 - Two waves with linear polarization are orthogonal (practical use: law-enforcement radio (old), terrestrial satellite TV (channel separation))
 - Drawback: If you happen to have a receiver (geometrically) turned to receive the other polarization, you are out of luck
- Circular polarization: Field components "turn" around the propagation vector. Field components $\frac{E_x}{E_y} = \pm j$ are $\pm 90^\circ$ out of phase (i.e. $E_x = 0 \rightarrow E_y = \max$, and vice versa) [2]
 - Two kinds: Right-handed ($-j$) and Left-handed (j) circular polarized waves
 - There is also some power in some component of the electric (or magnetic) field

Flow of Energy

- We already know: In plane waves, where there is electric field, there is magnetic, and they are in phase!
- For many applications (antennas are one of them) in the end we are interested in the energy flow, not particularly in electric or magnetic field.
- **Poynting-Vector** $\vec{S} = \vec{E} \times \vec{H}^*$ defines the snapshot of the energy density.

- For our TEM-wave in z-direction this is

$$\vec{S} = \begin{pmatrix} E_y H_z^* - E_z H_y^* \\ E_z H_x^* - E_x H_z^* \\ E_x H_y^* - E_y H_x^* \end{pmatrix} = \begin{pmatrix} 0 \\ 0 \\ E_x H_y^* - E_y H_x^* \end{pmatrix}$$

- So generally energy flow is only in the direction of propagation

- Power transmitted through a surface (or even closed surface) is $P = \operatorname{Re} \left\{ \frac{1}{2} \oint_S \vec{E} \times \vec{H}^* \right\}$

References

- RF Basics
- System Overview
- Fields & Waves
- Maxwell's Equations
- MWEq. Details
- Media
- Waves
- Transmission Lines
- Practical TL
- 2-Port and S-Parameters
- Matching
- Antennas
- Passives
- Transistors



R. E. Collin. *Foundations for Microwave Engineering*. 2. Aufl. McGraw Hill, 1991.



H. Meinke und F.W. Grundlach. *Taschenbuch der Hochfrequenztechnik*. 5. Aufl. Berlin: Springer, 1992.



G. Oberschmidt. *Waveletbasierte Simulationswerkzeuge für planare Mikrowellenschaltungen*. Bd. 293. 9. Düsseldorf: VDI Fortschritt-Berichte, 1998.



J. A. Stratton. *Electromagnetic Theory*. McGraw Hill, 1941.

Transmission Lines

RF Basics

System
Overview

2 System Overview

Fields &
Waves

3 Fields and Waves

**Transmission
Lines**

4 Transmission Lines

Stubs
Smith Diagram

Practical TL

5 Practical TL

2-Port and
S-Parameters

6 2-Port and S-Parameters

Matching

7 Matching

Antennas

Passives

Transistors

Linear

Amplifier

- Characterize Transmission Lines by their idealized properties (Impedance Z and propagation coefficient γ)
- Know how to deal with lossy transmission lines
- Convert Transmission line in resistor, cap, and inductor
- Understand wave propagation (incident, reflected, and transmitted)
- Understand impedance transformation (impedance transformers)
- get to know commonly used real world transmission lines

Transmission Line Theory

Essentially, in classical electronics lines are considered as wires and do not matter. (to be more exact: of course resistance (loss) and delay do matter)

For fast signals (i.e. high frequencies) this is much different. Whenever the length of the line is within reach of the wavelength (this starts between $l > \lambda/20$ or the latest $l > \lambda/10$) the nature of transmission lines needs to be considered and that is

- Dispersion: Some frequencies are transmitted “faster” than others, thus pulses change their shape
- Travelling waves and transformation: voltages, that you see at the beginning of the line might not be, what you have at the other side
- Attenuation

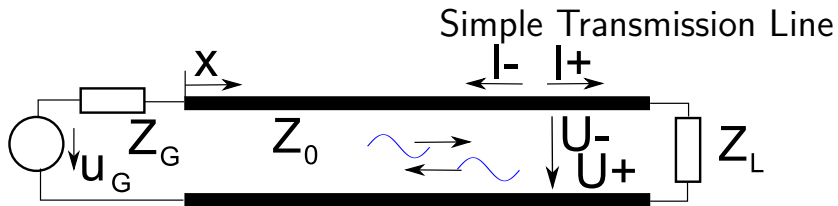

At each position x we find the following general conditions:

- Voltages: $u(x) = u_+(x) + u_-(x)$
- Currents: $i(x) = i_+(x) - i_-(x)$
- Relation between the two: $u_+ = Z_0 i_+$ and $u_- = Z_0 i_-$

Note that the introduction of forward and backward travelling waves makes physical sense, but, in general, is somewhat arbitrary. We could have done it differently, much of this is just that: Convention!

At each beginning and end of the line we have

- Beginning: $u(0) = u_G + Z_G i(0)$

The Line: Microscopic View

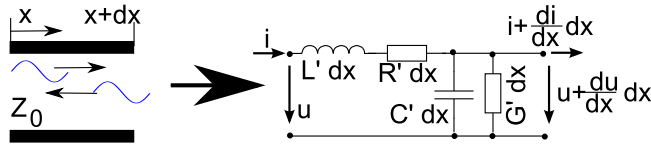

Set up the System of Differential Equations

- Voltage drop on $L' dx$ and $R' dx$

$$-\frac{\partial u}{\partial x} dx = i R' dx + \frac{\partial i}{\partial t} L' dx$$
- First Deq: $\frac{\partial u}{\partial x} = -R' i - L' \frac{\partial i}{\partial t}$
- Drop in current analogue on $G' dx$ and $C' dx$

$$-\frac{\partial i}{\partial x} dx = u G' dx + \frac{\partial u}{\partial t} C' dx$$
- Second Deq: $\frac{\partial i}{\partial x} = -G' u - C' \frac{\partial u}{\partial t}$
- These are the Telegrapher's Equation

The Wave-Equation

The system of differential equations can be combined into one, which is then the **Wave-Equation**

- Derivative to z of first equation $\frac{\partial^2 u}{\partial x^2} = -R' \frac{\partial i}{\partial x} - L' \frac{\partial}{\partial x} \frac{\partial i}{\partial t}$
- Build the derivative (to t) of the second: $\frac{\partial}{\partial t} \frac{\partial i}{\partial x} = -G' \frac{\partial u}{\partial t} - C' \frac{\partial^2 u}{\partial t^2}$
- And putting it all together: $\frac{\partial^2 u}{\partial x^2} = R' G' u + (R' C' + L' G') \frac{\partial u}{\partial t} + L' C' \frac{\partial^2 u}{\partial t^2}$
- Much simplified for no losses ($R' = G' = 0$)

$$\frac{\partial^2 u}{\partial x^2} = L' C' \frac{\partial^2 u}{\partial t^2}$$
- **This is the Wave-Equation**

Numerical Solution of the DeqS: Like FDTD I

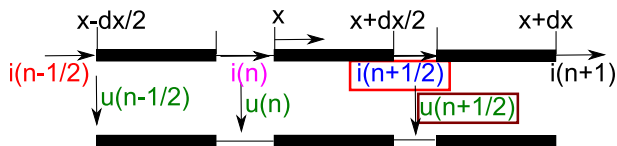

Time-step m and $m-1/2$ to $m+1/2$
 Time-step m and $m+1/2$ to $m+1$
 (boxed) values are calculated, others
 given from previous steps

Discretization of System of differential equations in x_n , N grid-steps and t_m , M time-steps

- For simplification omit losses: $\frac{\partial i}{\partial t} = -\frac{1}{L'} \frac{\partial u}{\partial x}$, $\frac{\partial u}{\partial t} = -\frac{1}{C'} \frac{\partial i}{\partial x}$
- Finite differences (step one): $\frac{i(n+\frac{1}{2}, m+\frac{1}{2}) - i(n+\frac{1}{2}, m-\frac{1}{2})}{\Delta t} = -\frac{1}{L'} \frac{u(n+\frac{1}{2}, m) - u(n-\frac{1}{2}, m)}{\Delta x}$
 $i(n+\frac{1}{2}, m+\frac{1}{2}) = i(n+\frac{1}{2}, m-\frac{1}{2}) - \frac{\Delta t}{L' \Delta x} (u(n+\frac{1}{2}, m) - u(n-\frac{1}{2}, m))$

Numerical Solution of the DeqS: Like FDTD II

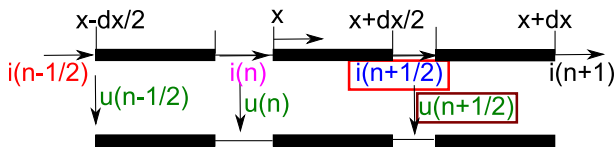

Time-step m and $m-1/2$ to $m+1/2$
 Time-step $m+1/2$ to $m+1$
 (boxed) values are calculated, others
 given from previous steps

- Finite differences (step two):
$$\frac{u(n+\frac{1}{2},m+1)-u(n+\frac{1}{2},m)}{\Delta t} = -\frac{1}{C'} \frac{i(n+\frac{1}{2},m+\frac{1}{2})-i(n-\frac{1}{2},m+\frac{1}{2})}{\Delta x}$$

$$u(n+\frac{1}{2},m+1) = u(n+\frac{1}{2},m) - \frac{\Delta t}{C'\Delta x} (i(n+\frac{1}{2},m+\frac{1}{2}) - i(n-\frac{1}{2},m+\frac{1}{2}))$$
- This is now one time-step forward. Scheme is like (not equal to) the **Finite Differences Time Domain** scheme (Yee).

Remarks on FDTD

- Conceptually VERY simple (even if you like to smile now)
 - No Matrix solution involved
 - Entire space (rigorously this means all space) must be discretized
- ⇒ Quite memory and time consuming
- Stability issues, therefore (v_{max} is maximum phase velocity)
$$v_{max} \Delta t \leq \sqrt{\Delta x^2 + \Delta y^2 + \Delta z^2}^{-1}$$
- ⇒ Small grid requires small time-steps (time and memory)
- Frequency response must be extracted
 - With smart excitation (chirp-pulse) entire frequency range can be calculated in one shot
 - Perfectly (matched) boundary conditions required to simulate free space
 - Limited by the grid, all configurations (material-steps etc.) can be simulated, no restrictions.

The Line: Microscopic View

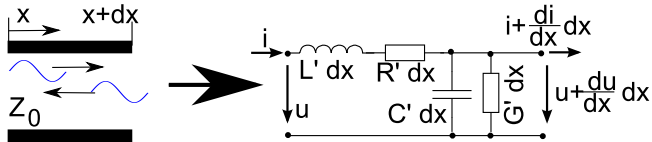

- Distributed elements: L', C', R', G' ; ideally (lossless) $R' = G' = 0$
- Solution of DGL yields (lossy case)

$$u(x) = U_+ e^{-\gamma x} + U_- e^{+\gamma x}; i(x) = I_+ e^{-\gamma x} - I_- e^{+\gamma x}$$

with propagation coefficient

$$\gamma = \alpha + j\beta = \sqrt{(R' + j\omega L')(G' + j\omega C')} \approx j\omega \sqrt{L'C'}$$

- Subsequently for characteristic impedance

$$Z_0 = \sqrt{\frac{R' + j\omega L'}{G' + j\omega C'}} \approx \sqrt{\frac{L'}{C'}}$$

For ease of use we introduce the reflection coefficient

$$\Gamma_L = \frac{u_-(l)}{u_+(l)} = \frac{Z_L - Z_0}{Z_L + Z_0}$$

from system of equations above. This is valid for the voltages and the currents, you might see slightly different reflection coefficients elsewhere in some literature.

Reflection leads to standing waves on the transmission lines:

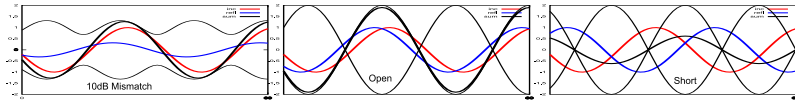

Brief animation!

Definition of VSWR

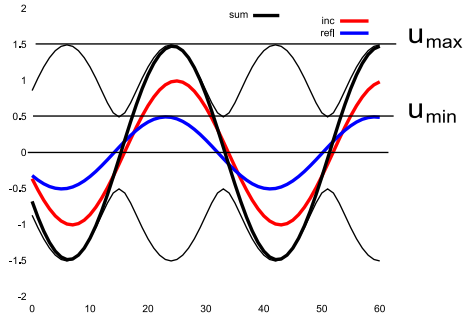

- VSWR stands for voltage standing wave ratio and means the ratio of the min and max voltage of the standing wave

- Definition

$$VSWR = \frac{u_{max}}{u_{min}} = \frac{1 + |\Gamma|}{1 - |\Gamma|}$$

- Range: 1 for perfect match, ∞ for short or open

Load Transformation I

Impedance on transmission-lines at a distance l from the load is (lossless case) described by:

$$Z_{in} = Z_c \frac{Z_L + jZ_c \tan \beta l}{Z_c + jZ_L \tan \beta l}$$

Special cases

Load Transformation II

	$l = \lambda/2$	$l = \lambda/4$
$\tan \beta l$	0	∞
Z_{in}	$Z_{in} = Z_L$	$Z_{in} = Z_c^2 / Z_L$
$Z_L = 0$ (short)	$Z_{in} = 0$	$Z_{in} = \infty$ (open)
$Z_L = \infty$ (open)	$Z_{in} = \infty$	$Z_{in} = 0$ (short)
	Z_{in} at Open	Z_{in} at Short
	$-j \frac{Z_c}{\tan \beta l}$	$j Z_c \tan \beta l$

Hence, a quarter-wavelength line can be used as a transformer, for impedance matching, and especially in bias networks for active elements (to be seen later).

Two-Port Parameters of Lines I

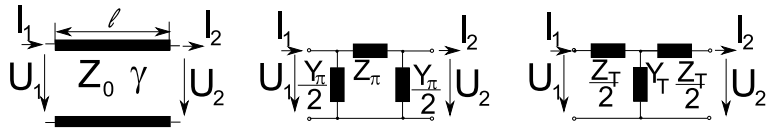

Transmission line and T- and Pi-equivalent circuit

- A transmission line is (abstractly) nothing else than a symmetrical two-port
- All symmetrical two-ports can be expressed as T- or Pi-equivalent circuits. Possibly (or rather certainly) the elements are strongly frequency dependent!

Two-Port Parameters of Lines II I

- The Π -ckt has equations

$$U_2 = U_1 \left(1 + \frac{1}{2} Z_\pi Y_\pi \right) + Z_\pi I_1$$

$$I_2 = I_1 \left(1 + \frac{1}{2} Z_\pi Y_\pi \right) + U_1 Y_\pi \left(1 + \frac{1}{4} Z_\pi Y_\pi \right)$$

- At the same time the line-equations in mathematical form are

$$U_2 = U_1 \cosh \gamma l + Z_0 I_1 \sinh \gamma l$$

$$I_2 = I_1 \cosh \gamma l + \frac{U_1}{Z_0} \sinh \gamma l$$

Two-Port Parameters of Lines II II

- Finally we find (summarized for both eq.ckt.)

$$Z_{\pi} = Z_0 \sinh \gamma l \quad Y_{\pi} = \frac{2}{Z_0} \tanh \frac{\gamma l}{2}$$

$$Y_T = \frac{1}{Z_0} \sinh \gamma l \quad T_T = 2Z_0 \tanh \frac{\gamma l}{2}$$

Electrically Short Transmission Lines

The above derived equivalent circuits are especially interesting for short transmission lines (i.e. $\gamma l \ll \lambda$)

In that case the hyperbolic functions are approximated as $\sinh \gamma l \approx \gamma l$, $\cosh \gamma l \approx 1$, $\tanh \frac{\gamma l}{2} \approx \frac{\gamma l}{2}$

And so we obtain $Z_\pi \approx Z_0 \gamma l \approx j\omega \sqrt{\epsilon_r \epsilon_0 \mu_0} Z_0 l$ which looks very much like an inductance, and $Y_\pi \approx \gamma l / Z_0 \approx j\omega \sqrt{\epsilon_r \epsilon_0 \mu_0} / Z_0 l$ which looks like a capacitance.

Which is dominant is mostly dependent on Z_0 . For large Z_0 there is a dominant series inductance with small (parasitic) shunt capacitance. For a small Z_0 we see capacitive behavior with parasitic inductance.

Similar here are the parameters of the T-equivalent circuit: $Y_T \approx 1/Z_0 \sinh \gamma l \approx j\omega \sqrt{\epsilon_r \epsilon_0 \mu_0} Z_0$, again, this is a capacitance and also $Z_T \approx Z_0 \gamma l \approx j\omega \sqrt{\epsilon_r \epsilon_0 \mu_0} / Z_0$. The latter is now the missing (evtl. parasitic) inductance.

These figures are much used in design of low-pass filters as we will see later.

- 4 Transmission Lines
 - Stubs
 - Smith Diagram

- 5 Practical TL

Use of Stubs: Shorted Stub

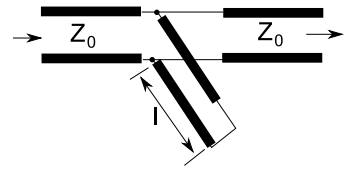

ideal representation

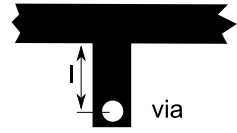

In micro-strip

- Short transformed to “throughpassing” line whenever $l = n \frac{\lambda_{eff}}{2} + \frac{\lambda_{eff}}{4}$ with $n = 0, 1, 2, \dots$
- This effectively “opens” the line
- Represents band stop for those frequencies fulfilling $l = n \frac{\lambda_{eff}}{2}$

Use of Stubs: Open Stub

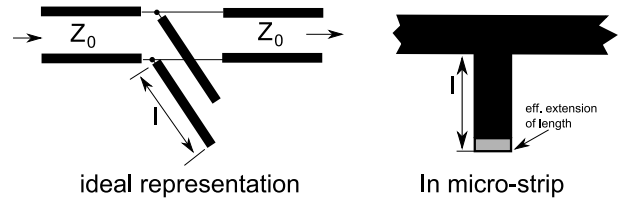

- Open transformed to “throughpassing” line whenever $l = n \frac{\lambda_{eff}}{2}$ with $n = 0, 1, 2, \dots$
- This effectively - again - “opens” the line
- Represents band stop for those frequencies fulfilling $l = n \frac{\lambda_{eff}}{2} + \frac{\lambda_{eff}}{4}$.

Stubs: Frequency Response

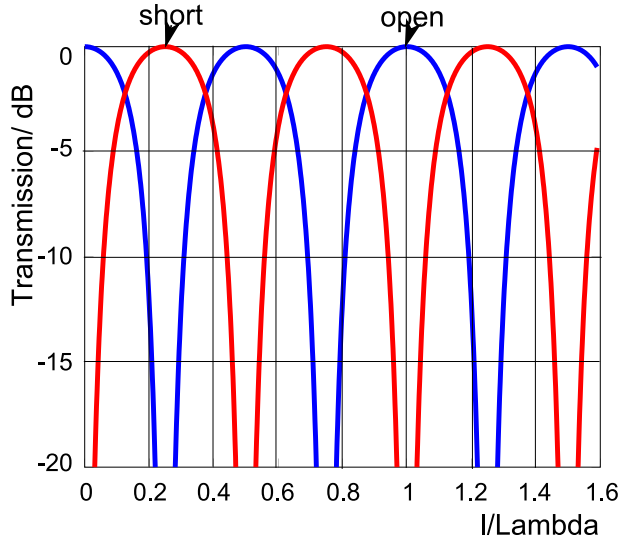

Frequency response of parallel shorted (red) and open (blue) stubs.

Please note the sharp bandstop character of the mentioned circuits.

Smith Diagram

4 Transmission Lines

- Stubs
- **Smith Diagram**

5 Practical TL

Smith Diagram

What is it?

- ① Plot the complex reflection coefficient (real-part = x-axis, imaginary-part = y-axis)
- ② Draw lines of special cases of terminations; exploit the equation $\Gamma = \frac{Z/Z_0 - 1}{Z/Z_0 + 1}$
- ③ These special cases lead to circles in the reflection-coefficient plane (e.g. all terminations with $\text{Re}\{Z/Z_0\} = 0; 1; \dots$ describe a circle). The same for the imaginary part! These are the streets you travel on, when you add cap, ind or res to the load!
- ④ Use it: When the reflection factor has been plotted, by checking the neighboring lines for different loads you can estimate the impedance that has lead to this reflection without a calculator!
- ⑤ When modifying the load, you can immediately estimate on what curve in the reflection coefficient will change (curve of constant resistor, changed inductor values etc.)

Smith Diagram

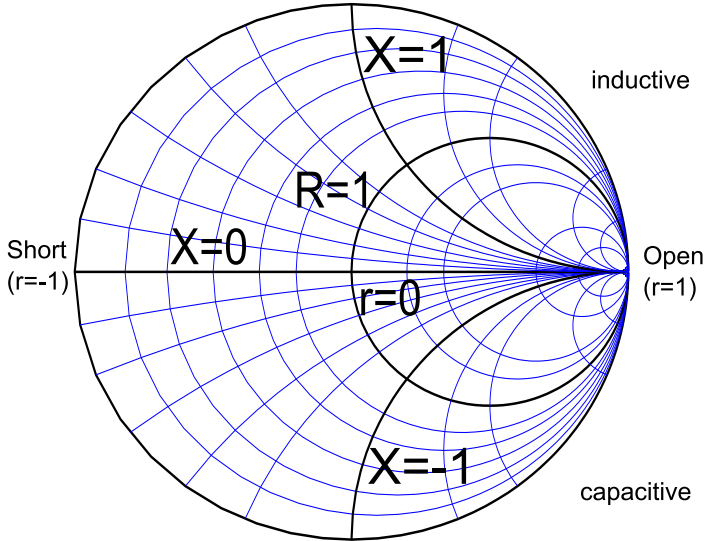

- RF Basics
- System Overview
- Fields & Waves
- Transmission Lines
- Stubs
- Smith Diagram**
- Practical TL
- 2-Port and S-Parameters
- Matching
- Antennas
- Passives
- Transistors
- Linear

Original Smith I

- RF Basics
- System Overview
- Fields & Waves
- Transmission Lines
- Stubs
- Smith Diagram
- Practical TL
- 2-Port and S-Parameters
- Matching
- Antennas
- Passives
- Transistors
- Linear

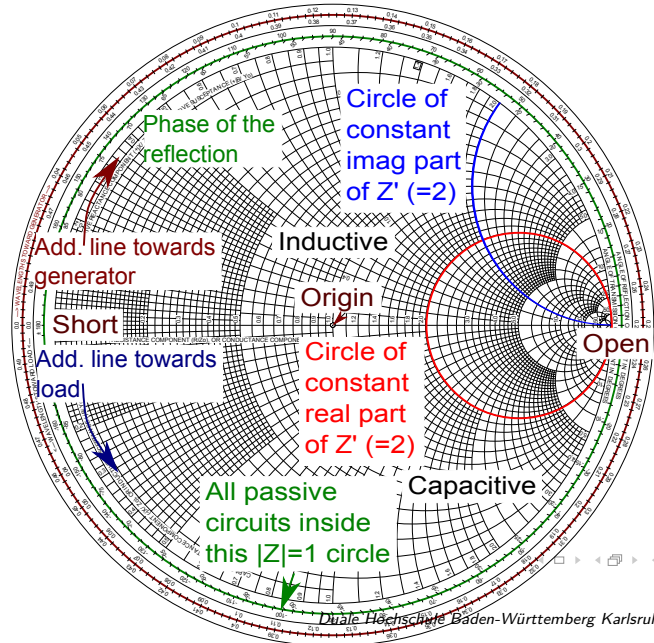

Original Smith II

- RF Basics
- System Overview
- Fields & Waves
- Transmission Lines
- Stubs
- Smith Diagram**
- Practical TL
- 2-Port and S-Parameters
- Matching
- Antennas
- Passives
- Transistors
- Linear

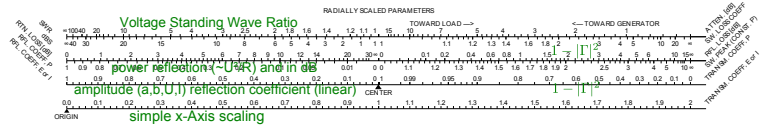

Lower part of smith diagram (transfer distance from origin to here)

Lumped Elements in Smith Diagram

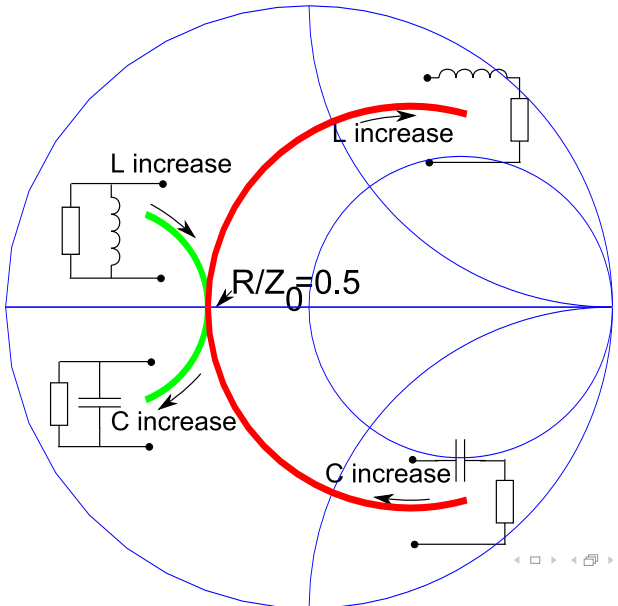

- RF Basics
- System Overview
- Fields & Waves
- Transmission Lines
- Stubs
- Smith Diagram**
- Practical TL
- 2-Port and S-Parameters
- Matching
- Antennas
- Passives
- Transistors
- Linear

RF Basics

System
Overview

Fields &
Waves

Transmission
Lines

Practical TL

Waveguides

Planar Waveguides

Coupling

PCB-Testing

2-Port and
S-Parameters

Matching

Antennas

Passives

Transistors

3 Fields and Waves

4 Transmission Lines

5 Practical TL

6 2-Port and S-Parameters

7 Matching

8 Antennas

Zoo of Lines

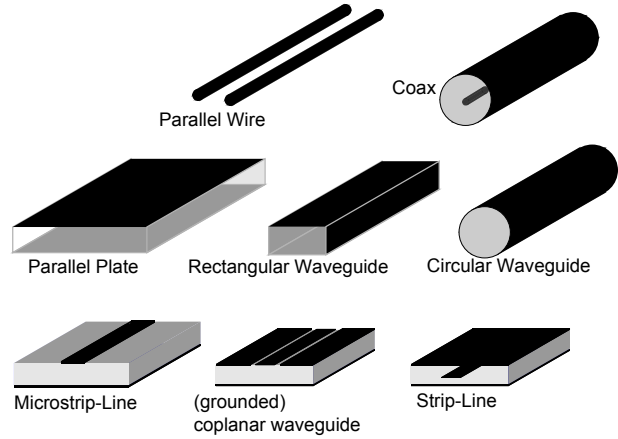

Some waveguiding (line) structures. There are many more!

- RF Basics
- System Overview
- Fields & Waves
- Transmission Lines
- Practical TL
 - Waveguides**
 - Planar Waveguides
 - Coupling
 - PCB-Testing
- 2-Port and S-Parameters
- Matching
- Antennas
- Passives
- Transistors

- 5 Practical TL**
 - Waveguides**
 - Planar Waveguides
 - Coupling
 - PCB-Testing
- 6 2-Port and S-Parameters

Simple Line: Two Parallel Plates

Parallel-Plate Waveguide

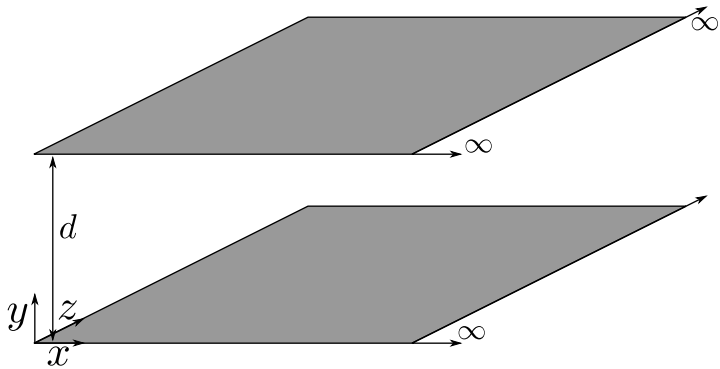

Two infinitely extended (in x, z directions) perfectly electric conducting plates.
What does the field look like?

PPWG: Simplest Field Solution TEM

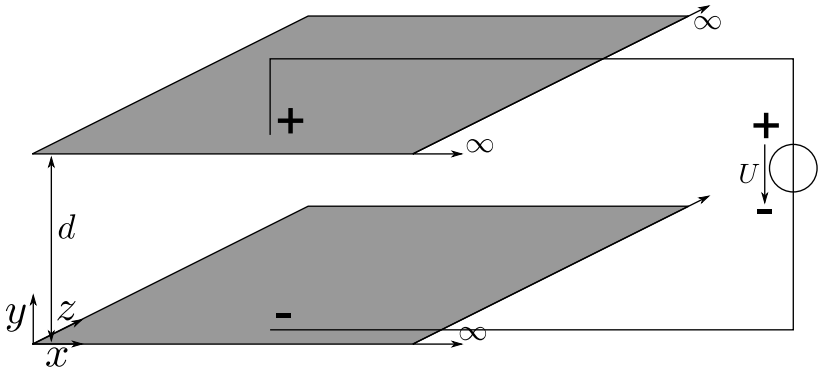

- Set plates to different potential
- Possible, because plates are isolated

PPWG: Simplest Field Solution TEM

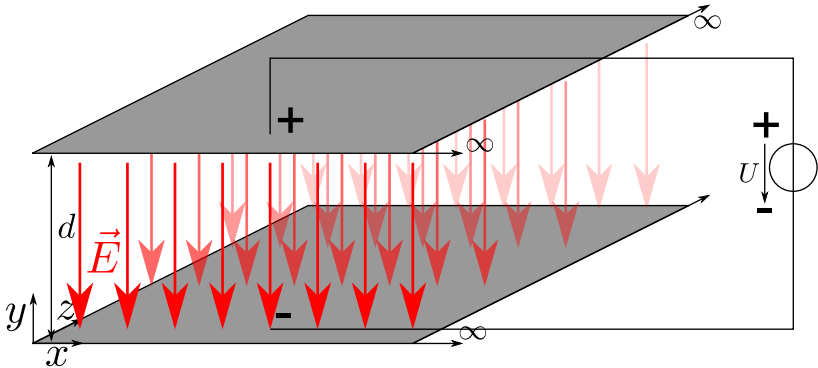

- Homogeneous electric field
- Homogeneous magnetic field (not shown)
- No component in direction of propagation: **TEM**

PPWG: TEM Field distribution

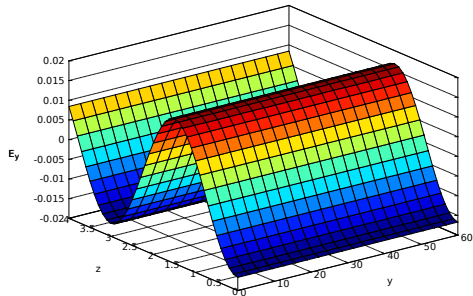

(a) TEM E_y

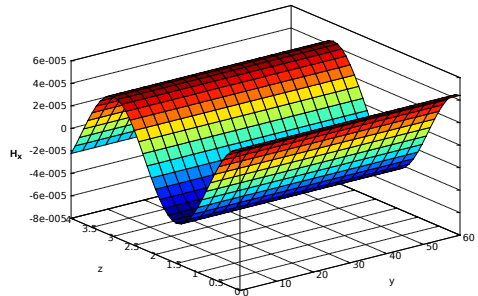

(b) TEM H_x

Field distribution for Parallel Plate Waveguide TEM-Wave

The solution is

$$E_y = -\frac{U}{d} \times e^{-jkz}$$
$$H_x = \frac{U}{d} \times \sqrt{\frac{\epsilon}{\mu}} \times e^{-jkz}$$

with

$$k = \omega\sqrt{\epsilon\mu},$$

$$Z_c = \frac{E_y}{H_x} = \sqrt{\frac{\epsilon}{\mu}}$$

Propagation coefficient k and wave-impedance η only dependent on material **not** on geometry d .

Are there Other Solutions?

Further solutions under given boundaries: Crossing Waves

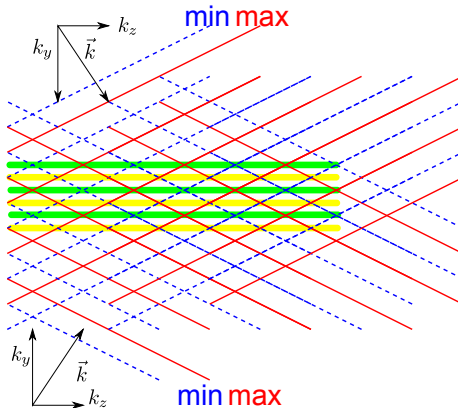

Two plane waves crossing $E_1 = E_0 e^{j(k_x x + k_z z)}$, $E_2 = E_0 e^{j(-k_x x + k_z z)}$ yield interference pattern.

Green-lines: Extremes adding up Yellow-lines: Canceling to zero

PPWG: Other Solutions

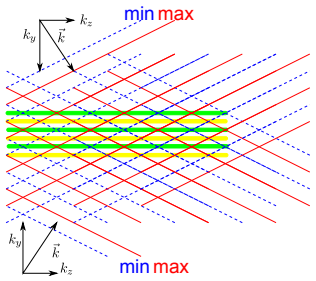

- At canceling regions (yellow) perfectly electric conductors can be placed
- Field is not disturbed (but can practically not being excited anymore)
- Region between conducting planes is Parallel Plate Waveguide!

Mathematics of Parallel Plate Modes

- Fields have vector components \perp to \vec{k} , thus

$$\vec{E}_1 = \begin{pmatrix} 0 \\ E_y \\ E_z \end{pmatrix} = E_0 \begin{pmatrix} 0 \\ \cos \theta \\ \sin \theta \end{pmatrix}, \quad \vec{E}_2 = \begin{pmatrix} 0 \\ E_y \\ E_z \end{pmatrix} = E_0 \begin{pmatrix} 0 \\ \cos \theta \\ -\sin \theta \end{pmatrix},$$

- Angle for propagation is $\sin \theta = k_y/|k|$, $\cos \theta = k_z/|k| = \sqrt{|k|^2 - k_y^2}/|k|^2$
- Total field is thus

$$\begin{aligned} & (\vec{E}_1 \times e^{jk_y y} - \vec{E}_2 \times e^{-jk_y y}) \times e^{jk_z z} = \\ & 2E_0 \begin{pmatrix} 0 \\ j \cos \theta \sin(k_y y) \\ \sin \theta \cos(k_y y) \end{pmatrix} \end{aligned}$$

Observations to PPWG & Crossed Fields

- There is a periodicity in y direction with zero-lines
- Period must be $2 \times d$ (Half-period = d)
 $\Rightarrow k_y d = \pi \Leftrightarrow k_y = \frac{\pi}{d}$
- With

$$k = \frac{2\pi}{\lambda} = \sqrt{k_z^2 + k_y^2}$$

$$\Leftrightarrow k_z = \sqrt{k^2 - k_y^2} = \sqrt{\left(\frac{2\pi}{\lambda}\right)^2 - \left(\frac{\pi}{d}\right)^2}$$

If λ is large (low frequency) k_y eats all of k up and there is nothing remaining for k_z propagation.

- There must be a maximum “allowed” λ .
- This is called **cutoff-wavelength** $\lambda_c = 2d$

Crossed Field Simulation

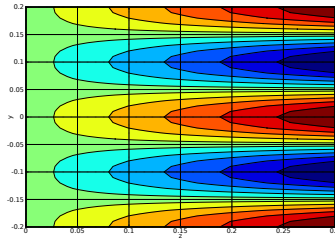

(a) 1.5 GHz

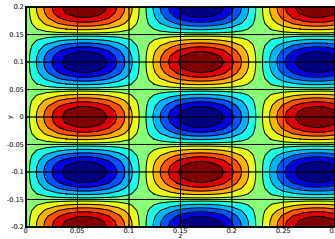

(b) 2 GHz

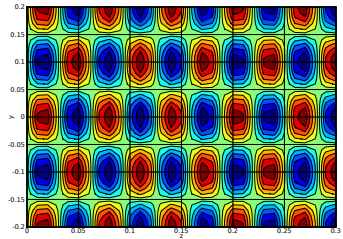

(c) 5 GHz

Crossed Fields with angle optimizes, so that $d = 0.1$ m is OK

- Note, that wavelengths in z -direction changes drastically.
- At Cut-off (wavelength or frequency) $k_z \rightarrow 0$ and wavelength in waveguide $\lambda_g \rightarrow \infty$
- $$\lambda_g = \frac{\lambda_0}{\sqrt{1 - (\lambda_0/\lambda_c)^2}}$$

Parallel Plates: Higher Modes

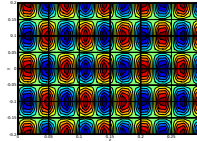

- Virtual PEC-planes can be placed, so that multiple (n) max and zeros are in-between

⇒

$$k_y d = n\pi \Leftrightarrow k_y = \frac{n\pi}{d}$$

$$k_z = \sqrt{\left(\frac{2\pi}{\lambda}\right)^2 - \left(\frac{n\pi}{d}\right)^2}$$

$$\lambda_c = 2\frac{d}{n}$$

PPWG: Higher Modes

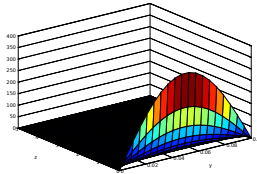

(a) $E_x TE_1$ 1.4 GHz

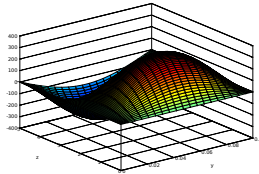

(b) $E_x TE_1$ 1.5 GHz

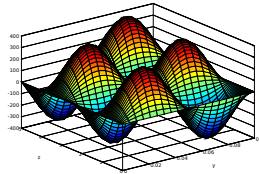

(c) $E_x TE_2$ 3.0 GHz

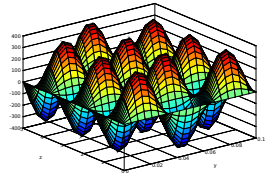

(d) $E_x TE_3$ 4.5 GHz

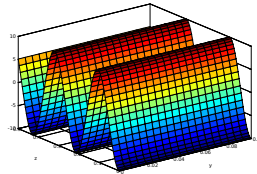

(e) $E_y TEM$ 1.4 GHz

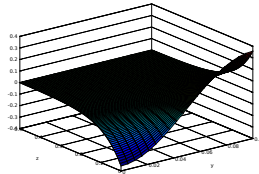

(f) $E_y TM_1$ 1.4 GHz

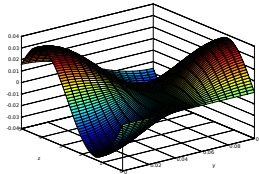

(g) $E_y TM_2$ 1.5 GHz

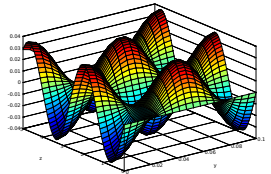

(h) $E_y TM_2$ 3.0 GHz

Modes in Parallel-Plate Waveguide, TE (upper), TEM and TM (lower). Note different z -scaling in (e,f). $d = 1$ m. (a,f) below cutoff.

Propagation Coefficients

- RF Basics
- System Overview
- Fields & Waves
- Transmission Lines
- Practical TL
- Waveguides
 - Planar Waveguides
 - Coupling
 - PCB-Testing
- 2-Port and S-Parameters
- Matching
- Antennas
- Passives
- Transistors

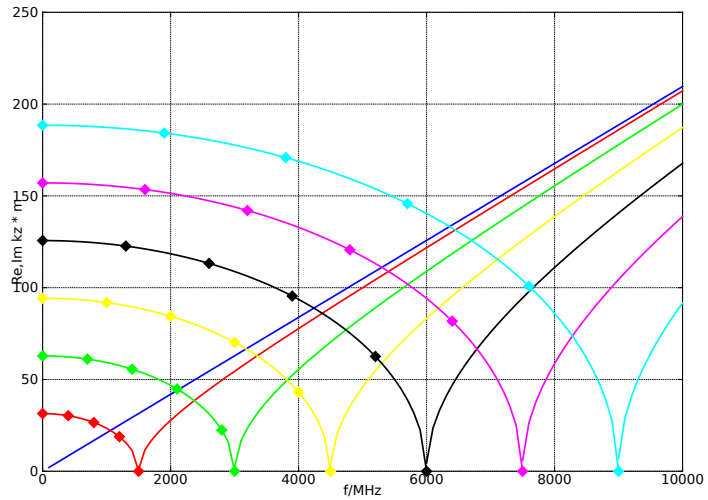

$d = 0.1$ m Waveguide with (increasing) propagation coefficients k_z of increasing order (0,1,2,3,4,5,6). Attenuation coefficient (below cutoff) denoted by diamond.

Propagation Coefficient: Interpretation

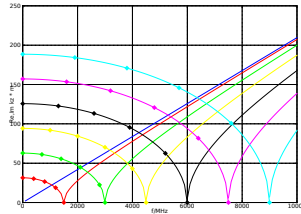

Interpretation:

- $\text{Re} \{k_z\} = 2\pi/\lambda_g$ or wavelength $\lambda_g = 2\pi/\text{Re} \{k_z\}$,
the larger $\text{Re} \{k_z\}$, the shorter the (guided) wave
- Above cut-off phase in radians per meter, or phase velocity $v_p = 2\pi f/\text{Re} \{k_z\}$
- Below cut-off amplitude decay $\propto e^{-\text{Im}\{k_z\}z}$ (How many e per meter)
The larger $\text{Im} \{k_z\}$ the faster the decay of the wave.

Rectangular Waveguide

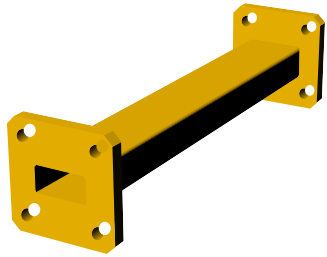

(a)

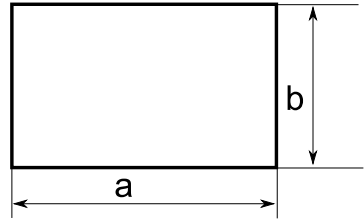

(b)

Waveguide for M-Band with flanges.

- Essentially two Parallel Plate Waveguides in x and y -direction
- Absolutely same argument as above apply

Diff. Eq. Rectangular Waveguide

- For Transverse Electrical Modes (TE):

$$\left(\frac{\partial^2}{\partial x^2} + \frac{\partial^2}{\partial y^2} + k_c^2 \right) h_z(x,y) = 0$$

$$\text{with } h_z(x,y) = X(x) Y(y)$$

$$\frac{\partial^2 X}{\partial x^2} + k_x^2 X = 0$$

$$\frac{\partial^2 Y}{\partial y^2} + k_y^2 Y = 0$$

$$k_x^2 + k_y^2 = k_c^2,$$

$$k_c^2 + k_z^2 = k^2 = \omega^2 \epsilon \mu$$

- For Transverse Magnetic Modes (TM):

$$\left(\frac{\partial^2}{\partial x^2} + \frac{\partial^2}{\partial y^2} + k_c^2 \right) e_z(x,y) = 0$$

Rectangular Waveguide: Solution

- Solution must be such, that tangential electric field at waveguide walls is zero
⇒ field must have \sin -form
- Since two walls: Two different orders (n,m) are present (together with field-forms TE and TM)
- Cut-off frequency

$$f_{c,m,n} = \frac{1}{2\pi\sqrt{\epsilon\mu}} \sqrt{\left(\frac{m\pi}{a}\right)^2 + \left(\frac{n\pi}{b}\right)^2}$$

Example: Ideal Propagation in Waveguide

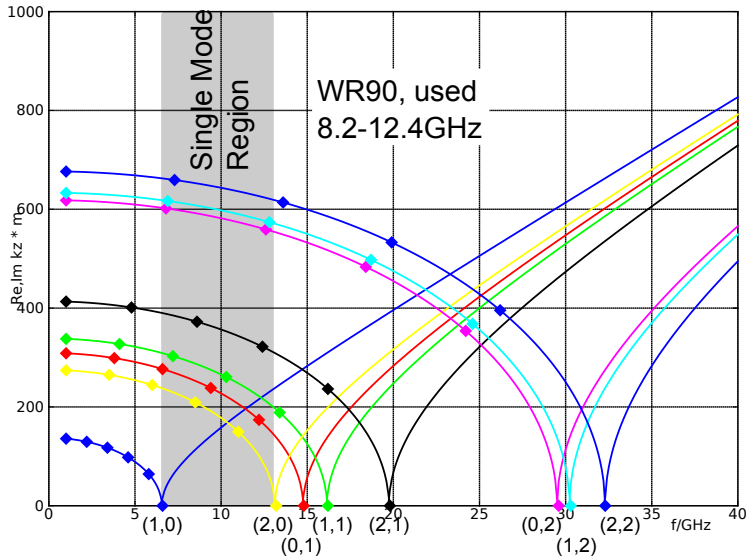

Propagation coefficient for first order modes in WR-90 Waveguide (X-Band). Note: $a/b \neq 2$

Field in R-WG: TE_{10}

- RF Basics
- System Overview
- Fields & Waves
- Transmission Lines
- Practical TL
- Waveguides
 - Planar Waveguides
 - Coupling
 - PCB-Testing
- 2-Port and S-Parameters
- Matching
- Antennas
- Passives
- Transistors

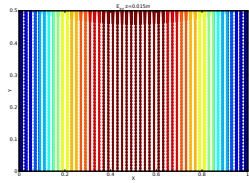

(a) E xy -Cut

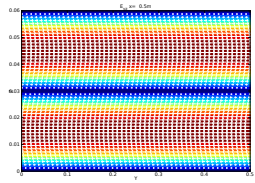

(b) E yz -Cut

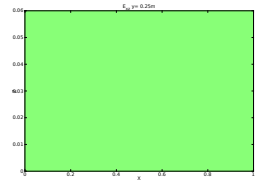

(c) E xz -Cut

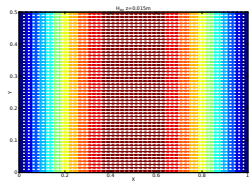

(d) H xy -Cut

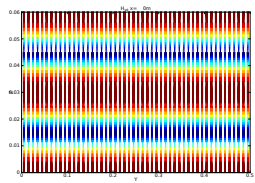

(e) H yz -Cut

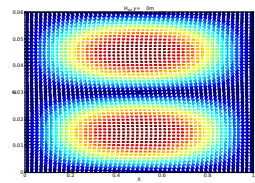

(f) H xz -Cut

Modes in Rectangular Waveguide, different cuts

TE_{10} E-Field (upper), H-Field (lower)



Field in R-WG: TE_{01}

- RF Basics
- System Overview
- Fields & Waves
- Transmission Lines
- Practical TL
- Waveguides
 - Planar Waveguides
 - Coupling
 - PCB-Testing
- 2-Port and S-Parameters
- Matching
- Antennas
- Passives
- Transistors

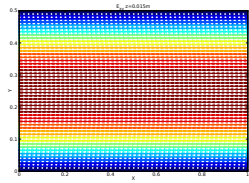

(a) E xy -Cut

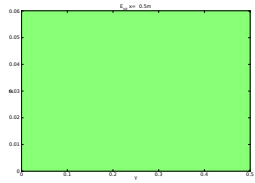

(b) E yz -Cut

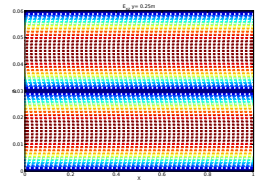

(c) E xz -Cut

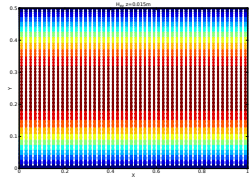

(d) H xy -Cut

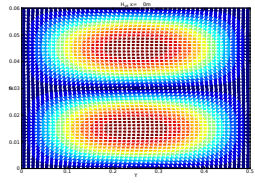

(e) H yz -Cut

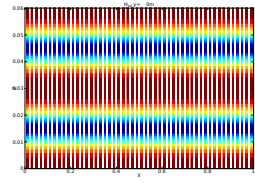

(f) H xz -Cut

Modes in Rectangular Waveguide, different cuts

TE_{01} E-Field (upper), H-Field (lower)



Field in R-WG: TE_{11}

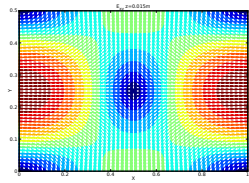

(a) E xy -Cut

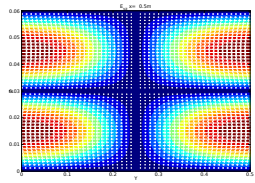

(b) E yz -Cut

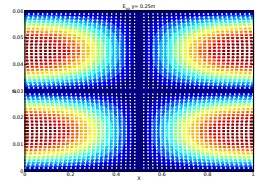

(c) E xz -Cut

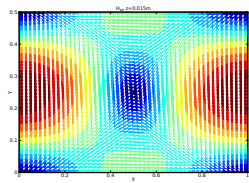

(d) H xy -Cut

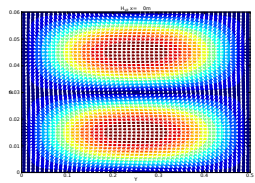

(e) H yz -Cut

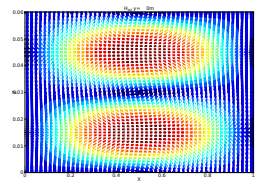

(f) H xz -Cut

Modes in Rectangular Waveguide, different cuts

TE_{11} E-Field (upper), H-Field (lower)

Field in R-WG: TM_{11}

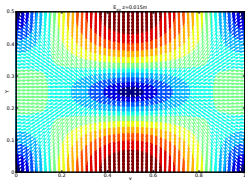

(a) E xy -Cut

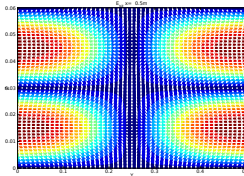

(b) E yz -Cut

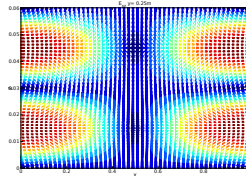

(c) E xz -Cut

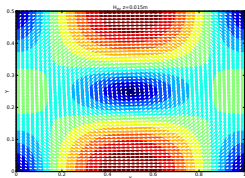

(d) H xy -Cut

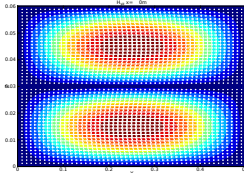

(e) H yz -Cut

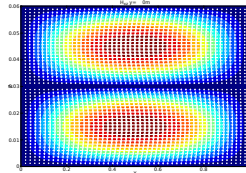

(f) H xz -Cut

Modes in Rectangular Waveguide, different cuts

TM_{11} E-Field (upper), H-Field (lower)

Field in R-WG: TE_{20}

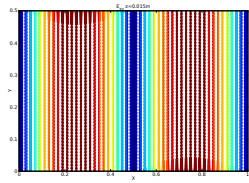

(a) E xy -Cut

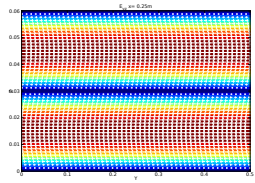

(b) E yz -Cut

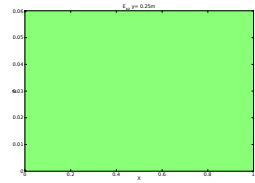

(c) E xz -Cut

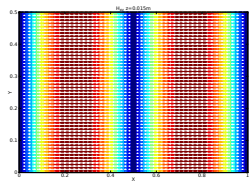

(d) H xy -Cut

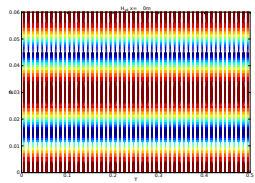

(e) H yz -Cut

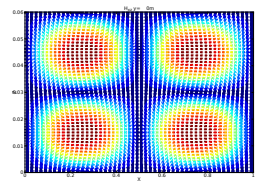

(f) H xz -Cut

Modes in Rectangular Waveguide, different cuts

TE_{20} E-Field (upper), H-Field (lower)

Field in R-WG: TE_{21}

- RF Basics
- System Overview
- Fields & Waves
- Transmission Lines
- Practical TL
- Waveguides
 - Planar Waveguides
 - Coupling
 - PCB-Testing
- 2-Port and S-Parameters
- Matching
- Antennas
- Passives
- Transistors

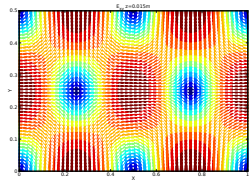

(a) E xy -Cut

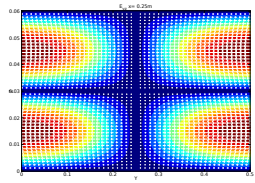

(b) E yz -Cut

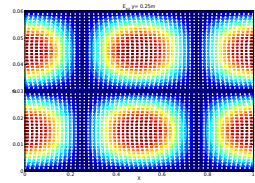

(c) E xz -Cut

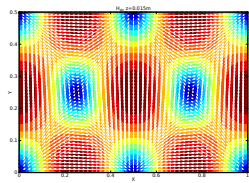

(d) H xy -Cut

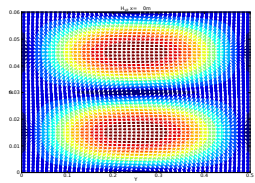

(e) H yz -Cut

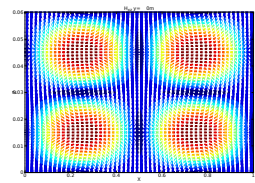

(f) H xz -Cut

Modes in Rectangular Waveguide, different cuts

TE_{21} E-Field (upper), H-Field (lower)



Field in R-WG: TM_{21}

- RF Basics
- System Overview
- Fields & Waves
- Transmission Lines
- Practical TL
- Waveguides
 - Planar Waveguides
 - Coupling
 - PCB-Testing
- 2-Port and S-Parameters
- Matching
- Antennas
- Passives
- Transistors

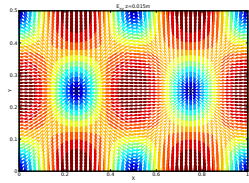

(a) E xy -Cut

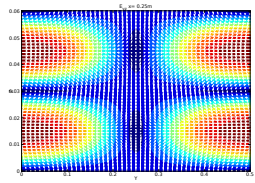

(b) E yz -Cut

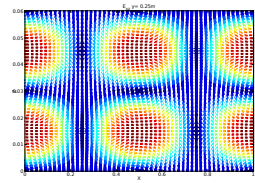

(c) E xz -Cut

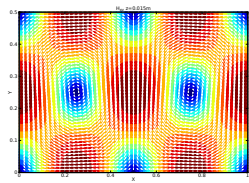

(d) H xy -Cut

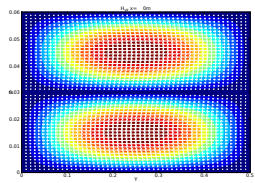

(e) H yz -Cut

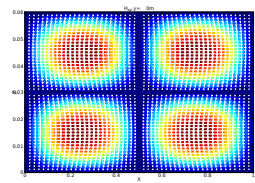

(f) H xz -Cut

Modes in Rectangular Waveguide, different cuts

TM_{21} E-Field (upper), H-Field (lower)



Field in R-WG: TE_{02}

- RF Basics
- System Overview
- Fields & Waves
- Transmission Lines
- Practical TL
- Waveguides
 - Planar Waveguides
 - Coupling
 - PCB-Testing
- 2-Port and S-Parameters
- Matching
- Antennas
- Passives
- Transistors

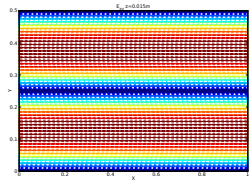

(a) E xy -Cut

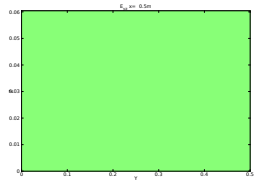

(b) E yz -Cut

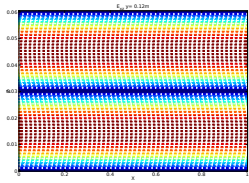

(c) E xz -Cut

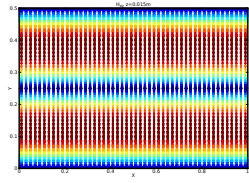

(d) H xy -Cut

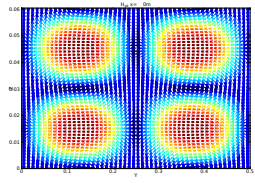

(e) H yz -Cut

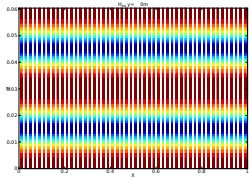

(f) H xz -Cut

Modes in Rectangular Waveguide, different cuts

TE_{02} E-Field (upper), H-Field (lower)

Field in R-WG: TE_{12}

- RF Basics
- System Overview
- Fields & Waves
- Transmission Lines
- Practical TL
- Waveguides
 - Planar Waveguides
 - Coupling
 - PCB-Testing
- 2-Port and S-Parameters
- Matching
- Antennas
- Passives
- Transistors

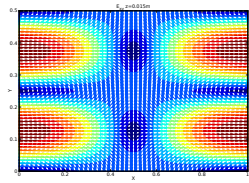

(a) E xy -Cut

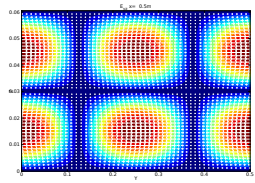

(b) E yz -Cut

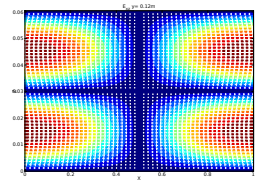

(c) E xz -Cut

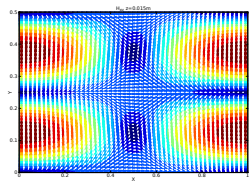

(d) H xy -Cut

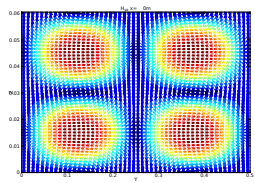

(e) H yz -Cut

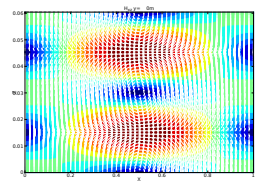

(f) H xz -Cut

Modes in Rectangular Waveguide, different cuts

TE_{12} E-Field (upper), H-Field (lower)



Field in R-WG: TM_{12}

- RF Basics
- System Overview
- Fields & Waves
- Transmission Lines
- Practical TL
- Waveguides
 - Planar Waveguides
 - Coupling
 - PCB-Testing
- 2-Port and S-Parameters
- Matching
- Antennas
- Passives
- Transistors

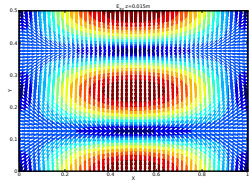

(a) E xy -Cut

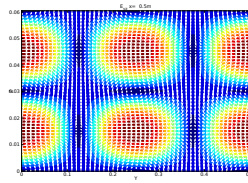

(b) E yz -Cut

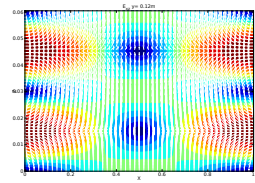

(c) E xz -Cut

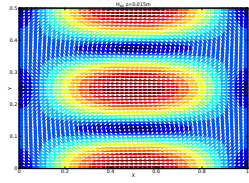

(d) H xy -Cut

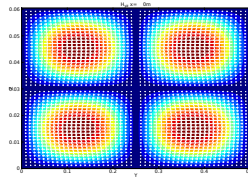

(e) H yz -Cut

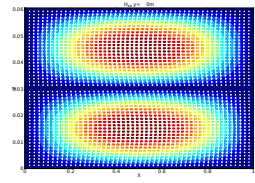

(f) H xz -Cut

Modes in Rectangular Waveguide, different cuts

TM_{12} E-Field (upper), H-Field (lower)



Field in R-WG: TE_{22}

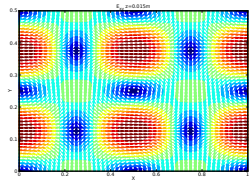

(a) E xy -Cut

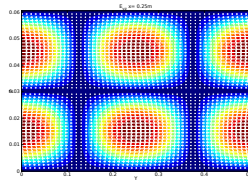

(b) E yz -Cut

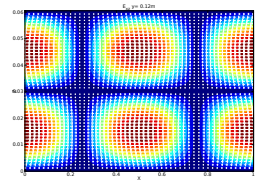

(c) E xz -Cut

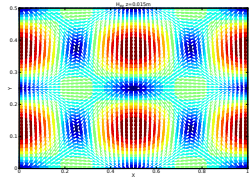

(d) H xy -Cut

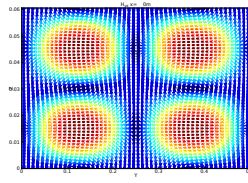

(e) H yz -Cut

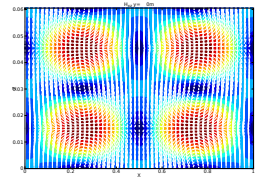

(f) H xz -Cut

Modes in Rectangular Waveguide, different cuts

TE_{22} E-Field (upper), H-Field (lower)

Field in R-WG: TM_{22}

- RF Basics
- System Overview
- Fields & Waves
- Transmission Lines
- Practical TL
- Waveguides
 - Planar Waveguides
 - Coupling
 - PCB-Testing
- 2-Port and S-Parameters
- Matching
- Antennas
- Passives
- Transistors

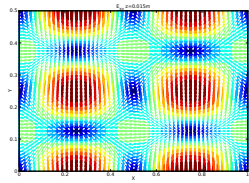

(a) E xy -Cut

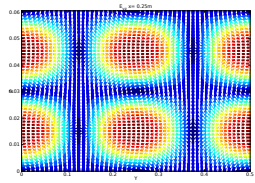

(b) E yz -Cut

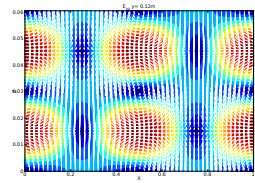

(c) E xz -Cut

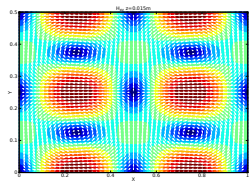

(d) H xy -Cut

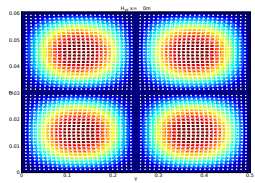

(e) H yz -Cut

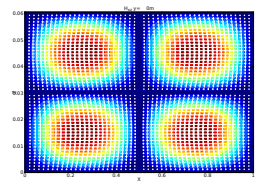

(f) H xz -Cut

Modes in Rectangular Waveguide, different cuts

TM_{22} E-Field (upper), H-Field (lower)



Rectangular Waveguides TE_{10} Summary

Rectangular Waveguide

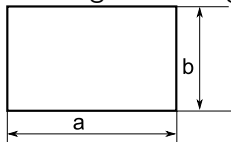

Cutoff-Frequency (fundamental mode)

$$f_c = \frac{1}{2\sqrt{\epsilon_0\mu_0}a}, \quad \lambda_c = 2a$$

Field-Impedance

$$Z_c = Z_0 / \sqrt{1 - (\lambda_0/\lambda_c)^2}$$

Effective Wavelength in the guide

$$\lambda_{eff} = \lambda_0 / \sqrt{1 - (\lambda_0/\lambda_c)^2}$$

The characteristic impedance is not uniquely defined because of transversal field components

Modes

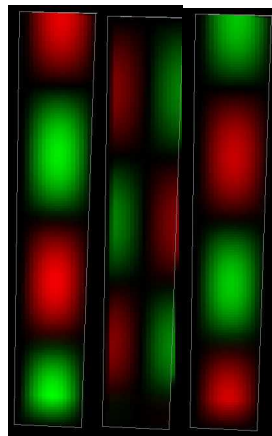

(a) (b) (c)
TE₀₁ Mode with (a) E_y (b) H_z (c) H_x

Rectangular Waveguides II

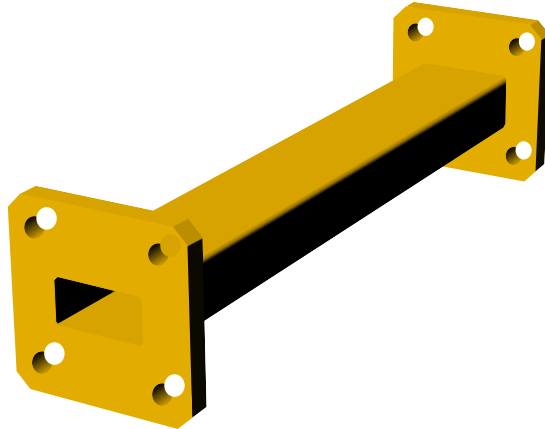

Waveguide for M-Band with flanges.

Rectangular Waveguides III

Frequency/GHz	Band	DIN 47302	IEC 153 EIA	Width a /mm	Width a /Inch	a/b
1.12...1.7	L	R 14	WR 650	165.10	6.500	2.00
1.7...2.6	LA	R 22	WR 430	109.22	4.300	2.00
2.2...3.3	LS	R 26	WR 340	86.36	3.400	2.00
2.6...3.95	S	R 32	WR 284	72.14	2.840	2.12
3.22...4.90	A	R 40	WR 229	58.17	2.290	2.00
3.95...5.85	G	R 48	WR 187	47.55	1.872	2.15
4.64...7.05	C	R 58	WR 159	40.39	1.590	2.00
5.85...8.2	J	R 70	WR 137	34.85	1.372	2.21
7.05...10.0	H	R 84	WR 112	28.50	1.122	2.00
8.2...12.4	X	R 100	WR 90	22.86	0.900	2.25
10.0...15.0	M	R 120	WR 75	19.05	0.750	2.00
12.4...18.0	P	R 140	WR 62	15.80	0.622	2.00
15.0...22.0	N	R 180	WR 51	12.95	0.510	2.00
18.0...26.5	K	R 220	WR 42	10.67	0.420	2.47
21.7...23.0	R	260	WR 34	8.64	0.340	2.00
25.5...40.0	R	R 320	WR 28	7.11	0.280	2.00
33.0...50.0	Q		WR 22	5.69	0.224	2.00
40.0...60.0	U		WR 19	4.78	0.188	2.00
50.0...75.0	V		WR 15	3.76	0.148	2.00
75.0...110	W		WR 10	2.54	0.100	2.00

Insert: Velocities

- How fast is the wave (zero or maximum)? \Rightarrow **Phase velocity** v_p
- How fast is a group of waves? \Rightarrow **Group velocity** v_g
(comes close to speed of the signal)
- How fast is really the signal?

Phase-Velocity

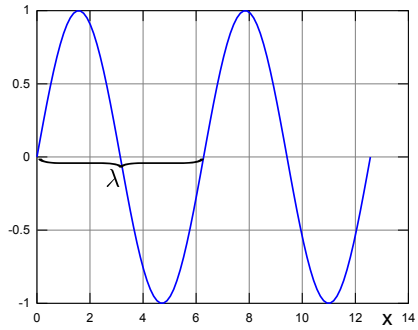

- During one period of length T one entire wave of length λ (wavelength in medium or guide) has passed the point of observation

$$\Rightarrow v_p = \frac{\lambda}{T} = \frac{2\pi}{2\pi} \times \frac{\frac{1}{T}}{\frac{1}{\lambda}} = \frac{\omega}{k_z}$$

Phase-Velocity II

- Generally $y = \sin(\omega_1 t - k_z z)$ phase stationary if observer moves with $v_p = \omega/k_z$
- In Rectangular waveguide

$$\begin{aligned}
 v_p &= \frac{\omega}{\sqrt{\omega^2 \epsilon \mu - \left(\frac{m\pi}{a}\right)^2 - \left(\frac{n\pi}{b}\right)^2}} \\
 &= \frac{1}{\sqrt{\epsilon \mu - \left(\frac{m\pi}{\omega a}\right)^2 - \left(\frac{n\pi}{\omega b}\right)^2}} \\
 &= \frac{c}{\sqrt{1 - \left(\frac{k_c}{k_0}\right)^2}}
 \end{aligned}$$

$$\omega \rightarrow \infty \Rightarrow v_p \rightarrow c$$

$$\omega \rightarrow \omega_c \Rightarrow v_p \rightarrow \infty$$

Group-Velocity

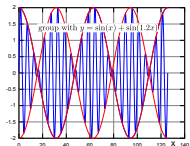

- Start wave-packet with

$$\begin{aligned}
 y &= \sin(\omega_1 t - k_{z1} z) + \sin(\omega_2 t - k_{z2} z) \\
 &= 2 \cos\left(\frac{(\omega_1 + \omega_2)t - (k_{z1} + k_{z2})z}{2}\right) \cos\left(\frac{(\omega_2 - \omega_1)t - (k_{z2} - k_{z1})z}{2}\right)
 \end{aligned}$$

- Again, **packet** stationary if observer moves with

$$\begin{aligned}
 v_g &= \frac{\omega_2 - \omega_1}{k_{z2} - k_{z1}} \\
 \lim_{\omega_2 \rightarrow \omega_1} v_g &= \frac{d\omega}{dk_z}
 \end{aligned}$$

- Rectangular waveguide

$$\omega = \sqrt{\frac{k_z^2 - \left(\frac{m\pi}{\omega a}\right)^2 - \left(\frac{n\pi}{\omega b}\right)^2}{\epsilon\mu}}$$

$$v_g = \frac{d\omega}{dk_z} = \frac{k_z}{\sqrt{k_z^2 - \left(\frac{m\pi}{\omega a}\right)^2 - \left(\frac{n\pi}{\omega b}\right)^2}} \frac{1}{\sqrt{\epsilon\mu}}$$

$$= c \sqrt{1 - \left(\frac{m\pi}{\omega a}\right)^2 \frac{1}{\epsilon\mu} - \left(\frac{n\pi}{\omega b}\right)^2 \frac{1}{\epsilon\mu}}$$

$$= c \sqrt{1 - \left(\frac{k_c}{k_0}\right)^2} = \frac{c^2}{v_p}$$

$$\omega \rightarrow \infty \Rightarrow v_g \rightarrow c$$

$$\omega \rightarrow \omega_c \Rightarrow v_g \rightarrow 0$$

Velocities

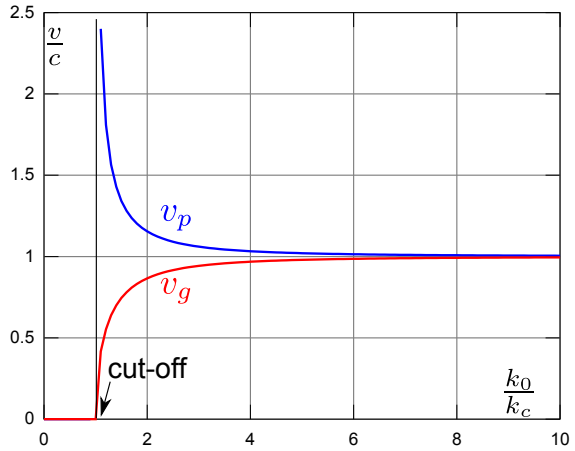

Phase (blue) and group (red) velocity for one mode in rectangular or parallel plate waveguide.

How to Interpret Velocities?

- If $f \rightarrow \infty$ “ray” of microwaves “shoots” right through the waveguide (like laser-light). Speed approaches c
- If $f = f_c$ wave in guide is ∞ -long, phase travels ∞ fast
- If $f = f_c$ wave bounces left and right between walls, all k is eaten up by k_x , no propagation in z -direction, signal ∞ slow.

R-WG Iris in E-Plane

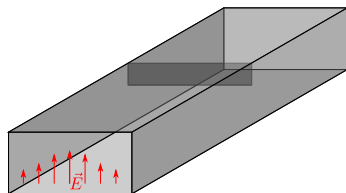

(a)

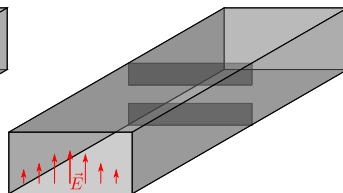

(b)

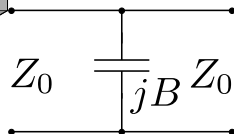

(c)

Iris (of zero thickness) in E-Plane = (frequency dependent) shunt cap [2, pp. 217].

R-WG Step in E-Plane

- RF Basics
- System Overview
- Fields & Waves
- Transmission Lines
- Practical TL
- Waveguides
- Planar Waveguides
- Coupling
- PCB-Testing
- 2-Port and S-Parameters
- Matching
- Antennas
- Passives
- Transistors

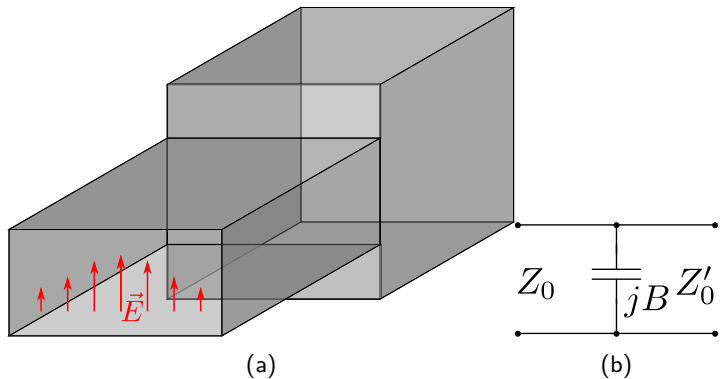

Step in height (E-Plane) = (frequency dependent) shunt cap [2, pp. 217] with impedance step.

R-WG Iris in H-Plane

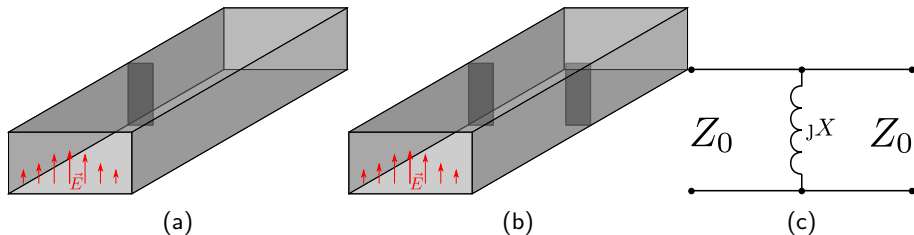

Iris (of zero thickness) in H-Plane = (frequency dependent) shunt inductor [2, pp. 217].

R-WG Step in H-Plane

- RF Basics
- System Overview
- Fields & Waves
- Transmission Lines
- Practical TL
- Waveguides
 - Planar Waveguides
 - Coupling
 - PCB-Testing
- 2-Port and S-Parameters
- Matching
- Antennas
- Passives
- Transistors

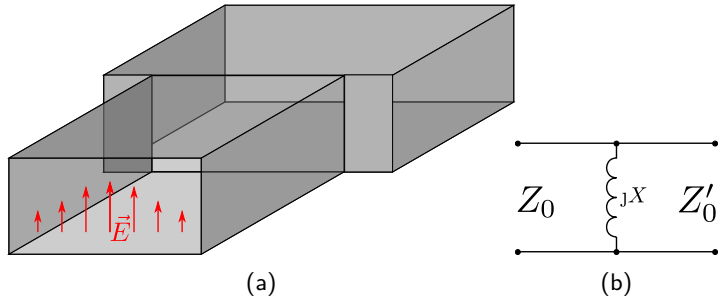

Step in width (H-Plane) = (frequency dependent) shunt inductor [2, pp. 217] with impedance step.

Circular Waveguide

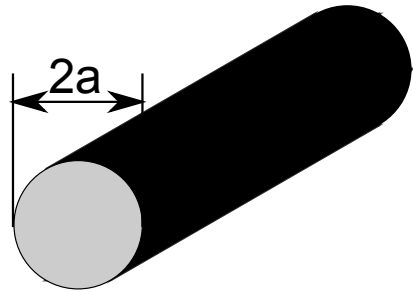

Use water pipe as waveguide

- Basically the same mechanism as for rectangular waveguide
- Different mathematics (cylindrical coordinates) [4]
- Again, TE and TM-modes with **radial and angular** order

Diff Eq. for Circular Waveguide

- General wave-equation in cylindrical coordinates [4]

$$\left(\frac{\partial^2}{\partial \rho^2} + \frac{1}{\rho} \frac{\partial}{\partial \rho} + \frac{1}{\rho^2} \frac{\partial^2}{\partial \phi^2} + k_c^2 \right) \left\{ \begin{pmatrix} h_z(\rho, \phi) \\ e_z(\rho, \phi) \end{pmatrix} \right\} = 0$$

- Separation of variables e.g. $e_z = R(\rho)\Phi(\phi)$
- Solution

$$\left\{ \begin{pmatrix} h_z(\rho, \phi) \\ e_z(\rho, \phi) \end{pmatrix} \right\} = (A \sin(n\phi) + B \cos(n\phi)) (C J_n(k_c \rho) + D Y_n(k_c \rho))$$

$$\rightarrow B' \cos(n\phi) J_n(k_c \rho)$$

polarization selected through \cos

and Y_n (Bessel function of second kind) impossible because of singularity at 0.

First Modes in CWG

- Analysis of solution of characteristic equations

$$J_n k_c a = 0$$

$$J'_n(k_c a) = 0$$

shows:

- lowest order modes are

Nr.	Mode	$\{k_c a\}_{nm}$	Nr.	Mode	$\{k_c a\}_{nm}$
1	TE_{11}	1.8412	3	TE_{21}	3.0542
2	TM_{01}	2.4048	4	$TE_{01} = TM_{11}$	3.8317

Field in C-WG: TE_{11} & TM_{01}

- RF Basics
- System Overview
- Fields & Waves
- Transmission Lines
- Practical TL
- Waveguides
 - Planar Waveguides
 - Coupling
 - PCB-Testing
- 2-Port and S-Parameters
- Matching
- Antennas
- Passives
- Transistors

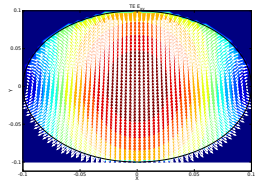

(a) TE_{11} E xy -Cut

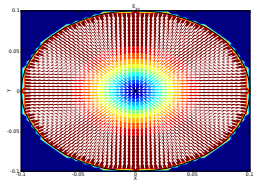

(b) TM_{01} E xy -Cut

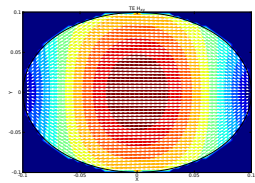

(c) TE_{11} H xy -Cut

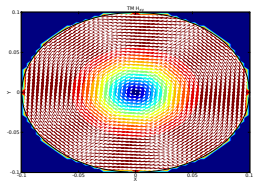

(d) TM_{01} H xy -Cut

Modes in Circular Waveguide, transverse cut TE_{11} (left) and TM_{01} (right)

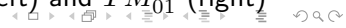

Field in C-WG: TE_{21} & TE_{01}

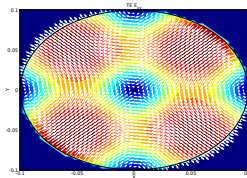

(a) TE_{21} E xy -Cut

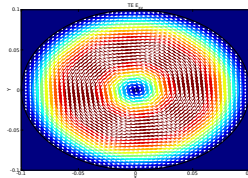

(b) TE_{01} E xy -Cut

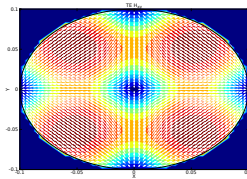

(c) TE_{21} H xy -Cut

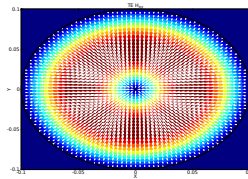

(d) TE_{01} H xy -Cut

Modes in Circular Waveguide, transverse cut TE_{21} (left) and TE_{01} (right)

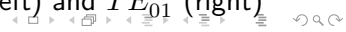

Field in C-WG: TM_{11} & TE_{45}

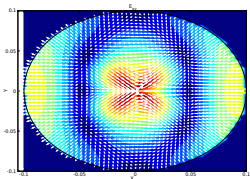

(a) TM_{11} E xy -Cut

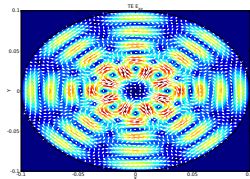

(b) TE_{45} E xy -Cut

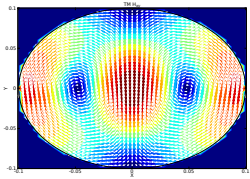

(c) TM_{21} H xy -Cut

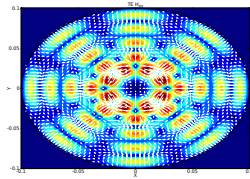

(d) TE_{45} H xy -Cut

Modes in Circular Waveguide, transverse cut TM_{11} (left) and TE_{45} (right) as example for really high order mode

Everyday Application of Circular Waveguide

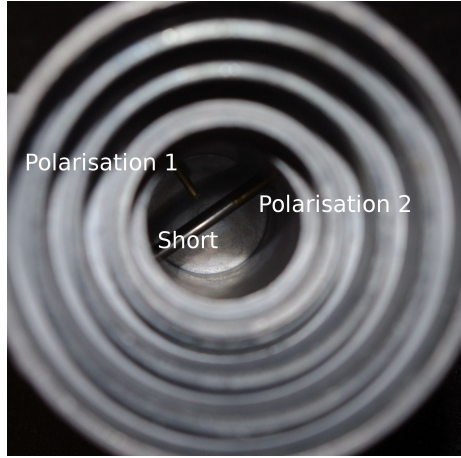

LNA Satellite-TV front end with circular waveguide and field-probes for both orthogonal polarizations

Coaxial Waveguide

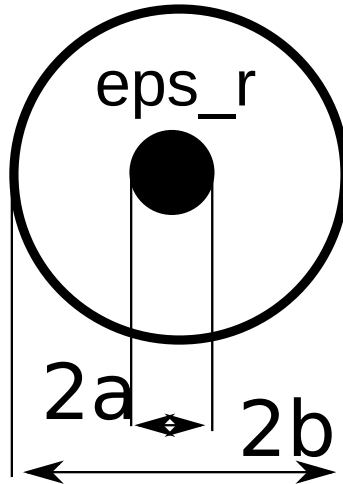

- Supports TEM wave, because of two isolated conductors
- If frequency gets higher, supports TE and TM modes, similar to the circular waveguide

Coax: TEM-Mode

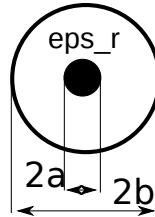

- Solution for potential of Laplace's Equation $\Delta U = 0$
- Propagation independent of geometry, Wave impedance as given

$$\epsilon_{eff} = \epsilon_r, \quad k_z = k$$

$$Z_c = Z_0 \ln(b/a) / (2\pi\sqrt{\epsilon_r})$$

free space impedance

$$Z_0 = \sqrt{\frac{L'}{C'}} = \sqrt{\frac{\mu_0}{\epsilon_0}} = 120\pi \Omega$$

Higher order Mode in Coax-Line

- Undesired: Higher order mode propagating in Coax.
- Differential Equation same as for circular waveguide
- Already know: TE_{11} should be first mode to propagate
- Cut-off of this mode can be approximated as [3]

$$k_c = \frac{2\pi}{\lambda_c} = \frac{2\pi f_c}{\sqrt{\epsilon\mu}} \approx \frac{2}{a+b}$$

Coax-Line: Fields

- RF Basics
- System Overview
- Fields & Waves
- Transmission Lines
- Practical TL
- Waveguides
 - Planar Waveguides
 - Coupling
 - PCB-Testing
- 2-Port and S-Parameters
- Matching
- Antennas
- Passives
- Transistors

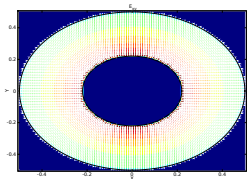

(a) TEM E xy -Cut

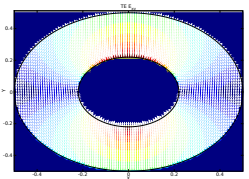

(b) TE_{01} E xy -Cut

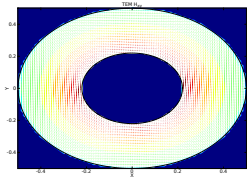

(c) TEM H xy -Cut

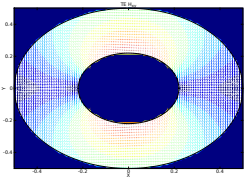

(d) TE_{01} H xy -Cut

Modes in Coaxial Waveguide (50Ω) at 5 GHz with $a = 220$ mm, $b = 500$ mm

TEM (left) and TE_{11} (right)



Excitation of Higher Order Mode

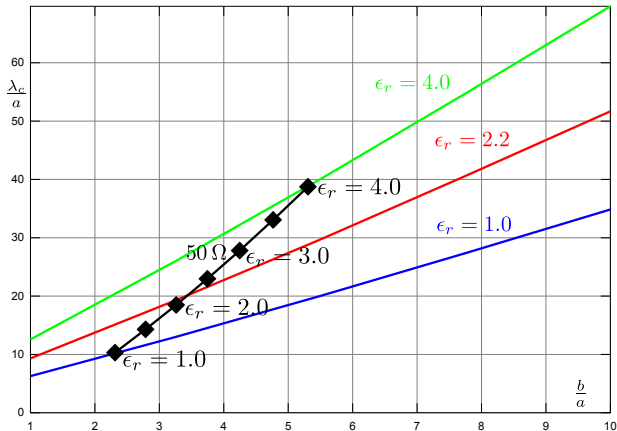

Normalized cutoff-wavelength for TE_{11} mode for normalized radii

Excitation of Higher Order Mode

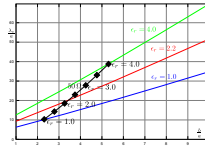

Examples

- RG-58 cable (inner radius 0.4 mm, $\epsilon_r \approx 2.2$) $\rightarrow b/a \approx 3.4$
 $\Rightarrow \lambda_c/a = 20 \Rightarrow \lambda_c \approx 8 \text{ mm} \Rightarrow f_c \approx 37.5 \text{ GHz}$
- Ecoflex-10-Cable with inner diameter $d_i = 2.85 \text{ mm}$ and $\epsilon_r = 1.35$
 $\Rightarrow f_c \approx 16 \text{ GHz}$

Coaxial Connectors

Connector summary Connector type	Frequency range	Mates with	Avoid mating with	torq. N cm
7 mm APC7	18 GHz			136 (Finger)
N	18 GHz			136 (Finger)
SMA	variable, 18 to 24 GHz	3.5, 2.92 mm	2.4 mm	56
3.5 mm (APC 3.5)	34 GHz	SMA, 2.92 mm	2.4 mm	90
2.92 mm or "K"	To 40 GHz	SMA, 3.5 mm	2.4 mm	90
2.4 mm	≥ 50 GHz	1.85 mm only	SMA, 2.92, 3.5 mm	
1.85 mm	65 to 70 GHz	2.4 mm only		
1 mm	110 GHz			
MM(B,C,P)X	12.4, 6, 65 GHz			Snap on
SMB(FAKRA)	4 GHz			Snap on
MCX	6 GHz			Snap on
BNC	4 GHz			Bajonett
U.FL	6 GHz	UMCC, IPX, MHF etc.		Snap on

Planar Waveguides

- 5 Practical TL
 - Waveguides
 - Planar Waveguides
 - Coupling
 - PCB-Testing

- 6 2-Port and S-Parameters

- RF Basics
- System Overview
- Fields & Waves
- Transmission Lines
- Practical TL
 - Waveguides
 - Planar Waveguides**
 - Coupling
 - PCB-Testing
- 2-Port and S-Parameters
- Matching
- Antennas
- Passives
- Transistors

Coplanar Waveguide

Coplanar Line (grounded and non-grounded)

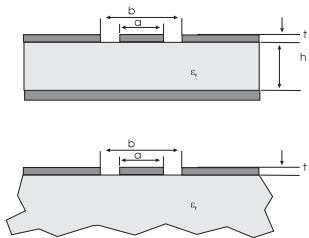

- Coupled slot-line: Odd (fundamental) mode is of interest
- All on one plane, easy connect for semiconductors
- Short-circuit easy to realize, no via required

Micro-Strip-Line

Geometry

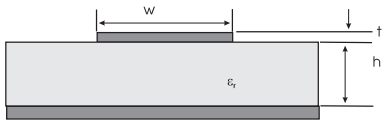

Impedance and effective permittivity

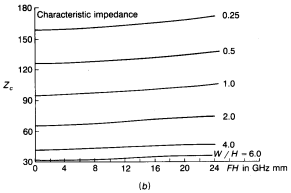
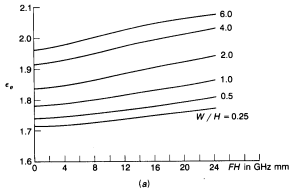

(Collin p.158 [1], $\epsilon_r = 2.26$)

Micro-Strip: Current Distribution

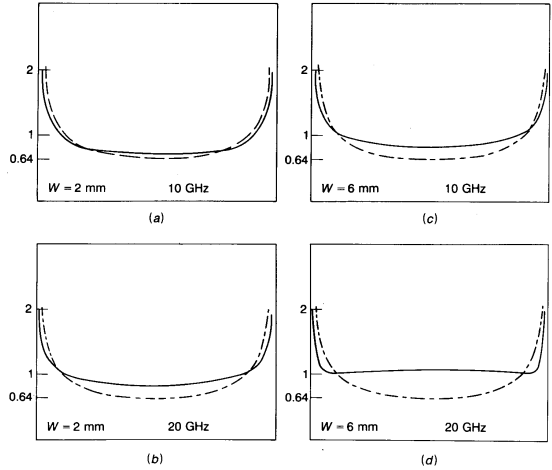

(Collin p.164 [1], broken-line: quasi static current distribution, Alumina substrate H=1mm)

Micro-Strip Line: Some Remarks

- Relatively easy to handle in PCB
- OPEN is OK, but not perfect (to be seen later)
- SHORT only manufacture-able with via (not ideal, either)
- BENDS/ CURVES should be mitered
- (Quasi-static) Effective design formulas exist, also for buried or multi-layered micro-strip lines
- Watch out for
 - Disturbances in Ground plane
 - Coupling to other lines
 - Disturbances (e.g. shielding cages) in vicinity of the line!
 - substrate may be an-isotropic, i.e. ϵ_r differs with direction.

Calculation of Effective Properties of MS

Effective dielectric constant:

$$\epsilon_{eff} = \frac{\epsilon_r + 1}{2} + \frac{\epsilon_r - 1}{2} \sqrt{1 + \frac{12H}{W}}^{-1} + F(\epsilon_r, H) - 0.217(\epsilon_r - 1) \frac{T}{\sqrt{WH}}$$

with

$$F(\epsilon_r, H) = \begin{cases} 0.02(\epsilon_r - 1)(1 - W/H)^2, & \text{for } W/H < 1 \\ 0 & \text{for } W/H > 1 \end{cases}$$

Die characteristic impedance is

$$Z_c = \sqrt{\frac{\epsilon_0 \mu_0}{\epsilon_{eff}}} \frac{1}{C_a}$$

with

$$C_a = \begin{cases} \frac{2\pi\epsilon_0}{\ln(8H/W + 4W/H)} & W/H \leq 1 \\ \epsilon_0 [W/H + 1.393 + 0.667 \ln(W/H + 1.444)] & W/H > 1 \end{cases}$$

Micro-Strip: OPEN



- Micro-strip open end is effectively described by length extension or
- Effective capacitance at end of the line
- The wider the strip, the longer the effective extension

Micro-Strip: The RADIAL STUB

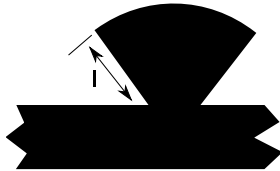

Radial Stub

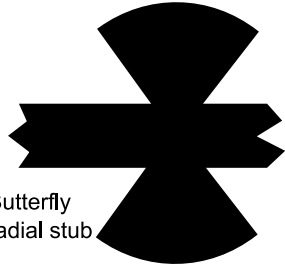

Butterfly
radial stub

- Effectively used like Open micro-strip line stub
- Higher capacitance than line
- Better defined location at line

Micro-Strip: SHORT/ VIA

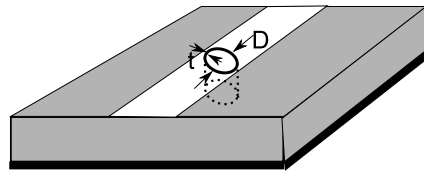

MS via of diameter D and thickness t

- Micro-strip via is described by series resistance and inductor to ground
- Series resistance: Depends on DC res. of structure (i.e. specific resistance of material) and on skin-effect (current only at outer boundary of via)
- Inductance is dominant

Micro-Strip: BENDS

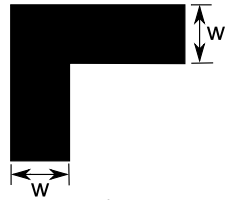

90° bend

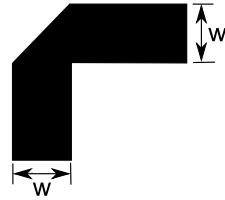

50% mitered bend

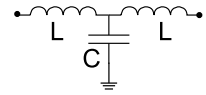

T equivalent circuit

- Micro-strip bend should be conducted as mitered bends
- Miter acts as “Mirror” so that the wave “sees” the line going on straight
- Equivalent circuit is a T-diagram with L and C

Micro-Strip: Slot in Ground Plane

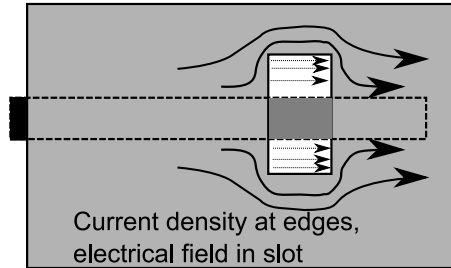

Shown is a slot in the ground plane beneath a micro-strip line.

- (Back)-Current flows around the edges of the slot, thus leading to higher current densities at the edges
- Consequently potential differences results, leading to electrical field
- This leads to higher loss and (field) especially to irradiation
- We have build a very effective antenna! Was this what we wanted?

- RF Basics
- System Overview
- Fields & Waves
- Transmission Lines
- Practical TL
 - Waveguides
 - Planar Waveguides
 - Coupling**
 - PCB-Testing
- 2-Port and S-Parameters
- Matching
- Antennas
- Passives
- Transistors

- 5 Practical TL
 - Waveguides
 - Planar Waveguides
 - **Coupling**
 - PCB-Testing
- 6 2-Port and S-Parameters

Micro-Strip: COUPLED LINES

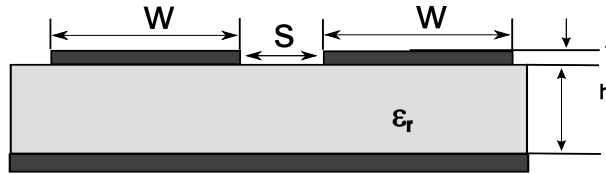

- Supports two modes: Even and Odd thus supports two different impedances: Z_o, Z_e .
- Coupling between lines $C = \frac{Z_e - Z_o}{Z_e + Z_o}$
- Characteristic impedance of line-system is geometric mean of even and odd mode $Z_0 = \sqrt{Z_e Z_o}$
- Usage in coupler structures!
- Unwanted parasitics: Two micro-strip lines in parallel are couplers, thus: Do not get too close

Micro-Strip: Coupled Lines

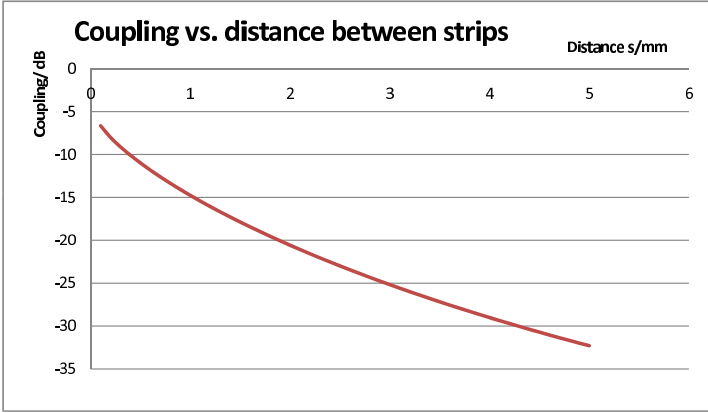

Micro-strip couples lines ($w = 1\text{mm}$, $h = 1\text{mm}$, $\epsilon_r = 9.7$)

Coupling for even $2w$ spacing between the lines is still significant!

Stripline

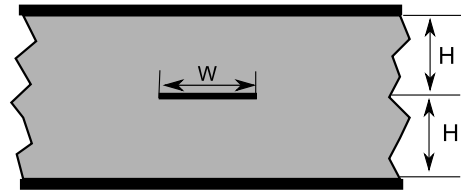

- Shielded to both: top and bottom
- Can be almost fully shielded when vias are used at sides
- Electrical field better confined due to higher effective permittivity ($\epsilon_{eff} = \epsilon_r$), low dispersion
- Requires at least three layers

Stripline: Coupled

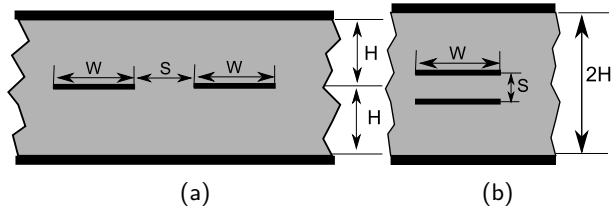

Coplanar (a) and broadside (b) coupled striplines

- Coplanar: All in one layer
- Broadside: Lines in different layers

Coupling of Practical Lines

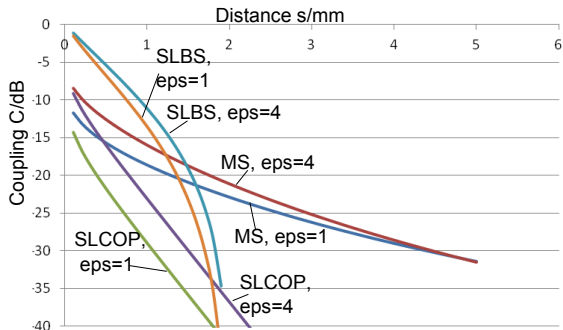

Micro-strip line has highest coupling, Coplanar coupled stripline best de-coupling

Parameters: $h = 1 \text{ mm}$, $Z_0 = 50 \Omega$ for (centered) strip, \Rightarrow

Name	Short	$(w/mm, \epsilon_r = 1)$	$(w/mm, \epsilon_r = 4)$
Strip, broadside	SLBS	2.9	1.0
Strip, coplanar	SLCOP	2.9	1.0
Micro-strip	MS	5.0	2.1

RF Basics

System
Overview

Fields &
Waves

Transmission
Lines

Practical TL

Waveguides

Planar Waveguides

Coupling

PCB-Testing

2-Port and
S-Parameters

Matching

Antennas

Passives

Transistors

5 Practical TL

- Waveguides
- Planar Waveguides
- Coupling
- **PCB-Testing**

6 2-Port and S-Parameters

References

- RF Basics
- System Overview
- Fields & Waves
- Transmission Lines
- Practical TL
 - Waveguides
 - Planar Waveguides
 - Coupling
- PCB-Testing
- 2-Port and S-Parameters
- Matching
- Antennas
- Passives
- Transistors



R. E. Collin. *Foundations for Microwave Engineering*. 2. Aufl. McGraw Hill, 1991.



Nathan Marcuwitz. *Waveguide Handbook*. Available online under <http://bunkerofdoom.com/lit/mitser/index.html> (17.8.2012). McGraw Hill, 1951.



D. M. Pozar und D. H. Schaubert. *Microstrip Antennas: The Analysis and Design of Microstrip Antennas and Arrays*. IEEE Press, 1995.



David M. Pozar. *Microwave Engineering*. 3. Aufl. New York: John Wiley and Sons, 2005.

2-Port and S-Parameters

- 4 Transmission Lines
- 5 Practical TL
- 6 2-Port and S-Parameters**
- 7 Matching
- 8 Antennas
- 9 Passive Components and Filters

What to Watch Out For

You should learn

- Why RF-Engineers refrain from using Z , and Y - Parameters
- What they use instead and why this is useful
- Where these parameters can be used (linear circuits)
- How these parameters (ideally) can be measured
- How all these parameters inter-relate
- And how this fits into the picture of travelling wave and transmission lines

The Problem

RF-engineering is considered a bit more difficult than “normal” electrical engineering. Some of that is because

- Measuring of (and thinking in) conventional conductance and resistance-parameters is difficult (even though theoretically all these things are valid, if only you have infinite precision)
- We do not have infinite precision because
 - short and open become difficult to realize above 100 MHz (depending on exact conditions of course)
 - RF-transistors tend to oscillate with reactive load (i.e. short)
 - Transmission lines must be considered
- Voltages and currents are difficult to measure directly. It is much easier to detect power!

Thus, we are seeking a description that is more practical

6 2-Port and S-Parameters

- S-Parameters
- Signal Flow Graphs

7 Matching

Derivation of S-Parameters I

Waves on a Transmission line:

$$\underline{U}(z) = \underbrace{U_1 \cdot e^{-\gamma z}}_{\underline{U}_+} + \underbrace{U_2 \cdot e^{\gamma z}}_{\underline{U}_-}$$
$$\underline{I}(z) = \underbrace{\frac{U_1}{Z} \cdot e^{-\gamma z}}_{\underline{I}_h} - \underbrace{\frac{U_2}{Z} \cdot e^{\gamma z}}_{\underline{I}_r}$$

for ports 1 and 2 and Z characteristic impedance of the line and $\gamma = j\beta$ (mostly complex) propagation constant

Derivation of S-Parameters I

Further derivations lead to the practical solution

$$\underline{a}(z) = A \cdot e^{-\gamma z} \quad \underline{b}(z) = B \cdot e^{\gamma z}$$

$$\underline{U}(z) = (\underline{a}(z) + \underline{b}(z)) \cdot \sqrt{Z}$$

$$\underline{I}(z) = (\underline{a}(z) - \underline{b}(z)) / \sqrt{Z}$$

solved to:

$$a(z) = \frac{1}{2} \left(\frac{U}{\sqrt{Z}} + I\sqrt{Z} \right)$$

$$b(z) = \frac{1}{2} \left(\frac{U}{\sqrt{Z}} - I\sqrt{Z} \right)$$

with $\underline{U}(z)$ and $\underline{I}(z)$:

Derivation of S-Parameters II

$$\underline{a}(z) = \frac{U_+(z)}{\sqrt{Z}} = \underline{I}_+(z) \cdot \sqrt{Z}$$

$$\underline{b}(z) = \frac{U_-(z)}{\sqrt{Z}} = -\underline{I}_-(z) \cdot \sqrt{Z}$$

S-Parameters: A Practical Convention

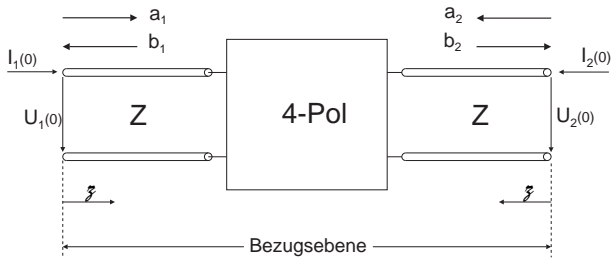

Defining waves at two-ports Measurement of the waves a_i, b_i instead of U_i, I_i

$$\begin{pmatrix} \underline{b}_1 \\ \underline{b}_2 \end{pmatrix} = \underbrace{\begin{pmatrix} S_{11} & S_{12} \\ S_{21} & S_{22} \end{pmatrix}}_{\text{scattering matrix}} \cdot \begin{pmatrix} \underline{a}_1 \\ \underline{a}_2 \end{pmatrix}, \text{ short } [b] = [S] \cdot [a]$$

Scattering Matrix and Scattering Parameter $S_{i,j}$

Physical Meaning

The physical meaning and a hint form measuring the S-Parameters

$$S_{11} = \left. \frac{b_1}{a_1} \right|_{a_2=0} \quad : \quad \text{Input-reflection for matched output}$$

$$S_{22} = \left. \frac{b_2}{a_2} \right|_{a_1=0} \quad : \quad \text{Output-reflection for matched input}$$

$$S_{21} = \left. \frac{b_2}{a_1} \right|_{a_2=0} \quad : \quad \text{Transmission factor from input to output}$$

with matched output

$$S_{12} = \left. \frac{b_1}{a_2} \right|_{a_1=0} \quad : \quad \text{Transmission factor from output to input}$$

for matched input

A Set-up for Measurement

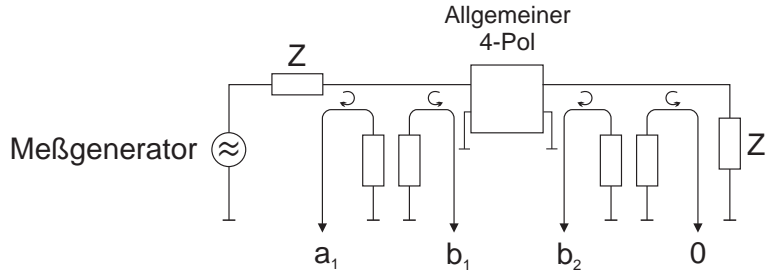

Basically, this is a vector-network-analyzer (VNWA)

Some Symmetry-Conditions

There are some symmetry-conditions for the scattering matrix. These results can be used in calculation, understanding, and in checking measurement results

- Reciprocity: $S_{21} = S_{12}$, valid in passive, isotropic (esp. non-magnetic) circuits or media. R. practically means (very loosely stated!!) that a cable can be connected the other way around, that an antenna receives and transmits with similar properties.
- Symmetric: $S_{11} = S_{22}$
- Lossless: $|S_{11}| = |S_{22}|$

The Relation to Power

Power that is being transported on a transmission line

$$P(z) = \operatorname{Re} \{ \underline{U}(z) \cdot \underline{I}^*(z) \} = | \underline{a}(z) |^2 - | \underline{b}(z) |^2$$

- Power of forward travelling wave :

$$P_h = | \underline{a}(z) |^2 = \frac{ | \underline{U}_h(z) |^2 }{ Z }$$

- backward travelling wave:

$$P_r = | \underline{b}(z) |^2 = \frac{ | \underline{U}_-(z) |^2 }{ Z }$$

Relation to Voltage and Current

a, b are calculated from voltage and current via

$$\begin{pmatrix} a \\ b \end{pmatrix} = \frac{1}{2} \begin{pmatrix} \frac{1}{\sqrt{Z_0}} & \sqrt{Z_0} \\ \frac{1}{\sqrt{Z_0}} & -\sqrt{Z_0} \end{pmatrix} \begin{pmatrix} U \\ I \end{pmatrix}$$

And vice versa

$$\begin{pmatrix} U \\ I \end{pmatrix} = \frac{1}{4} \begin{pmatrix} \sqrt{Z_0} & \sqrt{Z_0} \\ \frac{1}{\sqrt{Z_0}} & -\frac{1}{\sqrt{Z_0}} \end{pmatrix} \begin{pmatrix} a \\ b \end{pmatrix}$$

Relation to Impedance Matrix I

The impedance matrix

$$\vec{U} = \begin{pmatrix} U_1 \\ U_2 \end{pmatrix} = \begin{pmatrix} Z_{11} & Z_{12} \\ Z_{21} & Z_{22} \end{pmatrix} \begin{pmatrix} I_1 \\ I_2 \end{pmatrix} = \bar{\bar{Z}} \vec{I}$$

And so we find

$$\begin{aligned} \sqrt{Z_0} \begin{pmatrix} a_1 + b_1 \\ a_2 + b_2 \end{pmatrix} &= \bar{\bar{Z}} \frac{1}{\sqrt{Z_0}} \begin{pmatrix} a_1 - b_1 \\ a_2 - b_2 \end{pmatrix} \\ \Leftrightarrow \bar{\bar{1}} \vec{a} + \bar{\bar{1}} \vec{b} &= \frac{1}{Z_0} \bar{\bar{Z}} (\bar{\bar{1}} \vec{a} - \bar{\bar{1}} \vec{b}) \\ \Leftrightarrow \left(\bar{\bar{Z}} \frac{1}{Z_0} - \bar{\bar{1}} \right) \vec{a} &= \left(\bar{\bar{Z}} \frac{1}{Z_0} + \bar{\bar{1}} \right) \vec{b} \\ \Rightarrow \bar{\bar{S}} &= \left(\bar{\bar{Z}} \frac{1}{Z_0} + \bar{\bar{1}} \right)^{-1} \left(\bar{\bar{Z}} \frac{1}{Z_0} - \bar{\bar{1}} \right) \end{aligned}$$

Relation to Impedance Matrix II

Impedance-Matrix in S-Parameters

$$Z_{11} = Z_0 \frac{(1 + S_{11})(1 - S_{22}) + S_{12}S_{21}}{(1 - S_{11})(1 - S_{22}) - S_{12}S_{21}}$$

$$Z_{12} = Z_0 \frac{2S_{12}}{(1 - S_{11})(1 - S_{22}) - S_{12}S_{21}}$$

$$Z_{21} = Z_0 \frac{2S_{21}}{(1 - S_{11})(1 - S_{22}) - S_{12}S_{21}}$$

$$Z_{22} = Z_0 \frac{(1 - S_{11})(1 + S_{22}) + S_{12}S_{21}}{(1 - S_{11})(1 - S_{22}) - S_{12}S_{21}}$$

Relation to Impedance Matrix III

and, again, vice versa

$$S_{11} = \frac{(Z_{11} - Z_0)(S_{22} + Z_0) - Z_{12}Z_{21}}{(Z_{11} + Z_0)(Z_{22} + Z_0) - Z_{12}Z_{21}}$$

$$S_{12} = \frac{2Z_0Z_{12}}{(Z_{11} + Z_0)(Z_{22} + Z_0) - Z_{12}Z_{21}}$$

$$S_{21} = \frac{2Z_0Z_{21}}{(Z_{11} + Z_0)(Z_{22} + Z_0) - Z_{12}Z_{21}}$$

$$S_{22} = \frac{(Z_{11} + Z_0)(Z_{22} - Z_0) - Z_{12}Z_{21}}{(Z_{11} + Z_0)(Z_{22} + Z_0) - Z_{12}Z_{21}}$$

6 2-Port and S-Parameters

- S-Parameters
- Signal Flow Graphs

7 Matching

Introduction to Signal Flow Graphs (SFG)

- What is it?
 - Each S-Parameter is represented graphically by a directed line (arrow)
 - Graphical representation of the circuitry with physical meaning
- Why use it?
 - Calculation of S-Parameter circuit (without SW) leads to system of equations
 - Physical insight can be gained by looking at the SFG
 - Simple circuitries can be solved by hand, just on piece of paper.

Signal Flow Graphs (SFG): Rules



Rule 1: Concatenated graphs

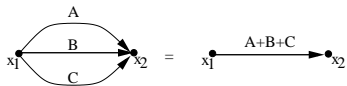

Rule 2: Parallel graphs

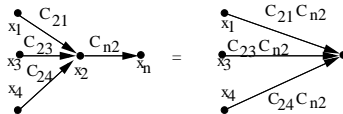

Rule 3: Nodes can be moved forth ...

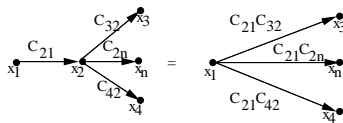

Rule 4: and back

SFG: Rule 5

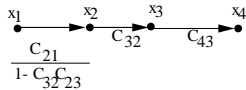
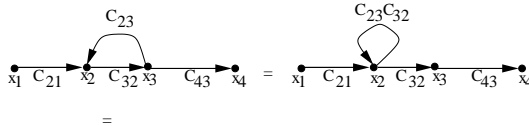

Rule 5: How to simplify a feedback loop

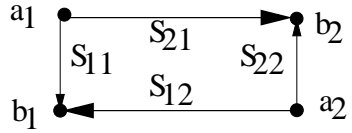

A two-port structure

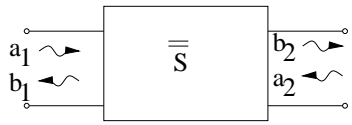

"the" S-parameter-matrix

SFG: Important Elements

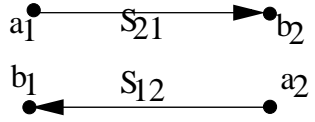

A transmission line (ideal)

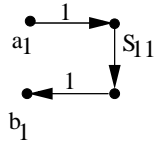

A reflection (which can be a simple load/ measurement device)

SFG: A Step in Impedance

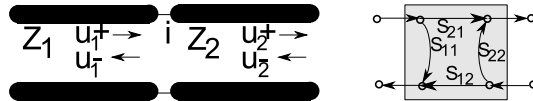

Zero length step in impedance

- Line 2 ideally matched: $u_2^- = 0 \Rightarrow S_{11} = \frac{u_1^-}{u_1^+} = \frac{Z_2 - Z_1}{Z_2 + Z_1}$
- for $S_{21} = \frac{u_2^+}{u_1^+}$: $u_2^+ = u_1^+ + u_1^- = u_1^+(1 + S_{11})$ and thus $S_{21} = 1 + S_{11} = \frac{2Z_2}{Z_1 + Z_2}$
- Subsequently $S_{22} = -S_{11}$ and $S_{12} = 1 + S_{22}$
- For normalized wave-amplitudes $a = \frac{1}{2} (u^+ / \sqrt{Z} + i^+ \sqrt{Z})$
- $S_{21}^N = S_{12}^N = S_{21} \sqrt{\frac{Z_1}{Z_2}} = \frac{2\sqrt{Z_1 Z_2}}{Z_1 + Z_2}$
- S_{11}, S_{22} unchanged

SFG: A Section of Different-Impedance Line

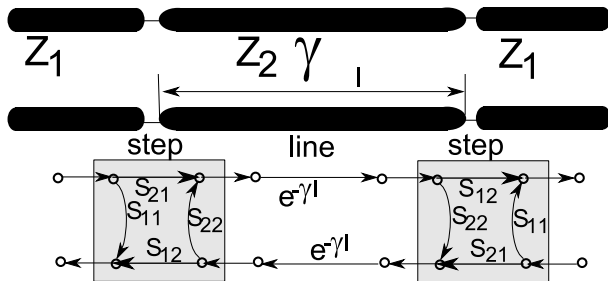

- Two steps and one ideal line element
- $S_{11} = -S_{22} = \frac{Z_2 - Z_1}{Z_2 + Z_1}$
- Un-Normalized: $S_{21} = 1 + S_{11} = \frac{2Z_2}{Z_1 + Z_2}$, $S_{12} = 1 + S_{22} = \frac{2Z_1}{Z_1 + Z_2}$
- Normalized $S_{21}^N = S_{12}^N = \frac{2\sqrt{Z_1 Z_2}}{Z_1 + Z_2}$
- Line section is only phase-shift with $e^{-\gamma l}$

SFG: Example

RF Basics

System
Overview

Fields &
Waves

Transmission
Lines

Practical TL

2-Port and
S-Parameters

S-Parameters

Signal Flow Graphs

Matching

Antennas

Passives

Transistors

Linear

Amplifier

Here, calculate and derive the example of the coupler (this at the same time introduces the coupler)

References

RF Basics

System
Overview

Fields &
Waves

Transmission
Lines

Practical TL

2-Port and
S-Parameters

S-Parameters

Signal Flow Graphs

Matching

Antennas

Passives

Transistors

Linear

Amplifier

- 5 Practical TL
- 6 2-Port and S-Parameters
- 7 Matching**
- 8 Antennas
- 9 Passive Components and Filters
- 10 Transistors: Technology, Performance

- What is matching?
- Why is it so important?
- How do I design a matching network?

- Essentially matching is all there is in RF techniques. **Basically all comes down to matching.**
- Extreme case: What is a matching network, that matches a transmission line impedance to the impedance of free space?
Answer: That is an antenna...

Basic Ingredients

- Transmission line theory
- Smith Chart
- S-Parameters
- Power and noise (if that is what we want to match)

Matching \neq Matching

Not all matchings are created equal (unlike humans)

- ① Match the waves: Design the matching network so, that the voltage ripple is minimum ($\Gamma = 0$, $VSWR=1$)
 - Between different stages in a system (e.g. between amplifier stages)
- ② Match for optimum power, optimum efficiency (complex conjugate matching)
 - Output (evtl. also input) of a (power-) amplifier
 - Input/ output to a mixer
 - Antenna (match to free space)
- ③ Match for minimum noise
 - Input to a low noise amplifier (LNA)

Only sometimes two or more of the matching goals lead to the same network!

Two Philosophies

	Resistive	Reactive only
Elements	R, L, C lines	L, C lines
Power	consumes power	no power consumption
Noise add	Adds noise	no noise added
Bandwidth	can be very broad	needs effort for broad

Most often matching networks are done with lossless elements only!

Lumped Elements in Smith Diagram (revisited)

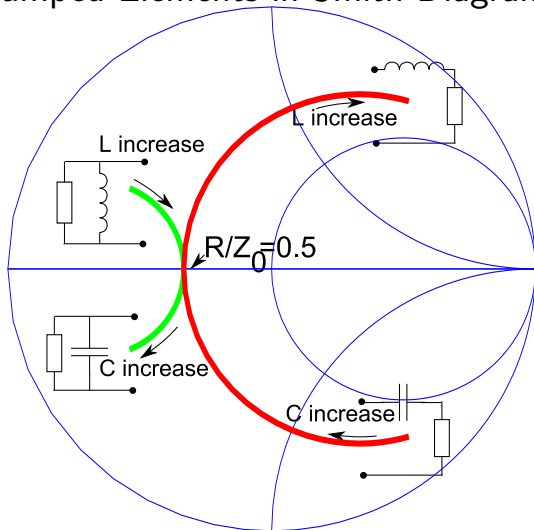

Trajectories in Smith-diagram for adjusting/ changing value of lumped elements in simple circuit configurations

Line Elements in Smith Diagram

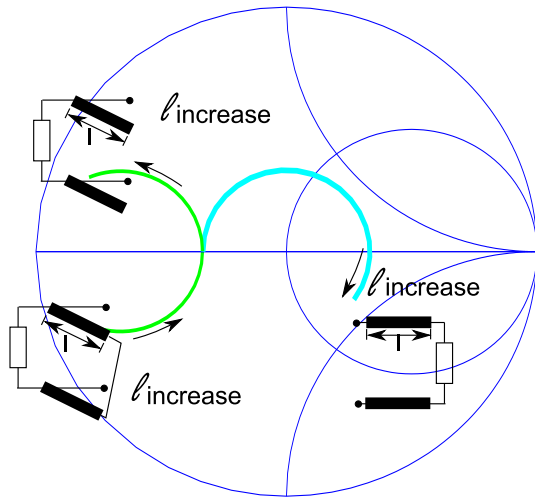

Same trajectories as before, now for series and parallel (stubs) line elements. Note that for stubs only valid for $l < \lambda/4$

Matching is Moving

What we have seen so far (just putting it together!)

- We can travel around in the smith diagram on shown different trajectories, mostly circles in the SD
- This means: With adding two reactive elements (line or L, C) you can move from somewhere in the SD to anywhere you like
- That is matching! Just moving around in the Smith chart

Here is the recipe for matching low impedance values:

- ① Mark the impedance you want to match in the SD
- ② Add series line or L, C until you cross a circle of constant B (parallel reactive elements) that goes through the target impedance
- ③ Add parallel (shunt) reactive element (stubs or again L, C) until you are on your target

Matching: A Pictorial Guide

- RF Basics
- System Overview
- Fields & Waves
- Transmission Lines
- Practical TL
- 2-Port and S-Parameters
- Matching**
- Antennas
- Passives
- Transistors
- Linear Amplifier
- Noise

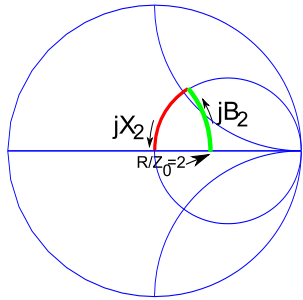
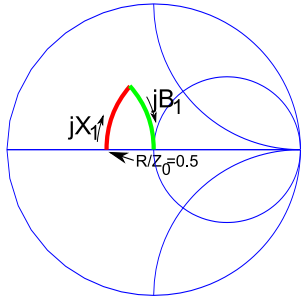
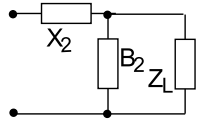
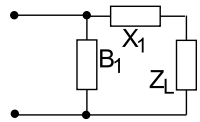

Matching: Case I

Some calculation to find the correct impedance matching circuit without running around in Smith's diagram:

- Conductance of entire circuit $Y = jB_1 + \frac{1}{Z_L + jX_1}$, and Y should become the desired value (the one that we have Z_L matched to).
- Bring this into real and imaginary part: $Y = G + jB$ $Z_L = R_L + jX_L$ and match them separately: $G + jB = jB_1 + \frac{1}{R_L + j(X_1 + X_L)} = jB_1 + \frac{R_L - j(X_1 + X_L)}{R_L^2 + (X_1 + X_L)^2}$ and now:
$$G = \frac{R_L}{R_L^2 + (X_1 + X_L)^2}, \quad B = B_1 - \frac{X_1 + X_L}{R_L^2 + (X_1 + X_L)^2}$$
- Solution is then

$$X_1 = \sqrt{\frac{R_L - GR_L^2}{G}} - X_L$$
$$B_1 = B + \frac{X_1 + X_L}{R_L^2 + (X_1 + X_L)^2}$$

- Only valid and working for $G < \frac{1}{R_L}$

Matching: Case II

Consider case II, based on already known results of case I

- Compared to case I just do exchanges

$$\begin{aligned}G &\leftrightarrow R & B &\leftrightarrow X \\B_1 &\leftrightarrow X_2 & X_1 &\leftrightarrow B_2 \\R_L &\leftrightarrow G_L & X_L &\leftrightarrow B_L\end{aligned}$$

- This is now valid in ranges

$$\begin{aligned}R &= \operatorname{Re} \left\{ \frac{1}{G + jB} \right\} = \frac{G}{G^2 + B^2} \leq \frac{1}{G} \\G_L &= \operatorname{Re} \left\{ \frac{1}{R_L + jX_L} \right\} = \frac{R_L}{R_L^2 + X_L^2} \leq \frac{1}{R_L}\end{aligned}$$

- The good news is: This fills exactly the values for R_L that were not covered by case I.
- So with these both structures each and every impedance can be matched to each and

Matching with Lines: A Pictorial Guide

- RF Basics
- System Overview
- Fields & Waves
- Transmission Lines
- Practical TL
- 2-Port and S-Parameters
- Matching**
- Antennas
- Passives
- Transistors
- Linear Amplifier
- Noise

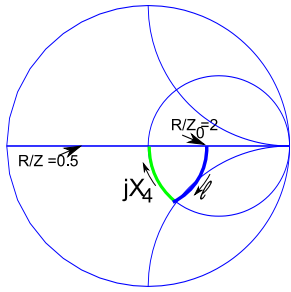
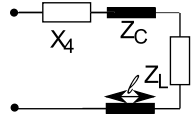
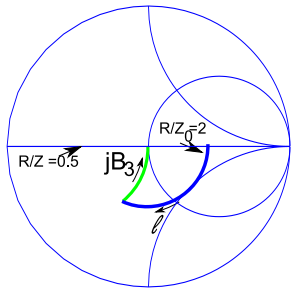
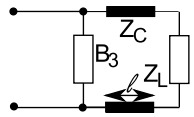

Matching: Case III (Lines)

Case III uses a transmission line with fixed (chosen) Z_c and adjustable length βl as first matching element.

- Remember, transmission lines transform impedances like (the latter valid for lossless lines) $Z_{in} = Z_c \frac{Z_L + Z_c \tanh \gamma l}{Z_c + Z_L \tanh \gamma l} = Z_c \frac{Z_L + jZ_c \tan \beta l}{Z_c + jZ_L \tan \beta l}$
- Entire conductance is thus $Y = jB_3 + \frac{1}{Z_c} \frac{Z_c + j(R_L + jX_L) \tan \beta l}{R_L + jX_L + jZ_c \tan \beta l}$
- Same game: Split in real and imaginary part and calculate
- Line-length is

$$\tan \beta l = \pm \sqrt{\left(\frac{GZ_c^2 X_L}{N}\right)^2 + \frac{Z_c R_L - Z_c G(R_L^2 + X_L^2)}{N}}$$
$$-\frac{GZ_c^2 X_L}{N} \text{ with } N = GZ_c^3 - R_L Z_c$$

Matching Case III (continued)

- And the shunt admittance

$$B_3 = B + \frac{R_L^2 t - (Z_c - X_L t)(X_L + Z_c t)}{Z_c [R_L^2 + (X_L + Z_c t)^2]}$$

$$t = \tan \beta l$$

- This now works for almost! all combination of load and source impedance
- Special case is for $N = 0$ (e.g. $R_L/Z_c = GZ_c$ (equal normalized resistance/conductance at start and end of the matching line).

$$\text{Then } t = \frac{Z_c R_L - G Z_c (R_L^2 + X_L^2)}{2 G Z_c^2 X_L}$$

- Now calculate the line-length by $\beta l = \arctan(\tan \beta l)$
- If $\beta l < 0$ add $\pi/2$ to the result (normal tangent treatment)
- Practically use the shortest line, i.e. smallest positive βl

Matching: Case IV (Lines)

In rare situation case III does not work, or in some (e.g. waveguide) technology parallel stubs are not feasible. Thus, case IV uses a stub in series (jX_4)

- $Z = R + jX = jX_4 + Z_c \frac{Z_L + Z_c \tanh \gamma l}{Z_c + Z_L \tanh \gamma l} = Z_c \frac{Z_L + jZ_c \tan \beta l}{Z_c + jZ_L \tan \beta l}$

- Line-length is

$$\tan \beta l = \pm \sqrt{\left(\frac{Z_c R X_L}{N}\right)^2 + \frac{R_L - R}{N} + \frac{Z_c R X_L}{N}}$$

with $N = R X_L^2 - R_L Z_c^2 + R R_L^2$

- And the series impedance

$$X_4 = X - Z_c \frac{-R_L^2 t + (X_L + Z_c t)(Z_c - X_L t)}{(Z_c - X_L t)^2 + R_L^2 t^2}$$

$t = \tan \beta l$

Matching: Element Realization

Element	Lumped	Distributed
$X_{1,2,4} > 0$	Inductor $j\omega L$	Series Line $l < \lambda/4$
$X_{1,2,4} < 0$	Capacitor $\frac{1}{j\omega C}$	Series Line $l < \lambda/4$
$B_{1,2,3} > 0$	Capacitor $j\omega C$	Open shunt line-stub $l < \lambda/4$
$B_{1,2,3} < 0$	Inductor $\frac{1}{j\omega L}$	Shorted shunt line-stub $l < \lambda/4$
Z_0, l	–	Series Line

- Lines should be as short as possible to reduce frequency selectivity
- All Elements (pictorial: arc in Smith-diagram) should be as small as possible to keep bandwidth as high as possible
- If Element values/ line lengths get too long: Do matching in two steps, this also increases bandwidth of the matching circuit

Power Matching (Complex Conjugate)

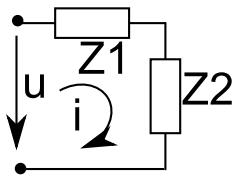

- Goal: Get maximum power (out of the generator) into the load (i.e. an amplifier) (this is $\max \{P\} = ii^* \operatorname{Re} \{Z_2\}$)
- Looking at the real part only is the fundamental difference to matching of no ripple (where real or imaginary does not matter!)
- Real Power Matching (complex conjugate) is achieved for $Z_{in}^* = Z_L$
- This is NOT minimum ripple on the transmission line (i.e. $\Gamma \neq 0$)

In Smith-chart be careful, in such cases you must note the complex conjugate of target impedance, not the “normal” one.

Noise Matching

- Goal is NOT to have maximum power or minimum ripple. Goal is to have minimum noise
- Analyze circuit (amplifier or mixer) to be matched in-depth. (this really requires to look into the noise behaviour of the amplifier)!
- Find the Γ_{opt} for minimum noise
- Simply design a matching circuitry that perfectly matches to this one.

References

RF Basics

System
Overview

Fields &
Waves

Transmission
Lines

Practical TL

2-Port and
S-Parameters

Matching

Antennas

Passives

Transistors

Linear
Amplifier

Noise

RF Basics

System
Overview

Fields &
Waves

Transmission
Lines

Practical TL

2-Port and
S-Parameters

Matching

Antennas

Maxwell's Equations

Antenna Parameters

Linear Antennas

Wave Propagation

Phased Arrays

Yagi Uda

Planar Antennas

6 2-Port and S-Parameters

7 Matching

8 Antennas

9 Passive Components and Filters

10 Transistors: Technology, Performance

11 Amplifier: Linear and Design with S-Parameters

- RF Basics
- System Overview
- Fields & Waves
- Transmission Lines
- Practical TL
- 2-Port and S-Parameters
- Matching
- Antennas**
- Maxwell's Equations
- Antenna Parameters
- Linear Antennas
- Wave Propagation
- Phased Arrays
- Yagi Uda
- Planar Antennas

How to Send and Receive: Antennas and Electromagnetic Waves in Free Space



Antennas

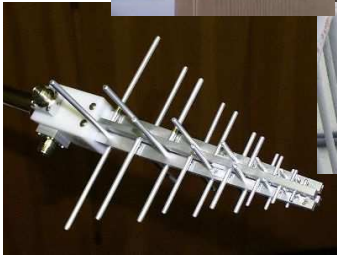
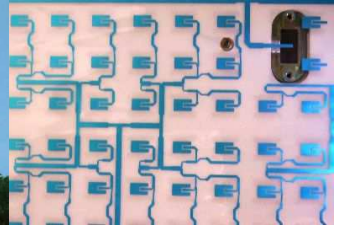

Antennas at DHBW in Karlsruhe

- RF Basics
- System Overview
- Fields & Waves
- Transmission Lines
- Practical TL
- 2-Port and S-Parameters
- Matching
- Antennas**
 - Maxwell's Equations
 - Antenna Parameters
 - Linear Antennas
 - Wave Propagation
 - Phased Arrays
 - Yagi Uda
 - Planar Antennas

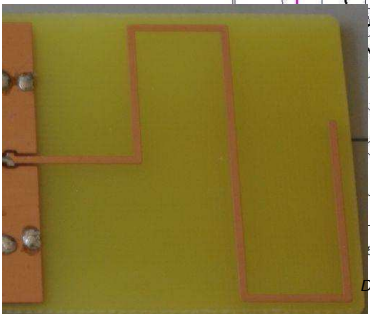
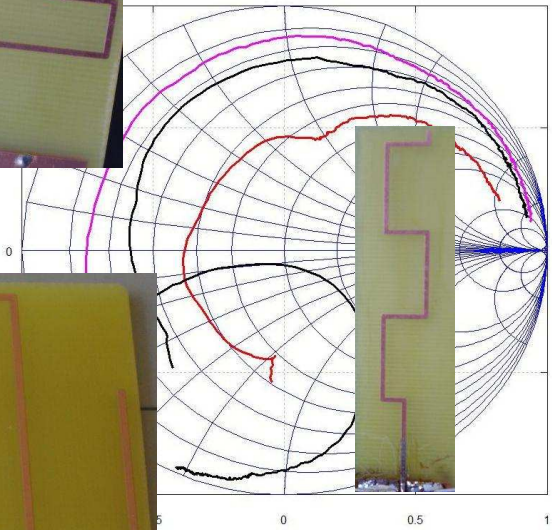
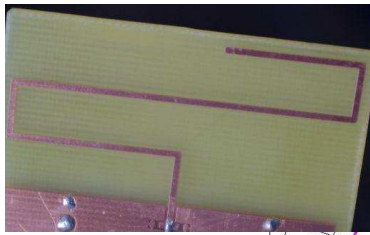

What you Learn

- Understand the basic concepts of antennas
- Have terminology and characteristics of antennas at hand
- Understand the mechanism of irradiation
- Know different types (families) of antennas
- Know basic electromagnetism
- Be able to understand and judge different antenna (full wave) simulation schemes and know how to use them

8 Antennas

- Maxwell's Equations
- Antenna Parameters
- Linear Antennas
- Wave Propagation
- Phased Arrays
- Yagi Uda
- Planar Antennas
- Small Antennas
- Mobile Antennas
- Examples in Mobile Phones
- Aperture Antennas
- Reflector

Governed by Maxwell's Equations

And God said

	Differential Form	Integral Form
Ampere's circuit law	$\nabla \times \vec{H} = \vec{J} + \frac{\partial \vec{D}}{\partial t}$	$\oint_{\partial S} \vec{H} dl = I_{f,S} + \frac{\partial \Phi_{D,S}}{\partial t}$
Faraday's law	$\nabla \times \vec{E} = -\frac{\partial \vec{B}}{\partial t}$	$\oint_{\partial S} \vec{E} dl = -\frac{\partial \Phi_{B,S}}{\partial t}$
Gauss' law (el.)	$\nabla \cdot \vec{D} = \rho$	$\oint_{\partial V} \vec{D} dA = Q$
Gauss' law (mag.)	$\nabla \cdot \vec{B} = 0$	$\oint_{\partial V} \vec{B} dA = 0$

And there was light.

Maxwell's Equations

Maxwell' equations [15, 4, 12] for time-harmonic fields (i.e. $f(t) \propto e^{-j\omega t}$, ω circular frequency $2\pi f$)

Three dimensions	One dimension (z)
$\nabla \times \vec{H} = j\omega\vec{D} + \vec{J}$	$-\frac{\partial H_y}{\partial z} = j\omega D_x + J_x$
	$\frac{\partial H_x}{\partial z} = j\omega D_y + J_y$
$\nabla \times \vec{E} = -j\omega\vec{B} - \vec{M}$	$-\frac{\partial E_y}{\partial z} = -j\omega B_x - M_x$
	$\frac{\partial E_x}{\partial z} = -j\omega B_y - M_y$
$\nabla \cdot \vec{D} = \rho$	$\frac{\partial D_z}{\partial z} = \rho$
$\nabla \cdot \vec{B} = 0$	$\frac{\partial B_z}{\partial z} = 0$

∇	$\left(\frac{\partial}{\partial x}, \frac{\partial}{\partial y}, \frac{\partial}{\partial z}\right)^T$	\vec{E}	electric field
\vec{D}	electric flux density	\vec{H}	magnetic field
\vec{B}	magnetic flux density	\vec{J}	electric current density
\vec{M}	magnetic current density	ρ	electric charge density

Constants from mother nature

ϵ_0	$8.85418 \cdot 10^{-12} \text{ As/(Vm)}$ $\approx 10^{-9}/(36\pi) \text{ As/(Vm)}$	Permittivity
ϵ_r	2 ... 12 ... 80 ... 1000s ≈ 80 $\approx 1000s$	PCB, Semiconductor (usual) Ceramics (high Diel.Const.) Ceramics Water (in GHz range) Metal
μ_0	$4\pi \cdot 10^{-7} \text{ Vs/(Am)}$ $1.25664 \cdot 10^{-6} \text{ Vs/(Am)}$	Permeability
μ_r	1 700 20,000	Mostly for us Steel μ -metal

$$\vec{D} = \epsilon_0 \epsilon_r(\omega) \vec{E}, \quad \vec{B} = \mu_0 \mu_r(\omega) \vec{H}$$

Continuity equation (from MWeq.) $j\omega\rho + \nabla \cdot \vec{J} = 0$.

The Wave Equation (Derivation)

- Assume for derivation: All space is free of sources except for electrical current (and subsequently the charge)
- Curl ($\nabla \times$) of second MWEq: $\nabla \times (\nabla \times \vec{E}) = -j\omega\mu \nabla \times \vec{H}$
- Put in first $\nabla \times \vec{H} = j\omega\epsilon \vec{E} + \vec{J}$: $\nabla \times (\nabla \times \vec{E}) = -j\omega\mu (j\omega\epsilon \vec{E} + \vec{J})$
- Reorganize and use vector identity $\nabla \times (\nabla \times V) = \nabla (\nabla \cdot V) - \nabla^2 V$
- And another of MWEq $\nabla \cdot \vec{E} = \frac{q}{\epsilon} \Rightarrow \nabla \times (\nabla \times \vec{E}) = \frac{\nabla \cdot q}{\epsilon} - \nabla^2 \vec{E} = \frac{\nabla \cdot q}{\epsilon} - \Delta \vec{E}$

$$\text{Wave-equation } \Delta \vec{E} + \omega^2 \epsilon \mu \vec{E} = j\omega\mu \vec{J} + \frac{\nabla \cdot q}{\epsilon}$$

$$\text{Or in only z-dimension } \frac{\partial^2}{\partial z^2} \vec{E} + \omega^2 \epsilon \mu \vec{E} = j\omega\mu \vec{J} + \frac{1}{\epsilon} \frac{\partial q}{\partial z}$$

Solution of the Wave Equation

Only consider the one-dimensional wave-equation.

- "Guess" the solution to be $E_x = e_x e^{\pm j k_z z}$ (other vector components similar)
- Put into the wave-equation (no sources. $\vec{J} = 0$)
- $-k_z^2 e_x + \omega^2 \epsilon \mu e_x = 0$ and all other components equally.
- Hence, equation fulfilled, if only $k_z = \pm \omega \sqrt{\epsilon \mu}$, Dimension of it is m (length) and so is $c = \frac{1}{\sqrt{\epsilon_0 \mu_0}} = 299,792,458$ m/s the speed of light (in vacuum)

Solution of the Wave Equation

- In principal this works for all field magnitudes and all derived potentials equally well with the same result.
- When all **three dimensions** show non-zero derivatives, there is
$$k^2 = \omega^2 \epsilon \mu = k_x^2 + k_y^2 + k_z^2$$
- A little more interesting is the solution of Maxwell's equations under certain boundary conditions.

The Plane Wave

- Suppose the wave is travelling in z-direction, so there is only a variation in z-direction and thus $\frac{\partial}{\partial x} = \frac{\partial}{\partial y} = 0$, then $\epsilon \nabla \cdot \vec{E} = \frac{\partial E_z}{\partial z} = 0$ and so $E_z = 0$
- ⇒ The electric field is **transversal**, it has only vector components perpendicular to the propagation direction.

- Further $\nabla \times \vec{E} = -j\omega\mu\vec{H} = \begin{pmatrix} \frac{\partial E_y}{\partial z} \\ -\frac{\partial E_x}{\partial z} \\ 0 \end{pmatrix} = -jk \begin{pmatrix} E_y \\ -E_x \\ 0 \end{pmatrix}$

And so the magnetic field is also **transversal** and can be calculated directly from the components of the electric field.

- This kind of wave is called a **transversal electro-magnetic** or **TEM** wave.

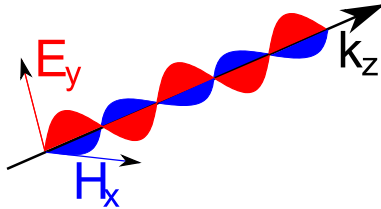

Consider electrical field only in y-direction

$$(E_y \neq 0, E_x = 0 \Rightarrow H_x = j \frac{1}{\omega \mu} \frac{\partial E_y}{\partial z})$$

- With a z-propagating wave $E_y = e_y e^{-jkz}$ do partial derivative
- $H_x = h_x e^{-jkz} = -jk \frac{1}{\omega \mu} j e_y e^{-jkz}$
- We already know $k = \omega \sqrt{\epsilon \mu}$
- And so $\frac{e_y}{h_x} = \sqrt{\frac{\mu}{\epsilon}} = Z$
- **Wave-Impedance of free space** $Z_0 = \sqrt{\frac{\mu_0}{\epsilon_0}} = 120\pi \Omega \approx 377 \Omega$
- All equally valid for other constellations of field components

- Linear Polarization: $\frac{E_x}{E_y} = c$ c is a real quantity
 - Two waves with linear polarization are orthogonal (practical use: law-enforcement radio (old), terrestrial satellite TV (channel separation))
 - Drawback: If you happen to have a receiver (geometrically) turned to receive the other polarization, you are out of luck
- Circular polarization: Field components "turn" around the propagation vector. Field components $\frac{E_x}{E_y} = \pm j$ are $\pm 90^\circ$ out of phase (i.e. $E_x = 0 \rightarrow E_y = \max$, and vice versa) [10]
 - Two kinds: Right-handed ($-j$) and Left-handed (j) circular polarized waves
 - There is also some power in some component of the electric (or magnetic) field

Flow of Energy

- We already know: In plane waves, where there is electric field, there is magnetic, and they are in phase!
- For many applications (antennas are one of them) in the end we are interested in the energy flow, not particularly in electric or magnetic field.
- **Poynting-Vector** $\vec{S} = \vec{E} \times \vec{H}^*$ defines the snapshot of the energy density.

- For our TEM-wave in z-direction this is

$$\vec{S} = \begin{pmatrix} E_y H_z^* - E_z H_y^* \\ E_z H_x^* - E_x H_z^* \\ E_x H_y^* - E_y H_x^* \end{pmatrix} = \begin{pmatrix} 0 \\ 0 \\ E_x H_y^* - E_y H_x^* \end{pmatrix}$$

- So generally energy flow is only in the direction of propagation

- Power transmitted through a surface (or even closed surface) is $P = \operatorname{Re} \left\{ \frac{1}{2} \oint_S \vec{E} \times \vec{H}^* \right\}$

(Computational) Electromagnetic

Design of Antennas (nowadays) is much of using Computational Electro-magnetics

Computational Electro-magnetics is nothing else than solving Maxwell's equations (or the wave-equation) under some boundary conditions

Boundary Conditions

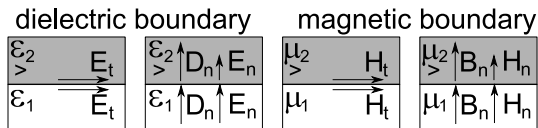

Boundary conditions on dielectric/ magnetic (possibly conducting) surfaces with normal unity vector \hat{n} [12]

- $\hat{n} \times (\vec{E}_1 - \vec{E}_2) = -\vec{M}_s$ The tangential electric field "jumps" by the magnetic surface current.
- $\hat{n} \times (\vec{H}_1 - \vec{H}_2) = \vec{J}_s$ The tangential magnetic field "jumps" by the electric surface current.
- $\hat{n} \cdot (\vec{D}_1 - \vec{D}_2) = \rho_s$ The normal dielectric flux "jumps" by the charge on the surface
- $\hat{n} \cdot (\vec{B}_1 - \vec{B}_2) = \rho_{ms}$ The normal magnetic flux jumps by the magnetic charge on the surface

Boundary Conditions on Conductors

conductor

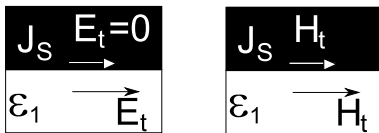

Boundary conditions on conducting surfaces with normal unity vector \hat{n}

- Ideally conducting $\hat{n} \times \vec{E}_1 = 0$ The tangential electric field is zero.
- Finite conductivity $\vec{E}_{tan1} = Z_e \vec{J}_s$ The tangential electric field can be modelled with the electric surface current and a surface resistance of the material.
- Ideally conducting $\hat{n} \times \vec{H}_1 = \vec{J}_s$ The tangential magnetic field is defined by the electric surface current. (induction).
- Finite conductivity $\vec{H}_{tan1} = Z_m \vec{J}_m$ The tangential magnetic field can be modelled with the magnetic surface current and a surface resistance of the material.

Effects of Boundary Conditions

The above boundary conditions give rise to all of the well-known observations at boundary conditions such as

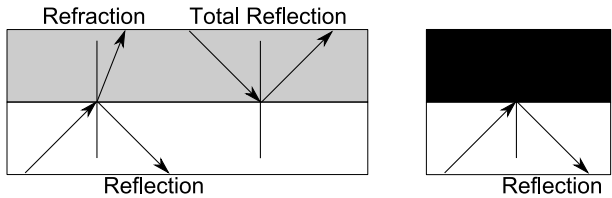

- Refraction: Change of direction of propagation, when the material (permittivity or permeability or both) changes
- Partial reflection (same thing)
- Total reflection, when a wave out of dense medium touches the surface to a less dense medium at a specific angle and under a specific polarization
- Reflection on conducting media (mirror)

8 Antennas

- Maxwell's Equations
- **Antenna Parameters**
- Linear Antennas
- Wave Propagation
- Phased Arrays
- Yagi Uda
- Planar Antennas
- Small Antennas
- Mobile Antennas
- Examples in Mobile Phones
- Aperture Antennas
- Reflector

The First Antenna

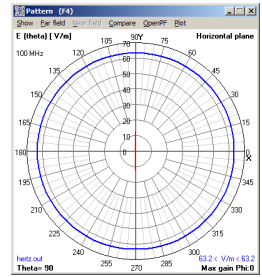
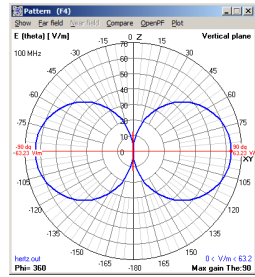
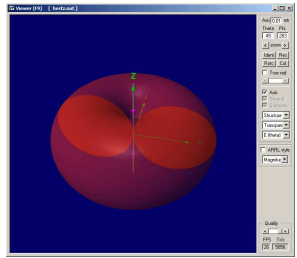
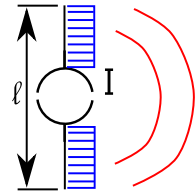

Electrically small linear antenna ($l \ll \lambda$) (Hertz's Dipole) with current feed.

Coordinate System, or What is E_θ ?

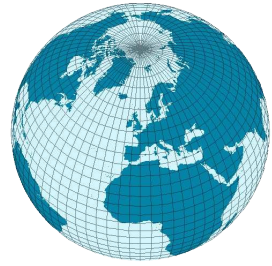

(a)

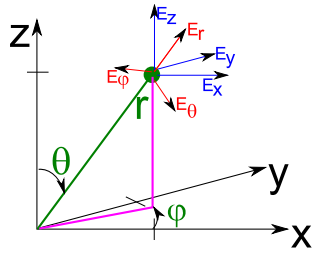

(b)

Cartesian and spherical coordinate system (b) and the earth (a) GPL, de.wikipedia.org

- Local orthogonal coordinate system [15, 3]

- Transformation of a location vector
$$\begin{pmatrix} x \\ y \\ z \end{pmatrix} \leftrightarrow \begin{pmatrix} r \\ \phi \\ \theta \end{pmatrix}$$

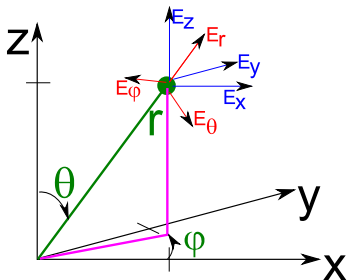

Coordinate System, or What is E_θ ? II

- Local orthogonal coordinate system [15, 3]
- Transformation of a location

$$\text{vector} \begin{pmatrix} x \\ y \\ z \end{pmatrix} \leftrightarrow \begin{pmatrix} r \\ \phi \\ \theta \end{pmatrix}$$

$$\begin{array}{l|l} r = \sqrt{x^2 + y^2 + z^2} & x = r \sin \theta \cos \phi \\ \phi = \arctan\left(\frac{x}{y}\right) & y = r \sin \theta \sin \phi \\ \theta = \arccos\left(\frac{z}{\sqrt{x^2 + y^2}}\right) & z = r \cos \theta \end{array}$$

Coordinate System, or What is E_θ ? III

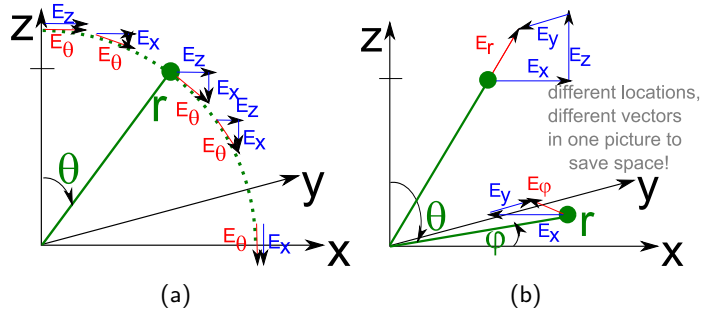

(a) Vector with only θ -component at different locations in x-z- ($\phi = 0$ or θ)-plane,
 (b) One vector with ϕ -components in x-y ($\theta = \pi/2$ or ϕ)-plane and another vector at another location with only r - (radial) component

Coordinate System, or What is E_θ ? IV

- Transformation of a vector like $\begin{pmatrix} E_x \\ E_y \\ E_z \end{pmatrix} \leftrightarrow \begin{pmatrix} E_r \\ E_\phi \\ E_\theta \end{pmatrix}$

- Into Cartesian coordinates

$$E_x = E_r \sin \theta \cos \phi - E_\phi \sin \phi + E_\theta \cos \theta \cos \phi$$

$$E_y = E_r \sin \theta \sin \phi + E_\phi \cos \phi + E_\theta \cos \theta \sin \phi$$

$$E_z = E_r \cos \theta - E_\theta \sin \theta$$

- Into Spherical coordinates

$$E_r = E_x \sin \theta \cos \phi + E_y \sin \theta \sin \phi + E_z \cos \theta$$

$$E_\theta = E_x \cos \theta \cos \phi + E_y \cos \theta \sin \phi - E_z \sin \theta$$

$$E_\phi = -E_x \sin \phi + E_y \cos \phi$$

- Note: ϕ, θ are related to the LOCATION, where the vector is present, not the angles between components of the vector.

Field Components: Some Remarks

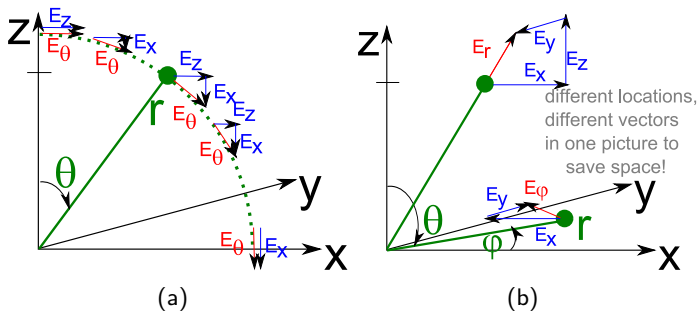

- Radial component (E_r) is an outward bound component, thus for a spherical TEM-wave radiated from the origin it is zero.
- $E_\theta = \pm (E_x \cos \phi + E_y \sin \phi)$ at the vertical z-axis ($\theta = 0, \pi$)
- $E_\theta = -E_z$ everywhere in the x-y plane
-

E_ϕ independent of θ (elevation angle), $E_\phi = E_y$ on x-axis and $E_\phi = -E_x$ on y-axis

And Now Again: The First Antenna

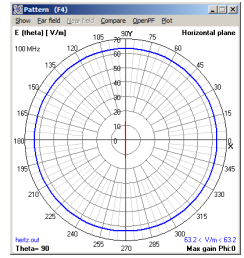
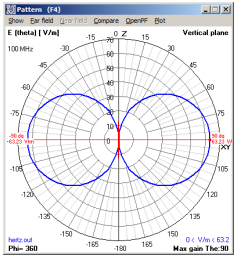
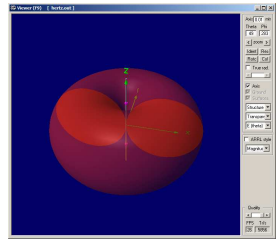
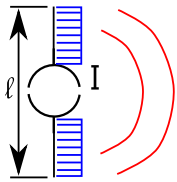

Electrically small antenna ($l \ll \lambda$) with current feed. Current is constant on the wire. ... And it's far field pattern

- RF Basics
- System Overview
- Fields & Waves
- Transmission Lines
- Practical TL
- 2-Port and S-Parameters
- Matching
- Antennas
 - Maxwell's Equations
 - Antenna Parameters
 - Linear Antennas
 - Wave Propagation
 - Phased Arrays
 - Yagi Uda
 - Planar Antennas

Radiation Pattern

- RF Basics
- System Overview
- Fields & Waves
- Transmission Lines
- Practical TL
- 2-Port and S-Parameters
- Matching
- Antennas
 - Maxwell's Equations
 - Antenna Parameters
 - Linear Antennas
 - Wave Propagation
 - Phased Arrays
 - Yagi Uda
 - Planar Antennas

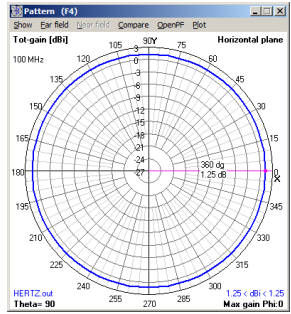
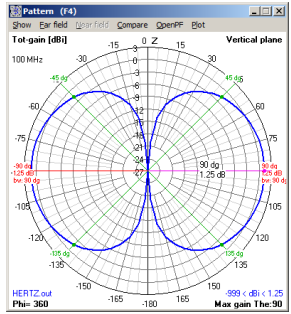

- **Radiation Pattern:** [6]

radiation pattern: 1. The variation of the field intensity of an antenna as an angular function with respect to the axis. (188) Note: A radiation pattern is usually represented graphically for the far-field conditions in either horizontal or vertical plane.

- **Radiation Pattern** (continued)

- Describes the strength of the field at certain points in space.
- Sometimes 3-dimensional (very nice, but difficult to quantify)
- Most often as 2-dimensional cuts (e.g. x-y-plane, x-z-plane)
- We are most concerned with far-field radiation pattern
- Often given in (dB), in this case relative to isotropic radiator (dBi). So this is relative to the antenna that radiates its power equally to all directions

E & H-Plane

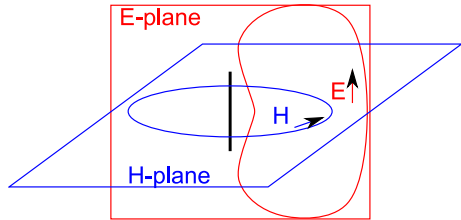

- **E-plane:** The plane that is parallel to the vector of electric field (here this is any vertical plane (e.g. x-z-plane))
- **H-plane:** The plane that is parallel to the vector of the magnetic field (here this is the horizontal (x-y)-plane)

Nice, But Not-existing: Isotropic Antenna

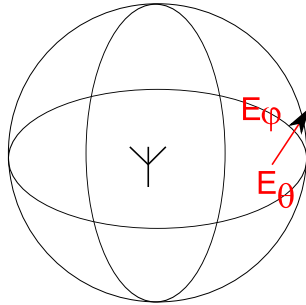

- Imagine an antenna that radiates equally in all directions
- Its electrical field would be like $E_{\theta} = E_{\phi} \propto \frac{e^{-jkr}}{4\pi r}$
- Standard antenna to compare all the others to
- Radiates its power P equally distributed to all directions, so that power density is $S = \frac{P}{4\pi r^2}$

Further Parameters: Gain & Directivity

- **Directivity, Gain** [6, 14]

antenna gain: The ratio of the power required at the input of a loss-free reference antenna to the power supplied to the input of the given antenna to produce, in a given direction, the same field strength at the same distance. Note 1: Antenna gain is usually expressed in dB. Note 2: Unless otherwise specified, the gain refers to the direction of maximum radiation. The gain may be considered for a specified polarization. Depending on the choice of the reference antenna, a distinction is made between:

- absolute or isotropic gain (G_i), when the reference antenna is an isotropic antenna isolated in space;
 - gain relative to a half-wave dipole (G_d) when the reference antenna is a half-wave dipole isolated in space and with an equatorial plane that contains the given direction;
 - gain relative to a short vertical antenna (G_r), when the reference antenna is a linear conductor, much shorter than one quarter of the wavelength, normal to the surface of a perfectly conducting plane which contains the given direction.
- [RR] (188) Synonyms gain of an antenna, power gain of an antenna.

Gain, Directivity, & Power

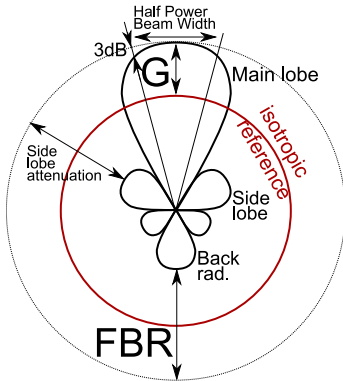

- Mostly used: **isotropic gain**, relative to the isotropic antenna
- Potential loss of antenna included in gain.
- Gain of **small dipole**: $G_i = 1.76 \text{ dB} = 1.5$, for 100% radiation efficiency
- Gain of **half wave dipole**:
 $G_i = 2.16 \text{ dB} = 1.64$,
- **EIRP** Effectively isotropic radiated power:
Power delivered to an **isotropic** antenna to generate the same field strength:
 $EIRP = P_t G_i$, P_t : total power delivered to the antenna.
- **ERP** as above but referenced to **half wave dipole**

Parameters for Power and Circuits I

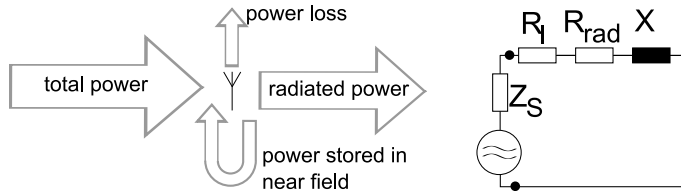

- Two kinds of power make the total power P_t (e.g. [10])

- ① Power radiated P_{rad}
- ② Power lost in the antenna (network) P_l

$$P_t = P_{rad} + P_l$$

- **Antenna efficiency** $\eta = \frac{P_{rad}}{P_t}$ (for our simulated small dipole $\eta = 89\%$ reached).

Parameters for Power and Circuits II

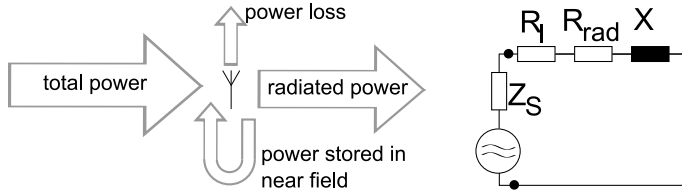

● Definition of power allows definition of resistors:

- ① **Radiation resistance** $R_{rad} = 2 \frac{P_{rad}}{I^2} = 2 \frac{U^2}{P_{rad}}$
- ② **Loss resistance** $R_l = 2 \frac{P_l}{I^2} = 2 \frac{U^2}{P_l}$
- ③ **Total Antenna resistance** is thus $R_t = R_l + R_{rad} + jX$ and this is the one we need to match the circuit to

Some Analytics on the Small Dipole

- Field of the small dipole is the solution of the wave equation excited by a very small current element.

- Generalized Solution of the wave-equation $(\Delta + k^2)G(\vec{r}, \vec{r}') = \delta(\vec{r} - \vec{r}')$

- In different dimensions [12]

Dimension	Green's Function G	Singularity
1	$-\frac{j}{2k} e^{jk x-x' }$	—
2	$-\frac{j}{4} H_0^{(1)}(k \vec{r} - \vec{r}')$	$\ln(\vec{r} - \vec{r}')$
3	$-\frac{1}{4\pi} \frac{\exp(-jk \vec{r} - \vec{r}')}{ \vec{r} - \vec{r}' }$	$\frac{1}{ \vec{r} - \vec{r}' }$

$H_0^{(1)}$ is Hankel-function first kind, order zero

- To get the electric field out of a current density distribution use

$$\vec{E} = \int_V \left(-j\omega\mu\vec{I} - \frac{j}{\omega\epsilon} \nabla' \cdot \nabla' \cdot \right) G \vec{J} dv' \vec{I}$$
 is the unity matrix and ' denote operation at source location.

More Analytics

In the end the field of the electrical small antenna (current filament) with current I and length l [10, 15]

- $E_r = Z_0 \frac{Il \cos \theta}{2\pi r^2} \left(1 + \frac{1}{jkr}\right) e^{-jkr}$ decaying fast with $\propto \frac{1}{r^2}$
- $E_\theta = jZ_0 \frac{kIl \sin \theta}{4\pi r} \left(1 + \frac{1}{jkr} - \frac{1}{(kr)^2}\right) e^{-jkr}$
- $H_\phi = j \frac{kIl \sin \theta}{4\pi r} \left(1 + \frac{1}{jkr}\right) e^{-jkr}$

- In **Far Field** (i.e. $r > \frac{2l^2}{\lambda}$) $E_r = 0$ and electric and magnetic field are in phase
- Example

Name	l or d	$r > \dots$
Dipol	$\lambda/2$	$\lambda/2$
Parabolic	20λ	800λ
Laser		
$(\lambda = 632 \text{ nm})$	1 mm	3.16 m

What is Wrong with the Small Antenna?

Why does not everybody just use the small linear antenna? It radiates, it is small, so what is wrong with it?

- It is more an open than an antenna (very low real part of the antenna impedance, but very high (negative) imaginary)
- You almost get no power into it
- Very ineffective, impossible to match, very high reactance since it is essentially an open

- RF Basics
- System Overview
- Fields & Waves
- Transmission Lines
- Practical TL
- 2-Port and S-Parameters
- Matching
- Antennas
 - Maxwell's Equations
 - Antenna Parameters
 - Linear Antennas**
 - Wave Propagation
 - Phased Arrays
 - Yagi Uda
 - Planar Antennas

- 8 Antennas
 - Maxwell's Equations
 - Antenna Parameters
 - Linear Antennas**
 - Wave Propagation
 - Phased Arrays
 - Yagi Uda
 - Planar Antennas
 - Small Antennas
 - Mobile Antennas
 - Examples in Mobile Phones
 - Aperture Antennas
 - Reflector

$\lambda/2$ -Dipole

What can be better than a small antenna stub?

- Resonance.....
- Simply remember from transmission line theory: An open transformed over a $\lambda/4$ line turns out to be an open... (this at least brings the reactance into manageable regions)

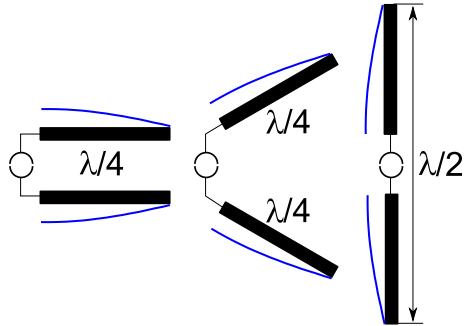

Pattern of the $\lambda/2$ -Antenna

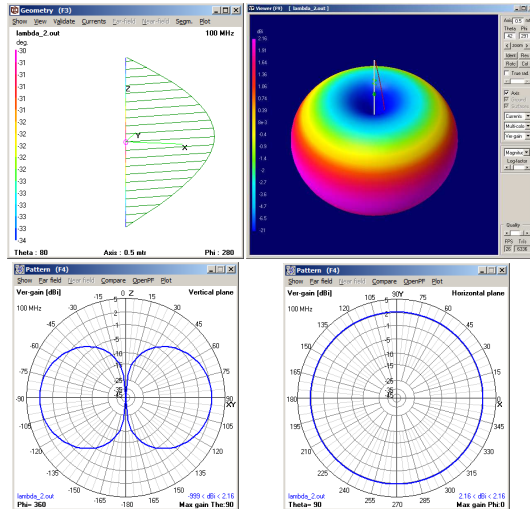

Parameter of the $\frac{\lambda}{2}$ - dipole are $Z = (77.4 + j45.4) \Omega$, Gain $G_i = 2.16$ dBi, vertical polarization.
This thing is matchable.

More on the Wire-Antenna

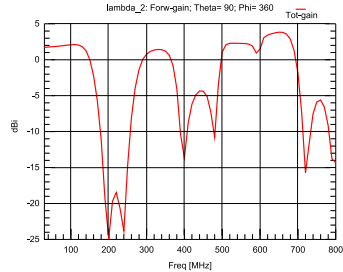
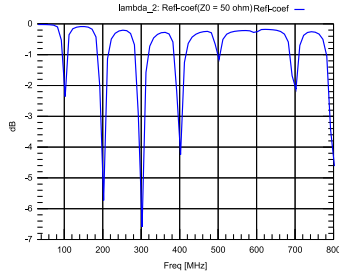

Simulation on wire antenna with length $l=1.5$ m ($\lambda/2$ at 100 MHz)

- Note distinct (and sharp) resonances
- Granted, also reflection of -2.4 dB (at 100 MHz) is not good, but here, we can easily design a matching network
- Note, how the forward gain changes.
- See NEC-Simulation of lambda_2.nec over 30 to 800 MHz, browse through the gain-pattern vs. frequency

Patterns of Wire Antennae

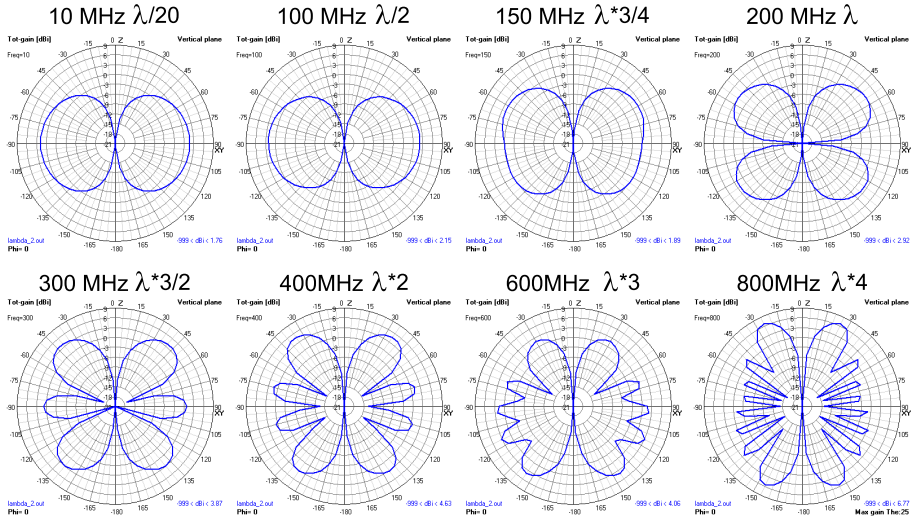

Radiation patterns for a 2×1.5 m long symmetrical wire antenna for various frequencies.

More to Know

- **Ground-effects** and how to use ground in antenna design ($(\lambda/4)$ -Monopoles)
- (Finite) **thickness** and (finite) **conductivity** of the wire antenna (lower quality factor, higher band-width)
- Propagation of waves in the **atmosphere** (Ground-wave, reflection and transmission through the ionosphere (Short-Wave radio and Satellite (GPS & TV)))
- Concept of **effective area** of an antenna
- Connecting unbalanced antennas to balanced circuit design (the **BALUN**)
- More on **polarization** (polarization ellipsoid and Poincare-sphere, cross-polarization)

NEC: How is this Calculated?

What is NEC [11]

The Numerical Electromagnetics Code (NEC), credited to Gerald Burke, is an algorithm and generic computer application, originally written in FORTRAN. Developed in the 1970s, it is a popular antenna modeling method for wire and surface antennas. The code was made publicly available for general use and has subsequently been distributed for many computer platforms from mainframes to PCs.

NEC models can include wires buried in a homogeneous ground, insulated wires and impedance loads. The code is based on the method of moments solution of the electric field integral equation for thin wires and the magnetic field integral equation for closed, conducting surfaces. The algorithm has no theoretical limit and can be applied to very large arrays or for detailed modeling of very small antenna systems.

Models are defined as elements of wire or similar as an input text file (typically in ASCII). They are then input into the NEC application to generate tabular results. The results can then be input into subsequent 'helper' applications for visual viewing and the generation of other graphical representations as smith charts, etc.

I am using 4nec2 available from <http://home.ict.nl/~arivoors/>.

Further information (Manuals etc.) are also found on <http://www.nec2.org/>.

Method of Moments

How to numerically calculate such problems (focus here is on wire-grids, but - with few modifications - also generally working)

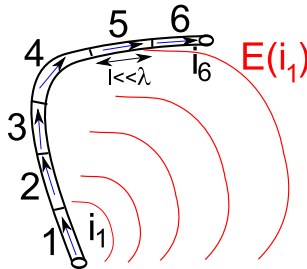

1. Divide the wire structure into many small current elements i_k (just as the small antennas) $\vec{J}(\vec{r}') = \sum_{k=1}^N i_k \vec{b}_k(\vec{r}')$ (k are base-functions, \vec{r}' just a local coordinate)
2. Calculate the (electric or magnetic) field from each of the current elements (let's take

$$i_k) \vec{E}_k(\vec{r}) = \int_{l'} \overline{\overline{G}}(\vec{r} - \vec{r}') i_k \vec{b}_k(\vec{r}') dr'$$

Method of Moments II

3. Now "measure" how much all the other antennas receive of this field (let's take receiver element j)

$$z_{k,j} = \int_l \vec{b}_j(\vec{r}) \left(\int_{l'} \overline{\overline{G}}(\vec{r} - \vec{r}') i_k \vec{b}_k(\vec{r}') dr' \right) dr$$

4. Tabulate all these "reaction" values into a (big) matrix $\overline{\overline{Z}}$, multiply it by the value of the current elements and equate it to the vector of the excitation current $\overline{\overline{Z}}\vec{I} = \vec{I}_E$ or as an example for three elements

$$\begin{pmatrix} z_{11} & z_{12} & z_{13} \\ z_{21} & z_{22} & z_{23} \\ z_{31} & z_{32} & z_{33} \end{pmatrix} \cdot \begin{pmatrix} i_1 \\ i_2 \\ i_3 \end{pmatrix} = \begin{pmatrix} 0 \\ i_{E2} \\ 0 \end{pmatrix}$$

5. Solve the equation $\vec{I} = \overline{\overline{Z}}^{-1} \vec{I}_E$
6. And now further process \vec{I} for example to calculate the radiated field, or to calculate an efficiency and so on.

Method of Moments Discussed

- + Around since a long time (1960s, NEC from 1970)
 - + Very well suited for geometries with infinite homogeneous media, exceptionally suited for wire structures
 - + Adapted to planar structures (like micro-strip circuits)
 - + Many "tricks" and extensions exist to calculate virtually every problem
-
- Each current elements reacts with all others: full (densely populated) matrix
 - Calculation of integrals (because of singularity) often cumbersome
 - Difficult to handle 3-dimensional structures → every boundary must be modelled with current (or charge) elements, thus matrix not only dense, but also huge
- ⇒ Matrix solution will slow down the process

Lorentz Reciprocity Theorem

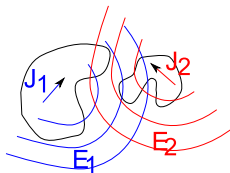

- State only result and consequences (some), derivation involves a lot of vector calculus and assumptions on surface integrals [4]
- Result $\int_V \vec{E}_1 \cdot \vec{J}_2 dV = \int_V \vec{E}_2 \cdot \vec{J}_1 dV$
- For infinitesimal current elements $\vec{E}_1 \cdot \vec{J}_2 = \vec{E}_2 \cdot \vec{J}_1$
- Main consequence: A system of two antennas (one transmit, one receive) can be turned around and exhibits the same characteristic
- An antenna has the same characteristic in transmit and receive operation.

8 Antennas

- Maxwell's Equations
- Antenna Parameters
- Linear Antennas
- **Wave Propagation**
- Phased Arrays
- Yagi Uda
- Planar Antennas
- Small Antennas
- Mobile Antennas
- Examples in Mobile Phones
- Aperture Antennas
- Reflector

A Communication System

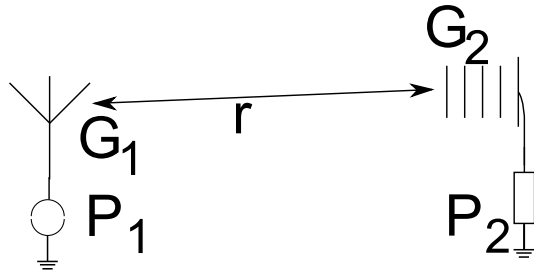

- Power received at Antenna 2 (and used in the resistor) is $\frac{P_2}{P_1} = G_1 G_2 \left(\frac{\lambda}{4\pi r}\right)^2$

- Or in dB

$$\frac{P_2}{P_1} \Big|_{dB} = G_1|_{dB} + G_2|_{dB} - 20 \log_{10} \left(\frac{r}{1 \text{ km}}\right) - 20 \log_{10} \left(\frac{f}{1 \text{ GHz}}\right) - 92.44 \text{ dB}$$

The last term includes the 4π and speed of light.

System Examples

Parameter	Bluetooth	GSM	Astra 1E
P_1	10 dBm	2 W	85 W
G_1/dB	0	0	32
EIRP	10 dBm	33 dBm	51 dBW
G_2/dB	0	11	35
f/GHz	2.4	0.9	12
λ/cm	12.5	33.3	2.7
r	10 m	35 km	36,000 km
$\left(\frac{\lambda}{4\pi r}\right)^2 / \text{dB}$	-60	-122.4	-204
$P_2/P_1/\text{dB}$	-60	-111.4	-137
P_2	-50.0 dBm	-78,4 dBm	1.6 pW

Colored quantities are input

Comments

- GSM: (Free space) received power does not limit range (Sens. BTS -104 dBm)
- Sat-TV: Note the exceptionally low received power! Noise power in 10 MHz band is -104 dBm=0.04 pW (SNR=16 dB) in best case scenario.

Fresnel-Zones

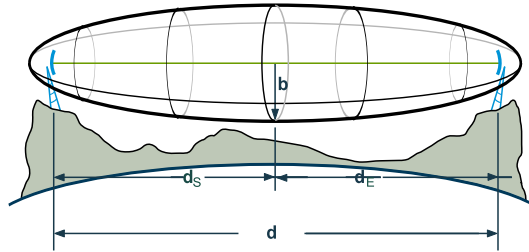

Fresnel ellipsoid (source: Wikipedia (modified), GPLD)

- Antenna are in the focal point of the ellipsoid
- Ellipsoid generated such that path difference between outer rim and direct path is max. $\frac{\lambda}{2} \rightarrow$ most of the energy is transmitted within this zone.
- If disturbances within this zone occur, they will directly affect path loss (covering it half increases PL by 6 dB)
- Width b of the zone at a distinct location is $b = \sqrt{\frac{n \cdot \lambda \cdot d_S \cdot d_E}{d}}$, $b_{max} = 0.5 \cdot \sqrt{\lambda \cdot d}$

Wave-Propagation in Not-So Free Space

- Wave propagation disturbed by
 - Obstacles
 - Fringing
 - Reflection etc.
- Free space model just seen represents a best case scenario
- For e.g. IEEE 802.15.4 communication systems the scenario is usually adopted like

$$\frac{P_2}{P_1} \Big|_d = \begin{cases} pl(1\text{m}) - 10\gamma_1 \log(d) & d \leq 8\text{m} \\ pl(8\text{m}) - 10\gamma_8 \log(d/8) & d > 8\text{m} \end{cases}, \quad pl(1\text{m}) = 20 \log\left(\frac{4\pi f}{c_0}\right)$$

With values

Parameter	900 MHz	2400 MHz
$pl(1\text{m})$	-31.53 dB	-40.2 dB
$pl(8\text{m})$	-49.59 dB	-58.5 dB
γ_1	2 dB	2 dB
γ_8	3.3 dB	3.3 dB

Path-Loss Models at GHz Communication

Example: Take the path-loss models that base ZigBee (IEEE 802.15.4) [1]

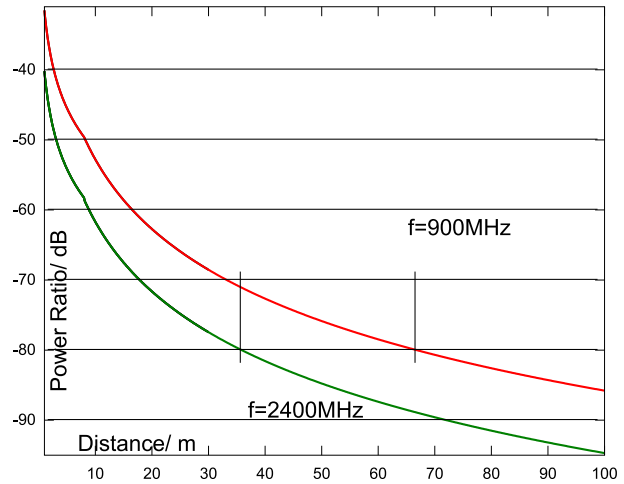

(Possible) Goals for Antenna Design

- Small, cheap, easy to manufacture, easy to hide (in hand-set or in car)
- Mechanics (e.g. wind resistance)
- Efficient
- Exhibiting the desired radiation pattern
 - High-Gain (directive) vs. isotropic
 - Polarization (vertical/ horizontal, left/ right circular)
- Broadband, at least over the entire range of interest, which is sometimes multi-standard (FM-radio and TV, GSM800/900/1800 and UMTS, FM-radio and GPS,...)
- Beam can be steered (Radar and target seeking applications, TV-SAT for mobile, cellular for higher efficiency)

8 Antennas

- Maxwell's Equations
- Antenna Parameters
- Linear Antennas
- Wave Propagation
- **Phased Arrays**
- Yagi Uda
- Planar Antennas
- Small Antennas
- Mobile Antennas
- Examples in Mobile Phones
- Aperture Antennas
- Reflector

Phased Arrays

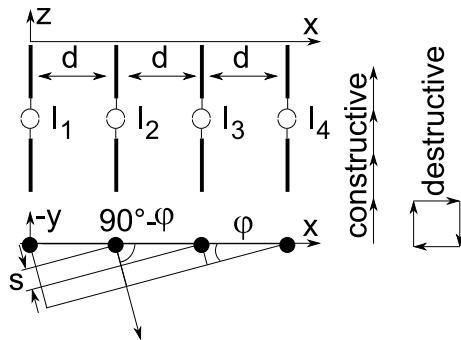

- Arrange multiple (general N , here: 4) dipoles
- Feed them (we need to discuss how) with the desired phase relation ($I_2 = I_1 e^{j\alpha}$) between them
 1. Broadside (y -direction, $\phi = 0$) radiation: $\alpha = 0$
 2. For other direction α must compensate the phase-difference β out of different distance to observation $s = d \sin \phi$. $\beta = 2\pi \frac{s}{\lambda}$

Phased Array II

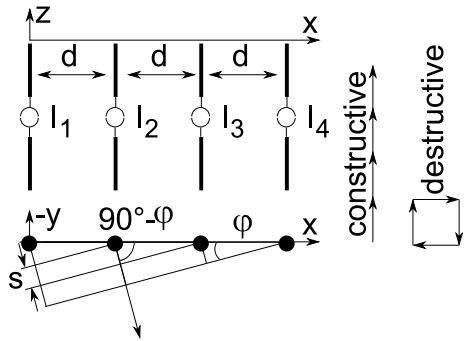

- Feeding continued

3. Generally maxima occur for $\beta - \alpha = 2\pi n$, which is (simplest possible)

$$\alpha = \beta = 2\pi \frac{d}{\lambda} \sin \phi.$$
4. In-axis radiation (x -direction, $\phi = 90^\circ$) requires $d = \lambda$

Phased Array III

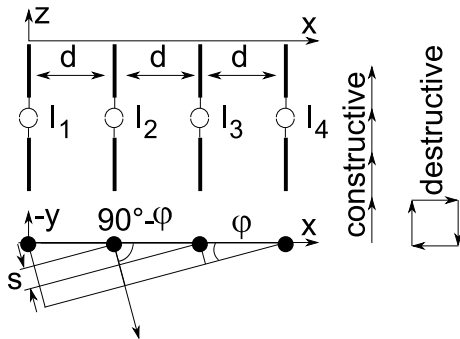

- Seeking the minima, that are found with $\sum_{k=0}^N e^{j(k\alpha - k\beta)} = 0$
- Minima are at $N(\beta - \alpha) = 2\pi n \Leftrightarrow \beta - \alpha = \frac{2\pi n}{N}$
- For broadside and all equal phase ($\alpha = 0$) there is $\beta = \frac{2\pi}{N} = 2\pi \frac{d \sin \phi}{\lambda}$
- Total width of the main lobe is $2\phi = \arcsin\left(\frac{\lambda}{Nd}\right)$

Phased Array Patterns

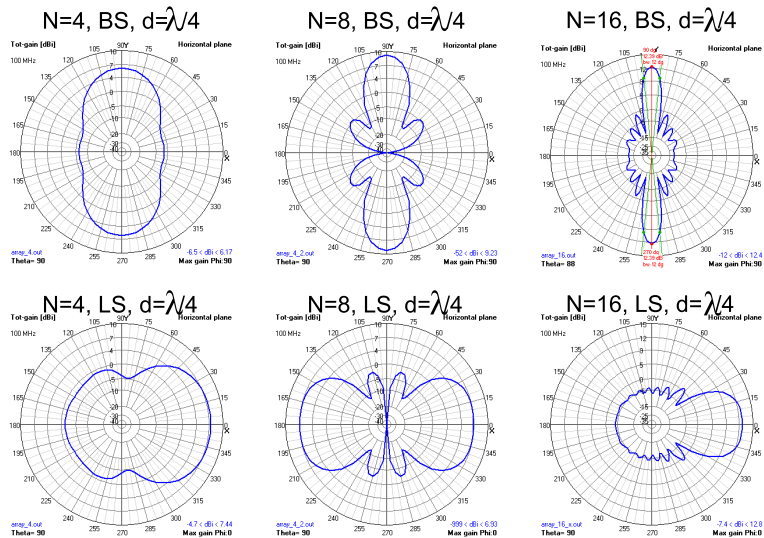

Differently phased and spaced linear arrays

More Antenna Characteristics

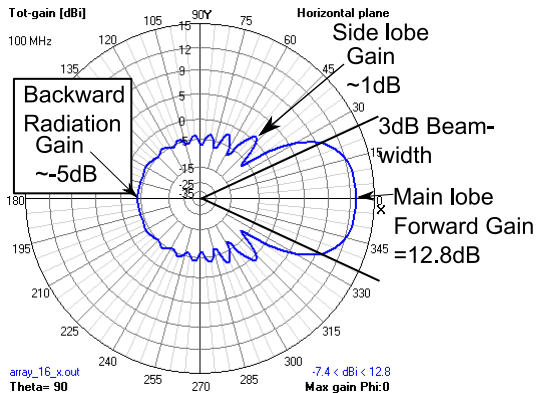

- 3 dB Beam-width defined as the angle between both $G_{max} \pm 3$ dB-lines (here $\approx 45^\circ$)
- Side-lobe attenuation $G_{max}/G_{sidelobe}$ (here ≈ 11.8 dB)
- Front-to-Back-Ratio G_{max}/G_{back} (here ≈ 17 dB)

Feeding Network

- Above we had the luxury of having an individual feed for each antenna
 - Most flexible
 - Most expensive
 - Only used where absolutely needed (e.g. digital beam forming)
- Usually feed via transmission lines of correct length
- Many different configurations are possible, esp. for directing the beam (Butterfly-matrix, Rotman-lens)

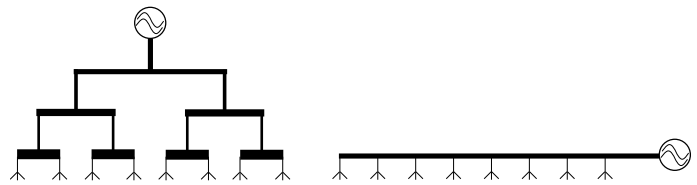

Examples for feed-lines (hierarchal and series)

8 Antennas

- Maxwell's Equations
- Antenna Parameters
- Linear Antennas
- Wave Propagation
- Phased Arrays
- **Yagi Uda**
- Planar Antennas
- Small Antennas
- Mobile Antennas
- Examples in Mobile Phones
- Aperture Antennas
- Reflector

Yagi-Uda Antenna

Commonly used directive antenna for radio and TV reception

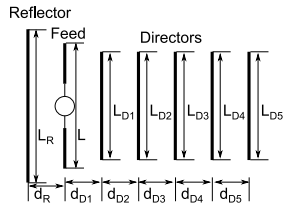

- Composed of (roughly) three sections
 - ① Feed antenna (folded, or $\lambda/2$ -dipole)
 - ② Directors $L_D < L$, act as transmission line structure, that guides a surface wave
 - ③ Reflector $L_R > L$, usually only one, can also be build as a reflecting grid
- Homogeneous (all directors equally) and in-homogeneous (directors individually optimized)

Yagi Antenna Design

Some designs for in-homogeneous Yagi-Uda antennas after classical paper [18] "Yagi Antenna Design"

N	d/λ	L_R/λ	L/λ	L_{D1}/λ	L_{D2}/λ	L_{D3}/λ	L_{D4}/λ	L_{D5}/λ	L_{D6}/λ	L_{D7}/λ	L_{D8-N}/λ
0	0.2	0.482	0.453								
1	0.2	0.482	0.453	0.424							
3	0.2	0.482	0.455	0.428	0.424	0.428					
4	0.25	0.482	0.455	0.428	0.42	0.42	0.428				
10	0.2	0.482	0.457	0.432	0.415	0.407	0.398	0.39	0.39	0.39	0.39
15	0.2	0.482	0.455	0.428	0.42	0.407	0.398	0.394	0.39	0.386	0.386
13	0.308	0.475	0.4495	0.424	0.424	0.42	0.407	0.403	0.398	0.394	0.39

Simulation done at $f = 100$ MHz ($\lambda = 2.99$ m). Wire radius (this is critical!) is 1.3 mm

N	d/λ	G/dB
0	0.2	6.38
1	0.4	9.07
3	0.8	11.2
4	1.25	12.4
10	2.2	14.1
15	3.2	15.4
13	4.312	15.4

Pattern of Yagi Antennas

yagi 0,1,3,4

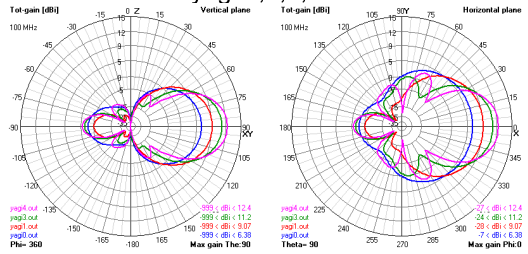

yagi 10,13,15

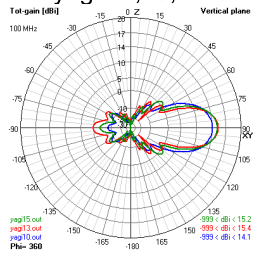

yagi 15

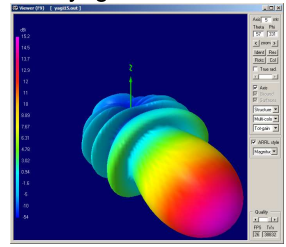

Radiation patterns for the afore mentioned design values

Yagi: Results

- Gain of a Yagi-Antenna depends much on size (length of the structure), less on actual number of elements
- Radius of wire is important (as reactance of directors is used to adjust the phase velocity of the surface waves on the director section)
- Length of feeding antenna does not much influence the overall directivity and may thus be chosen for optimum match

Planar Yagi

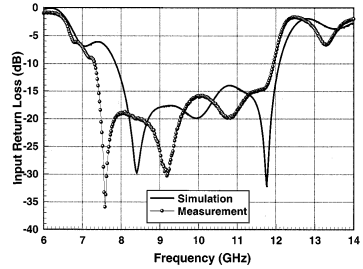
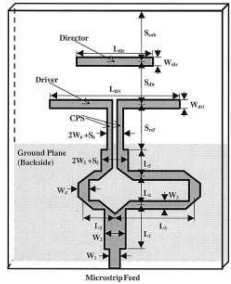

- Yagi in micro-strip-technology (for about 10 GHz) [8] for use in an array, design-focus is band-width
- Note: Ground-plane is reflector, Balun for symmetric feed
- Substrate $h = 0.635$ mm, $\epsilon_r = 10.2$ (RT Duroid) $L_{dri} = 8.7$, $L_{dir} = 3.3$ mm, total area about $(\lambda_0/2)^2$
- $FBR > 12$ dB, $G = 3 \dots 5$ dB

More to Know on Wire Antennas

- Increase bandwidth through tapering (e.g. log-periodic (dipole) design). Bandwidth multi-octave possible.
- Self-complementary antennas (possible more metal-sheet antennas) (Babinet-principle)
- Helix-antenna

- RF Basics
- System Overview
- Fields & Waves
- Transmission Lines
- Practical TL
- 2-Port and S-Parameters
- Matching
- Antennas
 - Maxwell's Equations
 - Antenna Parameters
 - Linear Antennas
 - Wave Propagation
 - Phased Arrays
 - Yagi Uda
 - Planar Antennas**

- 8 Antennas
 - Maxwell's Equations
 - Antenna Parameters
 - Linear Antennas
 - Wave Propagation
 - Phased Arrays
 - Yagi Uda
 - Planar Antennas**
 - Small Antennas
 - Mobile Antennas
 - Examples in Mobile Phones
 - Aperture Antennas
 - Reflector

Micro-strip Patch Antenna

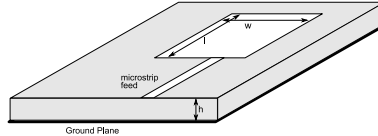

- Nothing more than a structure (simplest: rectangle) on a substrate with appropriate feed.
- Very popular, since can be easily integrated with micro-strip circuit
- About a zillion different designs, rules, applications, modifications etc. exist for a lot of purposes

Micro-strip Patch Antenna II

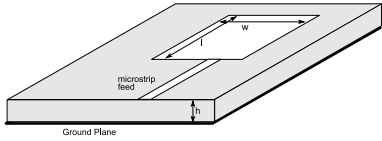

- Operation determined by $\lambda/2$ -resonance.
- Dependent on excited mode $f_c \approx \frac{c}{2L\sqrt{\epsilon_r}}$ or $f_c \approx \frac{c}{2W\sqrt{\epsilon_r}}$ or mixture thereof
- Operation is to radiate through the slots at the edges of the patch

Micro-strip Patch Antenna III

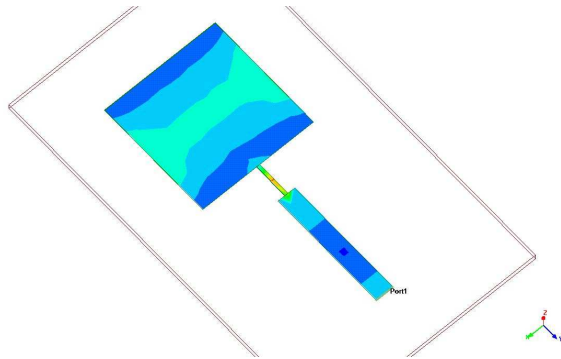

Current distribution on 9.9 GHz simulated patch antenna (more in simulation with Ansoft)

Parameters: RT-Duroid5880 $\epsilon_r = 2.2$ (in mm): $h = 0.508$, $w_{line1} = 1.5$,
 $w_{line2} = 0.27$, $l_{line1} = 2.9$, $w_{patch} = 10$, $l_{patch} = 10$

Micro-strip Patch Antenna IV

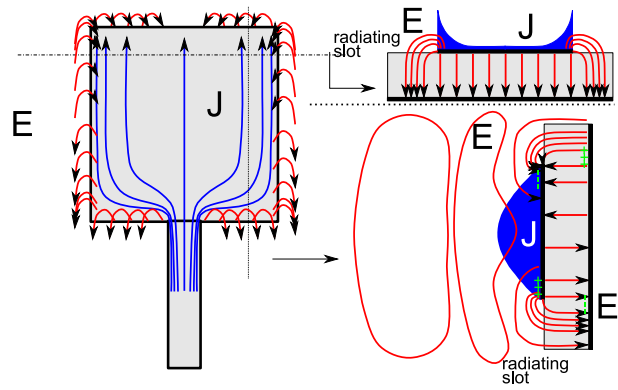

- Current density highest at edges (as in normal micro-strip transmission line)
- Radiation of electrical field along the edges (through slot)
- Field polarized as determined by the excited mode

MS-Patch Rough Design Considerations

RF Basics

System
Overview

Fields &
Waves

Transmission
Lines

Practical TL

2-Port and
S-Parameters

Matching

Antennas

Maxwell's Equations

Antenna Parameters

Linear Antennas

Wave Propagation

Phased Arrays

Yagi Uda

Planar Antennas

- Resonance & bandwidth: Narrow band device, tolerances important
- Matching with usual methods (e.g. quarter-wave line, stubs)
- Correct mode (polarization and radiation pattern)
- Size depends on $\lambda/2$ and dielectric. Higher dielectric \rightarrow smaller size \rightarrow field more confined under patch in dielectric \rightarrow efficiency decreases
- Coupling to other elements (in array) or finite extend of ground plane

Patch Results: In Colors

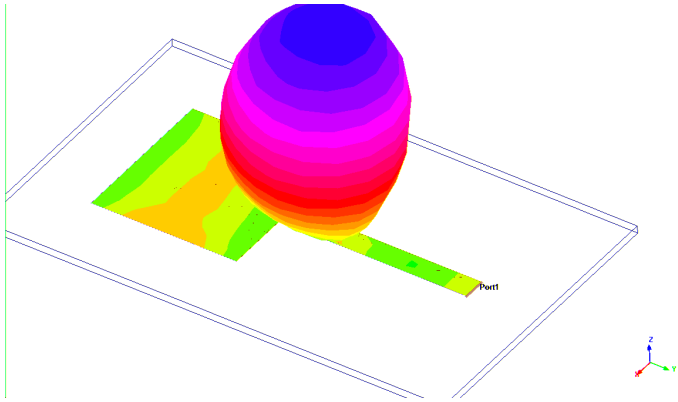

3D-view of the far field and generating current

Patch Results: Match

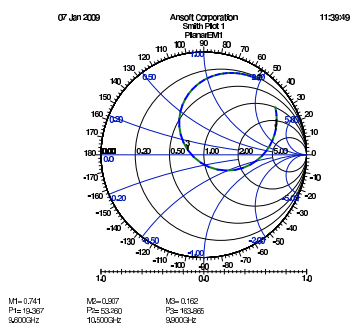

(a)

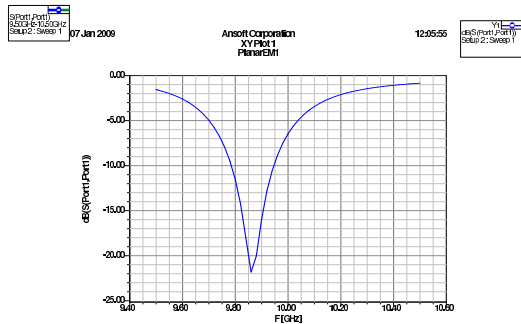

(b)

Impedance (a) in Smith Diagram and (b) reflection from micro-strip patch element.

Patch Results: Field

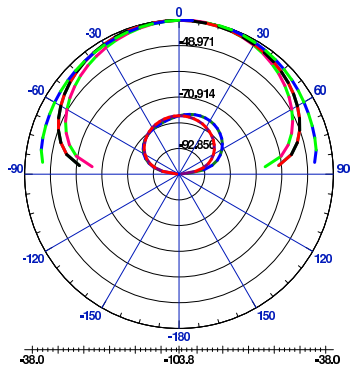

(a)

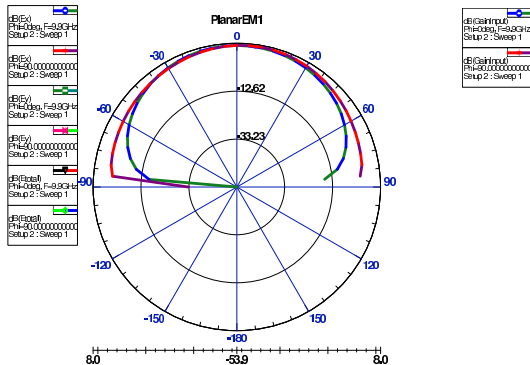

(b)

Electrical field (a) and overall gain (b) from micro-strip patch element.

Patch Results: Gain

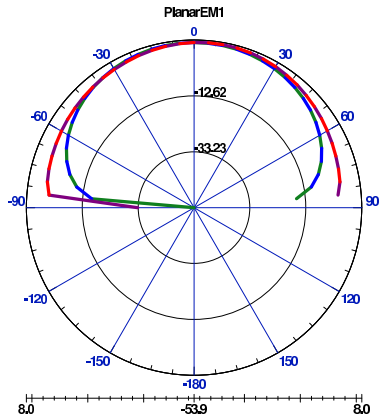

Gain vs. frequency of the patch antenna

Model of MS Patch

- Patch described as a cavity (resonating cavity is below the patch) with
 - Magnetic walls at the (normally radiating) edges
⇒ Perfectly open, but non-radiating (that's what is the simplification)
 - Electric walls as patch and ground (perfectly conducting)
- When dielectric is thin ($h \ll \lambda\sqrt{\epsilon_r}$) then only modes on the patch in x-y direction
- Solution of Maxwell's equation (within these boundaries) yields the modes (not done in all beauty here)
- Electrical field under the patch is thus $E_z = E_0 \cos(m\pi x/l) \cos(n\pi y/l)$,
 $n, m = 0, 1, 2 \dots$

Model of the MS Patch II

- Dominant mode for $m = 1, n = 0$ TM_{10} , again resonance frequency is

$$f_c \approx \frac{c}{2L\sqrt{\epsilon_r}}$$

- Further modes (or a wanted mode distribution) can be done via
 - Different feeds (at two sides or coax at specific location)
 - (Slightly) modify patch (e.g. slots or cut the edges)
- Excitation of further modes used to determine radiation characteristic
 - ① Polarization characteristics
 - ② Circular polarization

MS Patch for Circular Polarization

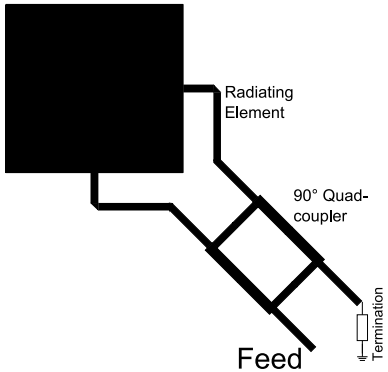

- Micro strip patch antenna for circular polarization with dual feed
- MS-quadrature hybrid used to 90°-phase-shift the signals
- Single feed CP patch antennas also available, eventually simpler in design

Microstrip Array Antennas

- RF Basics
- System Overview
- Fields & Waves
- Transmission Lines
- Practical TL
- 2-Port and S-Parameters
- Matching
- Antennas
 - Maxwell's Equations
 - Antenna Parameters
 - Linear Antennas
 - Wave Propagation
 - Phased Arrays
 - Yagi Uda
 - Planar Antennas

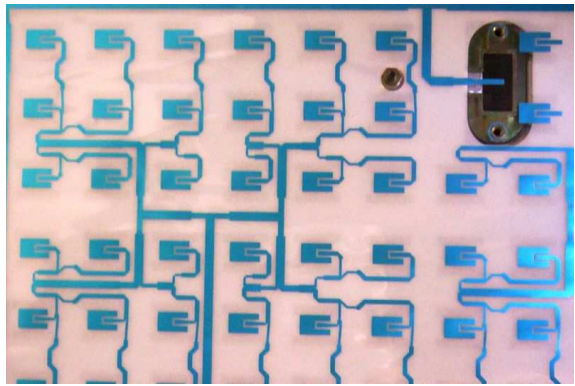

Picture of "ulfbastel", GPL, <http://de.wikipedia.org>

- Micro-strip patches well suited for array applications (RF automotive radar, high gain antennae)
- Simple integration possible

Current and Coupling on MS-Patch Array

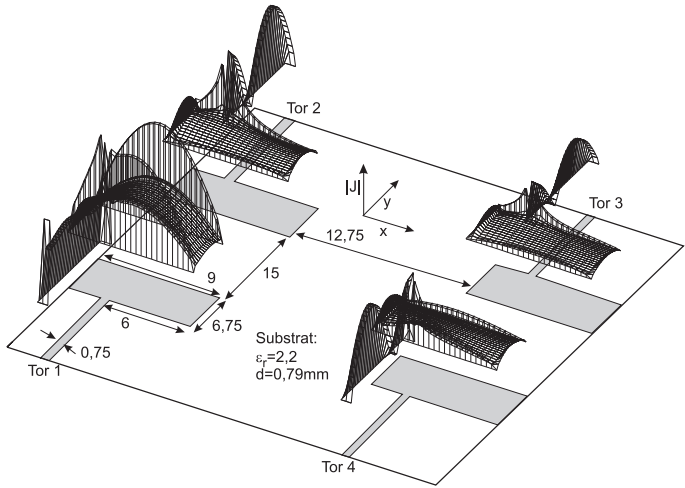

Example after [12] of a micro-strip patch array $f = 10.6\text{ GHz}$. Patch 1 fed, current on 2-4 scaled by 10.

Even More on Printed Antennas

And there is so much more to know about these antennas

- Other than rectangular elements ([log] spirals, circular, ellipsoids) for larger bandwidth and different radiation patterns (polarization)
- Self-complementing antennas (Babinet's principle)
- Modified structures such as slots in the patch (or other geometric structures)
- Stacked patches (for higher band-width)

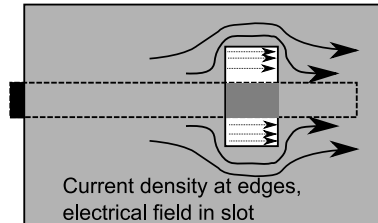

- Slot antennas (i.e. slot in ground plane)
- Respective aperture couple patch antennas (where through the slot a usual patch is excited)

- RF Basics
- System Overview
- Fields & Waves
- Transmission Lines
- Practical TL
- 2-Port and S-Parameters
- Matching
- Antennas
 - Maxwell's Equations
 - Antenna Parameters
 - Linear Antennas
 - Wave Propagation
 - Phased Arrays
 - Yagi Uda
 - Planar Antennas

8 Antennas

- Maxwell's Equations
- Antenna Parameters
- Linear Antennas
- Wave Propagation
- Phased Arrays
- Yagi Uda
- Planar Antennas
- **Small Antennas**
- Mobile Antennas
- Examples in Mobile Phones
- Aperture Antennas
- Reflector

Small Antennas

Wouldn't it be nice to have an antenna of no physical extend (or at least well integrated on a chip)?

- Goal for antennas is to have a moderately high radiation resistance
- ⇒ Low Q (Quality factor) is desired but not by means of losses to the network! [2]
- Fundamental limit $Q \approx \frac{1}{kr}$ for $kr = \frac{2\pi}{\lambda}r \ll 1$ r radius of enclosing sphere
 - Even this has never been reached or exceeded

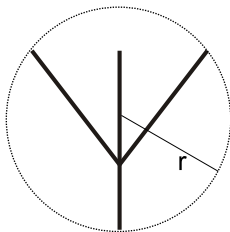

Small Antenna Limits

Consequences on the limit to small antennas

- High Q = high reactive part = low (radiation) resistive part
- Difficult to match (need to compensate reactance, and increase to resistive level of driver/ receiver)
- $Q = \Delta f / f$ so low band-width
- Conductor losses are still there: Small antenna with low input resistance have low efficiency!
- Bottom-line: No matter what: Effective Antennas will have some size! [at best they even resonate]

Shrinking Dipole

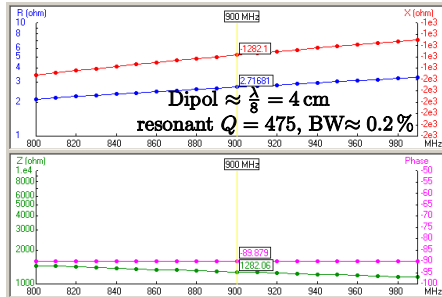
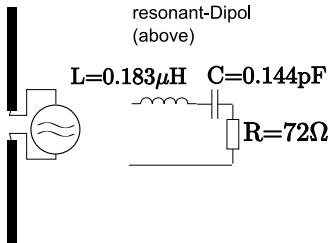
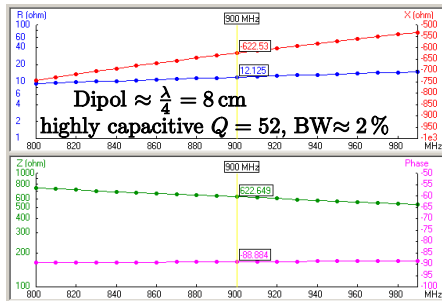
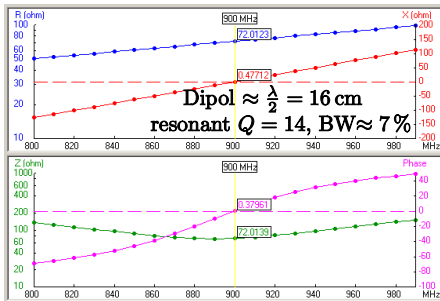

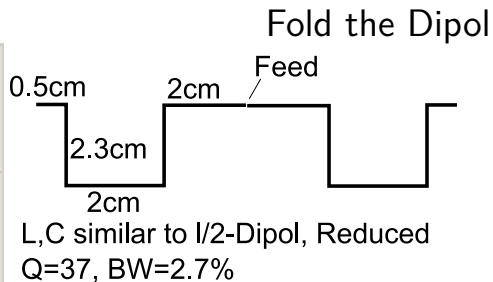
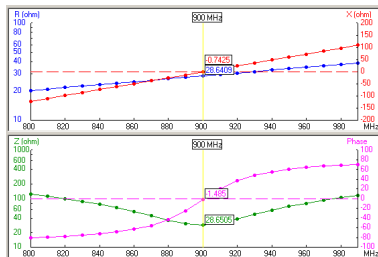

- Folding the Dipol retains the electrical lengths and resonance by reducing extend (9 cm compared to 16 cm)
 - But adds currents in opposite directions (fields cancel)
 - Adds inductance (through bends) and capacitance (through couplings)
- ⇒ Somewhat more compact than the linear dipol, but
- Performance inbetween smaller and resonant dipol (even though this thing is at resonance)

Antennas at DHBW in Karlsruhe

- RF Basics
- System Overview
- Fields & Waves
- Transmission Lines
- Practical TL
- 2-Port and S-Parameters
- Matching
- Antennas
 - Maxwell's Equations
 - Antenna Parameters
 - Linear Antennas
 - Wave Propagation
 - Phased Arrays
 - Yagi Uda
 - Planar Antennas
- Examples in Mobile

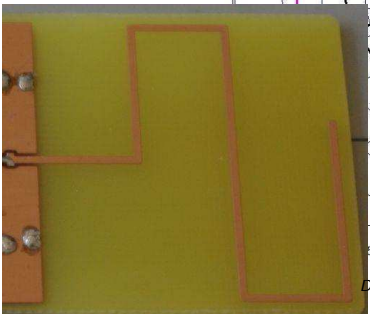
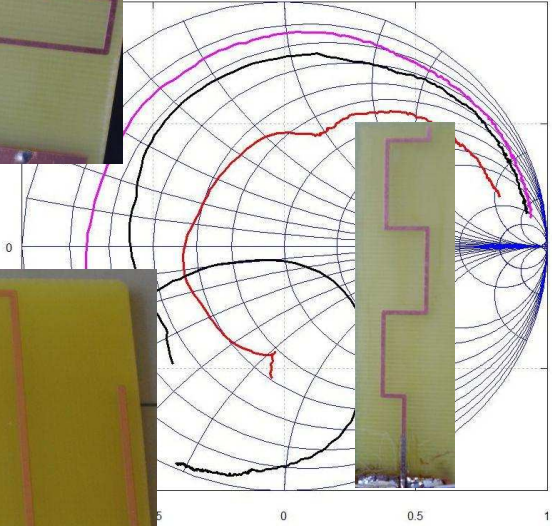
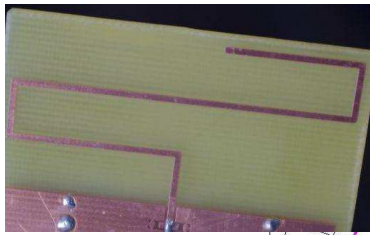

Inverted F-Antenna

Small and somewhat more broadband.

inverted_f_out 1100 MHz

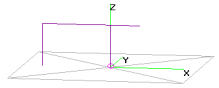

Theta : 90 Axis : 0.05 mtr Phi : 280

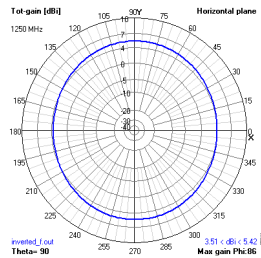
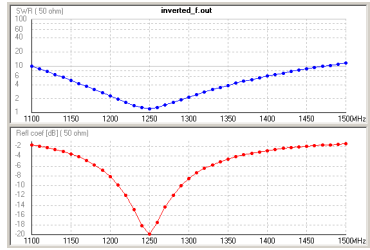
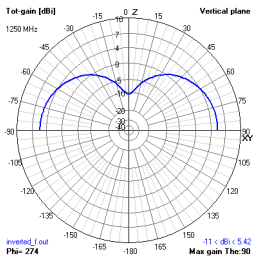

Inverted F-Antenna

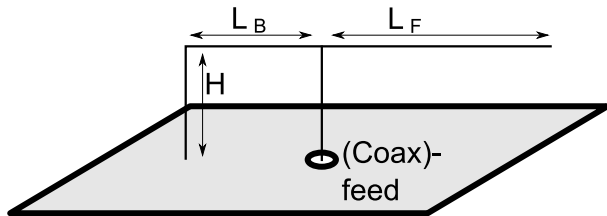

- More on the design is found in [16]
- Height H determines input impedance ($0.1 \dots 0.11 \cdot \lambda$ for 50Ω)
- Parameters for a.m. IFA:

f, λ	1250 MHz	239 mm	H	33 mm	0.138λ
L_B	46.5 mm	0.195λ	L_F	20 mm	0.084λ

Comments on Inverted F-Antenna

- Function:
 - In effect the IFA is a monopole-antenna ($\lambda/4$ -antenna over conducting ground)
 - Folded down (L_F) (to reduce height of the antenna)
 - Folding, and then parallel to ground adds capacitance
 - Compensation of this capacitance done by short stub (L_B) (i.e. inductance)
- Application
 - Popular in cellular phones
 - Can be printed (micro-strip technology), then Planar Inverted F-Antenna (PIFA)

8 Antennas

- Maxwell's Equations
- Antenna Parameters
- Linear Antennas
- Wave Propagation
- Phased Arrays
- Yagi Uda
- Planar Antennas
- Small Antennas
- **Mobile Antennas**
- Examples in Mobile Phones
- Aperture Antennas
- Reflector

Antenna Design for Mobile Communication

Some Design requirements

- Small in size, fitting into design (marketing)
- Small in price, easy to manufacture
- Effective, good SAR (specific absorption ratio) (= do not radiate into the brain!)
- Work in vicinity of head, hand, housing, battery
- Multi-band ...or broadband
 - GSM (824-894, 890-960, 1710-1880, 1850-1990 MHz) and more
 - UMTS (1900-2170 MHz) and growing (see also GSM)
 - WLAN/ WPAN (2400-2485, 5150-5350, 5725-5875 MHz)
 - GPS (1575 MHz) (RHCP)
 - Video (DVB-T, -H) (170-230, 470-862, 1452-1492 MHz)
- Multiple-Antennas: Diversity and MIMO [Multi-In-Multi-Out]

General Concepts

- Combination of above "tricks"
- Loading (parasitic elements)
- Reducing physical size (folding/ meandering)
- Combining many antennas (for same or different task)
- Printed technology, LTCC-technology (chip antennas)

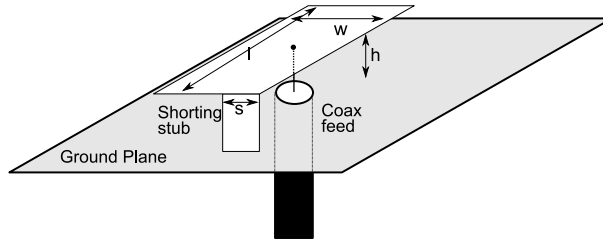

Geometry of a Planar Inverted F-Antenna [5, 13]

- More degrees of freedom: $(L/W), (W/S)$ compared to IFA
- Resonance at $f_{res} \approx \frac{c}{4(w+l+\gamma h)}$
 γ determines influence of grounding strip ($\gamma = 1$ for $s \ll w$, 0 otherwise)
- s Large, bandwidth large (up to 10%), s small BW down to 1%
- Modifications to put slots in the radiating element will meander the current, thus increasing electrical length

Meandered Patch

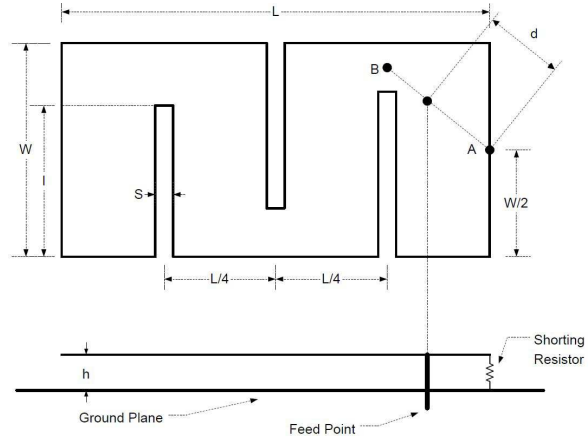

After [5]

Combining PIFA, PIFA, and IFA

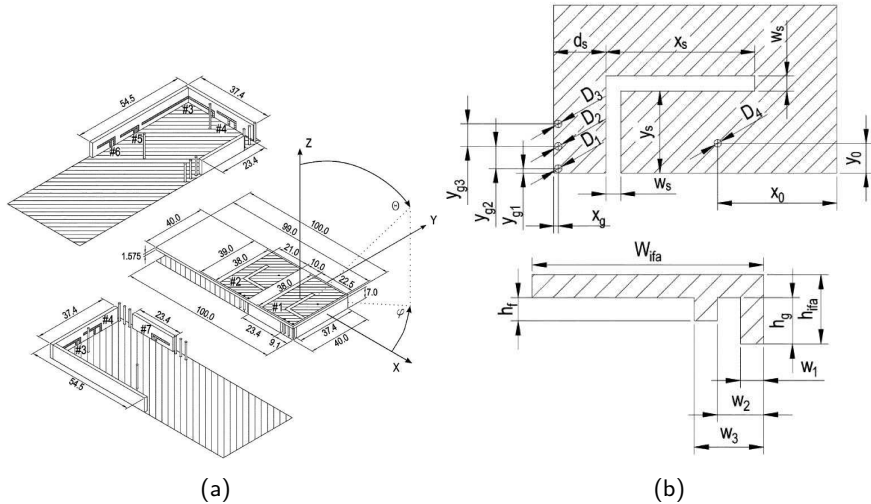

After [7, 9]

Examples in Mobile Phones

8 Antennas

- Maxwell's Equations
- Antenna Parameters
- Linear Antennas
- Wave Propagation
- Phased Arrays
- Yagi Uda
- Planar Antennas
- Small Antennas
- Mobile Antennas
- **Examples in Mobile Phones**
- Aperture Antennas
- Reflector

Examples of Antennas in Mobile Phones

Siemens C35

GSM Helix
Antenna

and
Bluetooth IFA



Examples of Antennas in Mobile Phones

Blackberry 7130,
Multiband printed Antenna
and
Bluetooth

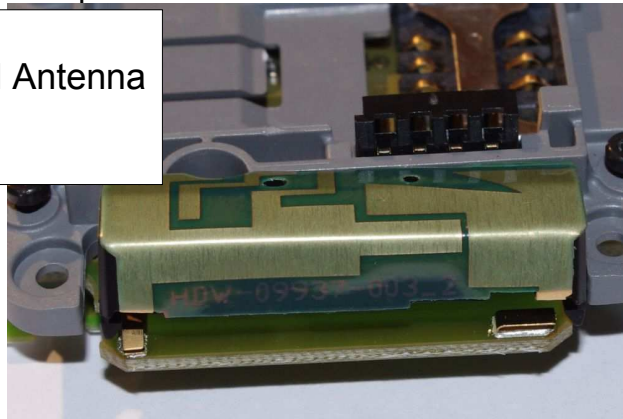
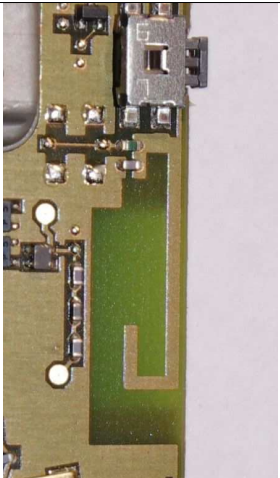

Examples of Antennas in Mobile Phones



Motorola Wire Antenna (left) and
Wirelike HTC TRIN100 Antenna
Battery



Examples of Antennas in Mobile Phones Bluetooth, WiFi, GPS

Apple

iPhone 4

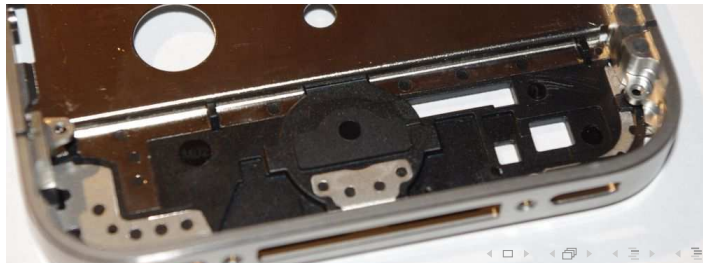
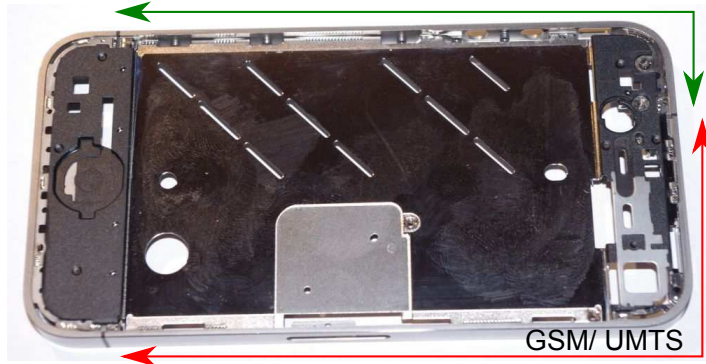

- RF Basics
- System Overview
- Fields & Waves
- Transmission Lines
- Practical TL
- 2-Port and S-Parameters
- Matching
- Antennas
 - Maxwell's Equations
 - Antenna Parameters
 - Linear Antennas
 - Wave Propagation
 - Phased Arrays
 - Yagi Uda
 - Planar Antennas

- 8 Antennas
 - Maxwell's Equations
 - Antenna Parameters
 - Linear Antennas
 - Wave Propagation
 - Phased Arrays
 - Yagi Uda
 - Planar Antennas
 - Small Antennas
 - Mobile Antennas
 - Examples in Mobile Phones
 - Aperture Antennas**
 - Reflector

Aperture Antennas

- "Aperture" = Opening
- What is meant by "Aperture-Antenna" is an antenna that radiates through an opening of something (chapter close to [17]). Examples are
 - Radiation through a hole in a screen
 - Radiation through a (tapered) end of a hollow waveguide (horn antenna)

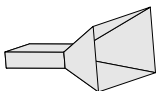

- In Optics: Radiation from the end of a fiber or the laser
- Note one (weird sounding) thing:
 - Energy transport does **not** happen in the conductor through current
 - Energy is transported within the medium (maybe air) between the conductors
 - Wires (also our power cables) are only the guiding elements for the energy carrying fields

Huygens' Principle

Christiaan Huygens (The Netherlands, The Hague 1629 to 1695) stating: "Each point of a (propagating) wavefront can be seen as the source of a new (infinitesimally) elementary wave"

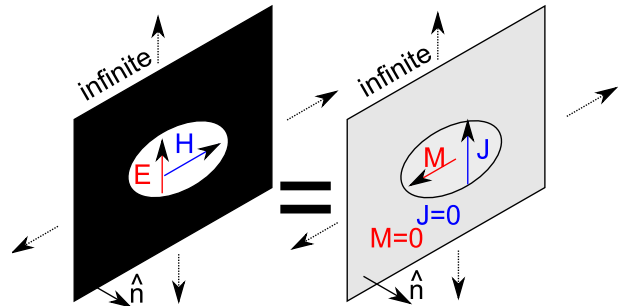

Black material: Electric and magnetic ideal conductor forcing tangential fields of E and H to zero. (For only electrically conducting material $J_S \neq 0$)

Huygens' Principle

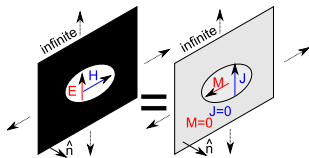

- With a little more formalism this means
 - Know the fields (E, H) (hopefully zero at most locations) on a closed surface
 - The field distribution can be replaced by a set of sources like: Surface current $\vec{J} = \hat{n} \times \vec{H}$ and surface magnetic current $\vec{M} = \hat{n} \times \vec{E}$
 - Now forget about everything, which is within the sphere (or in picture above) behind the infinite wall
- Way: Field distribution $E, H \rightarrow$ Source distribution $J, M \rightarrow$ use of Green's function: (Far) Field distribution of radiation.

Simple Horn Antenna I

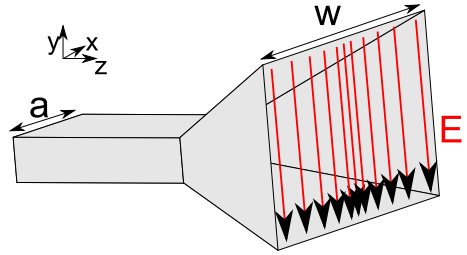

- Impedance of fundamental mode in waveguide $Z_w = \frac{Z_0}{\sqrt{1 - (\frac{\lambda}{2a})^2}}$
- Must be matched to impedance of free space $Z_0 = 120\pi \Omega \approx 377\Omega$

Simple Horn Antenna II

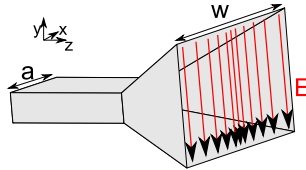

- Done by a taper (suppose that even in the horn only the fundamental mode is present). Impedance at the horn's end $Z_H = \frac{Z_0}{\sqrt{1 - (\frac{\lambda}{2w})^2}}$
- The larger w , the closer Z_H to $Z_0 \rightarrow$
 - Steep horn (danger of multiple mode excitation)
 - Long horn (large and heavy)
 - Geometrical limits for w

Fields in the Waveguide

- For completeness field distribution of fundamental TE_{10} (H_{10}) mode in waveguide and horn (replace a by w) is $E_x = 0$, $E_y = \frac{j\pi\omega\mu H_0}{ak_c^2} \sin \frac{\pi x}{a}$, $E_z = 0$
 $H_x = \frac{j\beta\pi\omega\mu H_0}{ak_c^2} \sin \frac{\pi x}{a}$, $H_y = 0$, $H_z = H_0 \cos \frac{\pi x}{a}$
- All time and z dependent like $e^{-j(\omega t - kz)}$
- Transverse wave-coefficient $k_c = \sqrt{\omega^2 \mu \epsilon - k^2}$

Far Field is Fourier-Transform

- The convenient relation is that the far field distribution (in angular coordinates ϕ, θ) is the Fourier-Transform (over x, y) of the field distribution in the (horn) aperture

The derivation of this statement is cumbersome and of course several assumptions are required. We save all this and state some consequences

- Rectangular distribution (uniform in amplitude, equal phase \rightarrow slow opening of the horn \rightarrow long horn) transforms to $\sin(x)/x \rightarrow$ high side-lobes (E-Plane)
 - E-Plane: Parallel to the electric field. Here, constant field throughout the vertical cut.
 - H-Plane: Parallel to magnetic field, Here, amplitude is tapered according to the \cos distribution \rightarrow lower side-lobes.

Evtl. film or presentation of CST (with permission), or animation

Horn: Practical Example

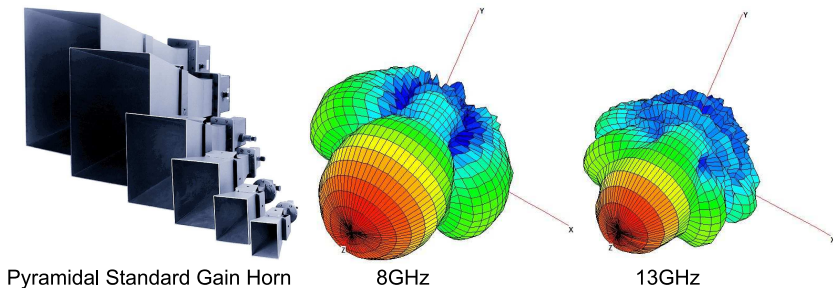

Dimensions: 80.6 mm, 226.3 mm, 62.6 mm

WR90-Dimension: 22,86 mm

Data and figures taken from ETS-Lindgren (Horn3160) <http://www.ets-lindgren.com>

Octave-Band Horn, Practical Data

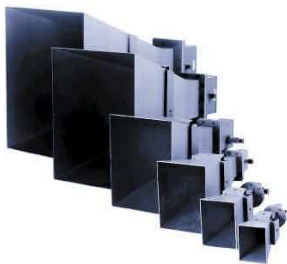

Octave Band Horns

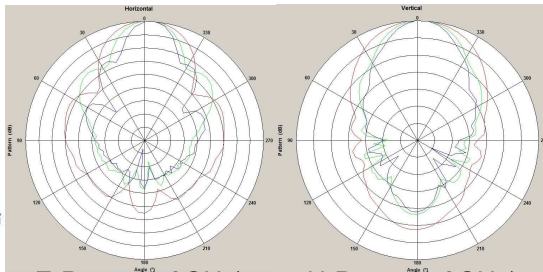

E-Plane (1-2GHz)

H-Plane (1-2GHz)

Dimensions: 531.4 mm, 880.5 mm, 398.6 mm,
WR650-Dimension: 165.1 mm,

Data and figures taken from ETS-Lindgren (Horn3160) <http://www.ets-lindgren.com>

Octave-Band Horn, Practical Data II

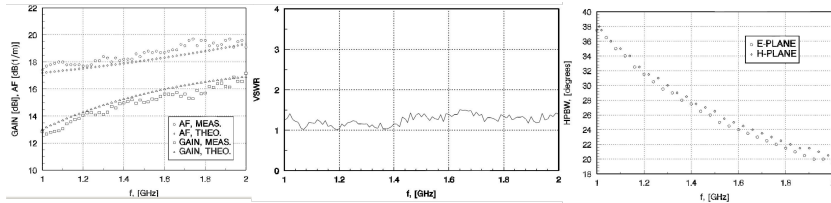

More on the same horn (3161-1), introducing new parameter: antenna factor

Data and figures taken from ETS-Lindgren (Horn3160) <http://www.ets-lindgren.com>

Effective Area

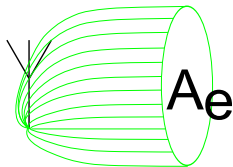

- **Effective Area**
 - For large antennas determined by (\propto) the geometrical size
 - For small antenna can be viewed as the area that the antenna draws the field lines upon itself
- **Effective Aperture (Area)** of an antenna: $A_e = \frac{P_{rec}}{S}$ with (total) power received by a (receiving) antenna P_{rec} and power **density** S at the location of the antenna
- Effective area is proportional to for all antennas and all antenna types
- Relation to gain is calculated to $\frac{A_e}{G} = \frac{\lambda^2}{4\pi}$

More on Aperture Antennas

- Again, almost every thinkable form of aperture has been tried for some purpose
 - Horns, that are bend
 - Circular (conical) horns, or rectangular to circular tapers (the circle is the most efficient aperture form)
- Horns with multiple excited modes for desired aperture illumination
- Corrugated horns for more bandwidth and better radiation characteristic (esp. cross polarization [10, N12.3])
- Slot antennas (Bow-Tie or dual to the dipole)

8 Antennas

- Maxwell's Equations
- Antenna Parameters
- Linear Antennas
- Wave Propagation
- Phased Arrays
- Yagi Uda
- Planar Antennas
- Small Antennas
- Mobile Antennas
- Examples in Mobile Phones
- Aperture Antennas
- Reflector

Reflector Antennas

RF Basics

System
Overview

Fields &
Waves

Transmission
Lines

Practical TL

2-Port and
S-Parameters

Matching

Antennas

Maxwell's Equations

Antenna Parameters

Linear Antennas

Wave Propagation

Phased Arrays

Yagi Uda

Planar Antennas

- Known: The higher the efficient area, the higher the gain: $\frac{A_e}{G} = \frac{\lambda^2}{4\pi}$
- For large antennas ($A_e > \lambda^2$) the effective area is in the range of about the geometrical area
- In this case quasi-optical approaches can be used
- Focusing of radiation with lens or **parabolic mirror**

Parabolic Mirror



Heinrich Hertz Turm in Hamburg

(Photo GPL de wikipedia.org)

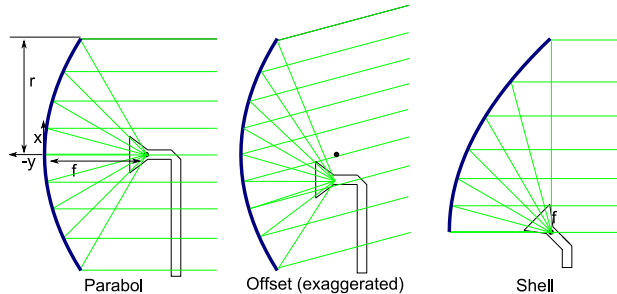

Parabolic mirror, classical approach and feed as in shell antenna

- Description is parabolic with $y = ax^2$
- Focal point $f = 1/(4a)$, where all rays have the same length
- Area (geometric) of course $A_g = \pi r^2$
- And gain is $G = 4\pi \frac{A_e}{\lambda^2} = q \left(\frac{2\pi r}{\lambda} \right)^2$

Parabolic Mirror II

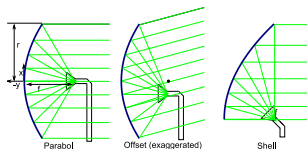

- Area efficiency always < 1 . Determined by
 - Illumination (best: spherical wave with homogeneous illumination of the mirror)
 - Shadowing through mechanical structure and feeding network (horn). \Rightarrow Remedy shell configuration (off-center feed)
- Homogeneous illumination: Higher side-lobes (rect $\rightarrow -14$ dB)
- Backward (off angle) radiation determined by fringing/ diffraction at edges, radiation over the edges, secondary radiation from feeding structure
- Required accuracy of mirror about $\lambda/100 \dots \lambda/50$

Practical Results on Parabolic Mirror

- Gain 30...40 dB
 - HWBW $\Theta_{3dB} \approx 70^\circ \frac{\lambda}{d}$
-
- Simple satellite Dish (Kathrein CAS06), $2r = 0.57 \text{ m}$, $f = 11.7 \dots 12.75 \text{ GHz}$
 $\Rightarrow \lambda \approx 0.027 \text{ m}$ $G = 34.9 \dots 35.9 \text{ dBi}$ $\theta_{3dB} < 2.8^\circ$



- Linear: $G = 3161$ Calculate Area-efficiency $q = G / \left(\frac{2\pi r}{\lambda}\right)^2 = 71\%$

Reflector Antennas Advanced

- Offset Feed
- Folded Mirrors (e.g. Cassegrain-Antenna with Hyperboloid)

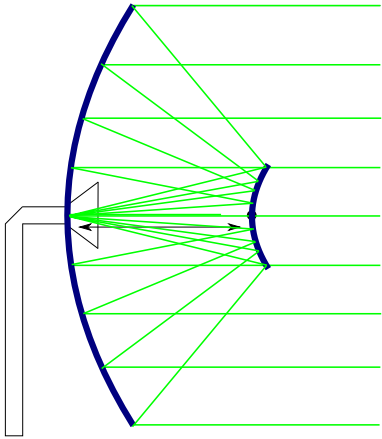

- Polarization and frequency selective reflecting surfaces



Summary

- A walk through antennas:
 - Wire Antennas (short, resonant ($\lambda/2$), long, directional [Yagi-Uda])
 - (Phased) Array Antennas for beam forming and higher directivity
 - Often practically used: IFA and P-IFA
 - Printed antennas: Micro-strip Patch
 - Aperture, (Pyramidal) horn
 - Reflector Antennas
- The tools
 - Analytical (estimation)
 - Method of Moments (NEC and Ansoft HFSS)
 - FDTD/ FIT (Animation and CST)
- Transmission between antennas
- The zoo of Parameters
 - Radiation pattern (Gain, Directivity, Front-Back-Ration, Side-Lobes, aperture angle)
 - Input impedance
 - Parameters (in EMC), (Antenna factors, effective area)
- The principles
 - Maxwell's equation/ wave equation
 - Reciprocity
 - Poynting vector
 - Huygens' principle

References



IEEE Computer Society. *Part 15.4: Wireless Medium Access Control (MAC) and Physical Layer (PHY) Specifications for Low-Rate Wireless Personal Area Networks (WPANs)*. Techn. Ber. 802.15.4. IEEE, 2006.



Constantine A. Balanis. *Antenna Theory, Analysis and Design*. 3. Aufl. New York: Wiley Interscience, 2005.



I. N. Bronstein und K.A. Semendjajew. *Taschenbuch der Mathematik*. 23. Aufl. Leipzig: BSB B.G. Teubner Verlagsgesellschaft, 1987.



R. E. Collin. *Foundations for Microwave Engineering*. 2. Aufl. McGraw Hill, 1991.



N. P. Cummings. "Low Profile Integrated GPS and Cellular Antenna". Magisterarb. Virginia Polytechnic Institute und State University, 2001. URL: <http://scholar.lib.vt.edu/theses/available/etd-11132001-145613/unrestricted/etd.pdf>.



Federal Standard 1037C, Telecommunications: Glossary of Telecommunication Terms. ITS Institute for Telecommunication Sciences. 1996. URL: <http://www.its.bldrdoc.gov/fs-1037/fs-1037c.htm>.



Rafal Glogowski und Custodio Peixeiro. "Multiple Printed Antennas for Integration Into Small Multistandard Handsets". In: *IEEE Antennas and Wireless Propagation Letters 7* (2008), S. 632–635.



N. Kaneda u. a. "A Broad-Band Planar Quasi-Yagi Antenna". In: *IEEE Trans. Antennas Propagat.* 50.8 (Aug. 2002), S. 1158–1160.



D. Manteufel u. a. "Design Consideration for Integrated Mobile Phone Antennas". In: *International Conference on Antennas and Propagation*. Bd. 11. Apr. 2001.



H. Meinke und F.W. Grundlach. *Taschenbuch der Hochfrequenztechnik*. 5. Aufl. Berlin: Springer, 1992.



Numerical Electromagnetics Code. WIKIPEDIA. 2008. URL:

http://en.wikipedia.org/wiki/Numerical%5C_Electromagnetics_Code

Passive Components and Filters

7 Matching

8 Antennas

9 Passive Components and Filters

10 Transistors: Technology, Performance

11 Amplifier: Linear and Design with S-Parameters

12 Noise and Stochastic Processes

- RF Basics
- System Overview
- Fields & Waves
- Transmission Lines
- Practical TL
- 2-Port and S-Parameters
- Matching
- Antennas
- Passives**
- Elements
- Attenuators
- Couplers
- Filters
- Transistors

What you Gain

- Overview about important passive components
- See and learn the difference between realizations
- Narrow-band lossless versus broadband lossy

What Components?

- Resistor, Capacitor, Inductor and inductive coupler
- Attenuators
- Power dividers
- Directional Couplers
- Filters

Some Lumped Elements

9 Passive Components and Filters

- Some Lumped Elements
- Attenuators
- Couplers
- Filters

10 Transistors: Technology, Performance

Wire Above a Conducting Plane

A simple wire of Diameter D , length l in a distance $s \leq l$ above a conducting plane represents an inductance

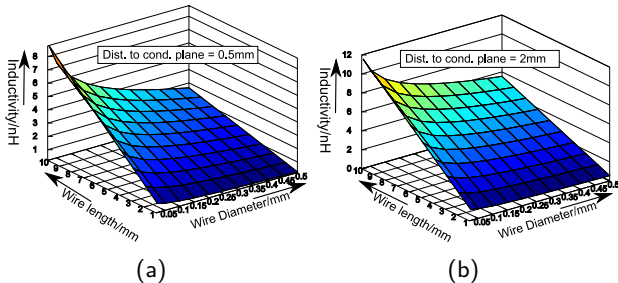

- The formula for this is given by
$$L = \frac{l\mu_0 \ln\left(\frac{2s}{D} + \sqrt{\left(\frac{2s}{D}\right)^2 - 1}\right)}{2\pi}$$
- Comparison between the two pictures shows immediately why THT-technology is not well suited for RF
- Also: Thick wires are better (if wire at all)

Resistor

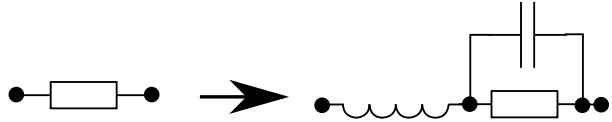

- Inductance mostly from wiring
- Cap from meanders of resistive material
- Note that this structure does not resonate
- At high frequencies this is much, but not a simple ohmic resistor (high here defined as measure how much C and L influence the total value of impedance)
- Total impedance is $Z = j\omega L + \frac{R}{1+j\omega CR}$
- No resonance, but definitely decay in real part of impedance with frequency

Capacitor



Equivalent Circuit for a cap. Observe that this, is a filter circuit that can resonate.

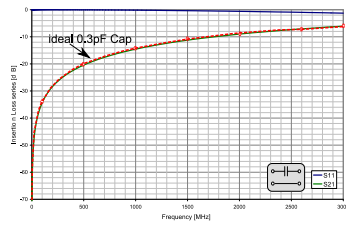

(a)

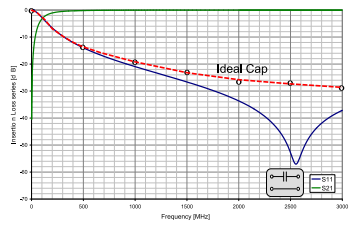

(b)

Real (acc. to EPCOS) behaviour of cap of 0.3 pF and 15pF. How bad is the non-idealism really?

Inductor

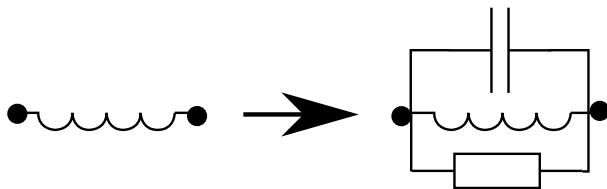

Equivalent Circuit of an inductor

0402 Ind. 1...100nH

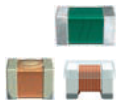

0805 RF-Chokes

Transformer & Baluns

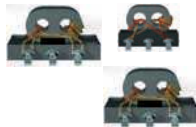

Pictures of some sample devices (not to scale) Note (if only one thing) that there is a parallel

resonant circuit with L parallel C, and thus resonating at $f_{res} = \frac{1}{2\pi\sqrt{LC}}$

Inductor II

Some parameters for inductors as given by vendors (here: EPCOS)

- f_L Measuring frequency of inductor (some 100 MHz)
- f_Q Measuring frequency for quality factor (e.g. 800 or 1500 MHz)
- Q Quality factor (defined here as $Q = \omega L/R$), only about 10 to 50
- f_{res} Resonant frequency range few 100 MHz to 9 GHz, the higher the inductance, the lower f_{res}
- R_{max} DC-resistance, low inductance maybe $\ll 1 \Omega$, high inductance $> 1 \Omega$

Impedance $|Z|$
versus frequency f
measured with impedance analyzer
HP 4191A / HP 4194A

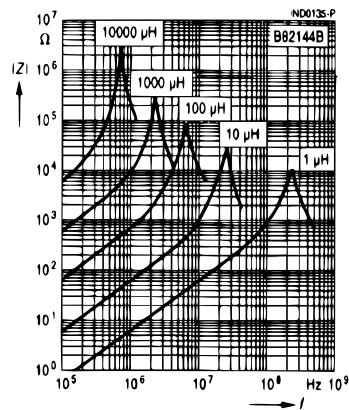

Some Values

Transformer

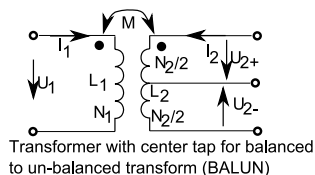
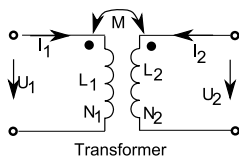

- Two coupled inductances L_1 , L_2 show mutual coupling $M = k\sqrt{L_1L_2}$, $k = 0 \dots 1$
- With close coupling $\frac{U_1}{U_2} = \frac{I_2}{I_1} = \frac{N_1}{N_2} = \frac{1}{N}$ and thus transformation of impedances $R_1 = \frac{U_1}{I_1} = \frac{U_2/N}{I_2/N} = \frac{1}{N^2} \frac{U_2}{I_2}$
- A resistance R_2 on the secondary side (2) is seen as $1/N^2 R_2$ on the primary side. This is used to transform high impedances on the secondary side to a lower level on the primary (e.g. for matching crystals)
- Center tap used for Balanced to unbalanced transformation (e.g. ADC, antennas)
- Practical RF coupling ratio $N^2 = 1 \dots 50$

9 Passive Components and Filters

- Some Lumped Elements
- **Attenuators**
- Couplers
- Filters

10 Transistors: Technology, Performance

Simple Resistive Attenuators

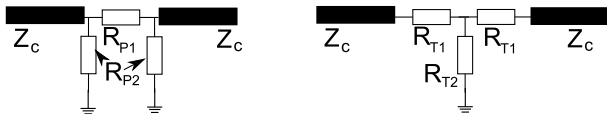

For an attenuation ratio $c = u_2/u_1$ the resistors are to be dimensioned as (equal characteristic impedances Z_c at both sides)

- T-circuit $R_{T1} = \frac{1-c}{1+c} Z_c$, $R_{T2} = \frac{2c}{1-c^2} Z_c$
- Π -circuit calculated from T-model via star-triangular transform:

$$R_{P1} = R_{T1} \frac{2R_{T1} + R_{T2}}{R_{T2}} = R \frac{1-c^2}{2c}$$

$$R_{P2} = R \frac{1+c}{1-c}$$

- Note: There is power to be absorbed in the attenuator, thus thermal issues may occur!
- See next slide for example values

Attenuator: Resistive Values

Resistor values for attenuators at $Z_c = 50\Omega$

Att./ dB	U_1/U_2 (lin)	R_{P1}/Ω	R_{P2}/Ω	R_{T1}/Ω	R_{T2}/Ω
0.25	0.97	1.4	3474.6	0.7	1736.9
0.5	0.94	2.9	1737.7	1.4	868.1
1	0.89	5.8	869.5	2.9	433.3
2	0.79	11.6	436.2	5.7	215.2
3	0.71	17.6	292.4	8.5	141.9
5	0.56	30.4	178.5	14.0	82.2
10	0.32	71.2	96.2	26.0	35.1
20	0.10	247.5	61.1	40.9	10.1
30	0.03	789.8	53.3	46.9	3.2

RF Basics

System
Overview

Fields &
Waves

Transmission
Lines

Practical TL

2-Port and
S-Parameters

Matching

Antennas

Passives

Elements

Attenuators

Couplers

Filters

Transistors

9 Passive Components and Filters

- Some Lumped Elements
- Attenuators
- **Couplers**
- Filters

10 Transistors: Technology, Performance

Resistive (6dB) Power Divider

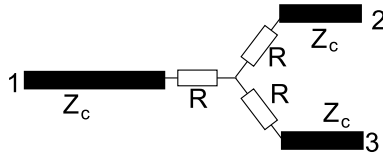

- $R = Z_c/3$
- Only 6 dB dividing ratio, that means half the power is lost in the divider (beware of heating and maximum power delivered to the divider).
- Broadband, only limited by frequency response of resistor and dispersion of line.
- S-Matrix (ideally)

$$\bar{\bar{S}} = \begin{pmatrix} 0 & S_{12} & S_{13} \\ S_{12} & 0 & S_{23} \\ S_{13} & S_{23} & 0 \end{pmatrix}, |S_{23}| = |S_{12}| = |S_{13}| = \frac{1}{2}$$

Wilkinson (Power) Divider

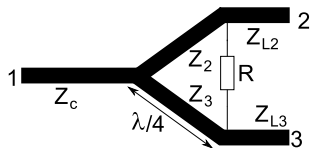

- Goal: Build a lossless power divider, here this requires e.g. $S_{23} = 0$ and $|S_{12}| = |S_{13}| = 1/\sqrt{2}$
- When ideally matched: no power consumed in resistor, in case of mismatch, resistor decouples port 2 and 3.
- Many different designs exist. Equations $Z_2 = K\sqrt{RZ_c}$, $Z_3 = \frac{1}{K}\sqrt{RZ_c}$, $Z_{L2} = \frac{K^2 R}{K^2 + 1}$, $Z_{L3} = \frac{R}{K^2 + 1}$, K coupling factor can be chosen.
- Choose $K = 1$ $Z_{L2} = Z_{L3} = Z_c \Rightarrow R = 2Z_c \Rightarrow Z_2 = Z_3 = \sqrt{2}Z_c$ for a matched equal power divider.

Branch Line (Quadrature) Coupler

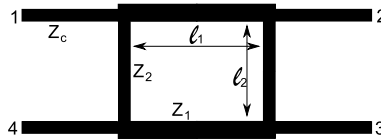

- Dimension $Z_2 = Z_c$, $Z_1 = Z_c/\sqrt{2}$, $l_1 = l_2 = 90^\circ$. Note: Length here electrical length, physical dimension may differ because of different ϵ_{eff} . Length effectively measured to centers of junctions.
- 3dB directional coupling ratio from port 1 (or 4) to ports 1 and 2, port 4 (or port 1) decoupled.
- At decoupled port sum of mismatch of port 2 and 3 is found
- Phase difference between port 2 and 3 is 90° , thus also the name 90° -coupler

Directional Coupler

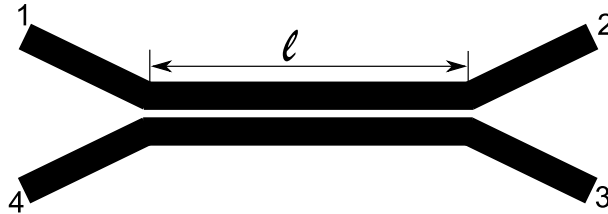

Coupling ratio is determined by

$$C = 20 \log \frac{\sqrt{1 - c^2 \cos^2 \beta l}}{c \sin \beta l}$$

With known maximum coupling ratio (see coupled micro-strip lines) of

$$c = (Z_e - Z_o) / (Z_e + Z_o)$$

Coupling maximum occurs at length $l = \lambda/4$ (quarter wavelength) long, it again vanishes ($C = 0$) at half wavelength $l = \lambda/2$.

Couplers etc. more to Know

- Unequal power power-splitters
- Frequency response adjustment through multi-section coupling and matching
- Multi-arm (evtl. non-binary) splitters
- 180° and Rat-race hybrid rings
- Modifications to directional couplers: The Lange-coupler

- RF Basics
- System Overview
- Fields & Waves
- Transmission Lines
- Practical TL
- 2-Port and S-Parameters
- Matching
- Antennas
- Passives
 - Elements
 - Attenuators
 - Couplers
 - Filters**
- Transistors

9 Passive Components and Filters

- Some Lumped Elements
- Attenuators
- Couplers
- **Filters**

10 Transistors: Technology, Performance

Filters & Resonators

Filters are nothing else than (frequency) selectively matching input an output port. I.e. rejecting certain signals, but transferring others.

Possible technologies are:

Name	f -range/ Hz	Q_u	Application
Lumped	20k-500M	500..20	many
Helical-	100M-1G	200..20	input filter CT1
Ceramics-	200k-30M	2000..500	IF-f. in receivers
Quartz-	40k-80M	$10^4 \dots 10^5$	Radio-watches
SAW-	30M-3G	5000..2000	TV, cellular IF
TRL	100M-10G	200..10	UHF, mm-wave
Ceramic-line	400M-2G	ca. 500	DECT, GSM/ UMTS
FBAR-	2G-3G	5000..2000	cellular, ISM
Dielectric res.	1G-30G	1000..200	μ -wave oscillator
Cavity	2G-30G	1000..20	Radar, high power

Series- and Parallel Resonator

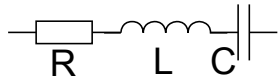

Series

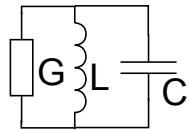

Parallel

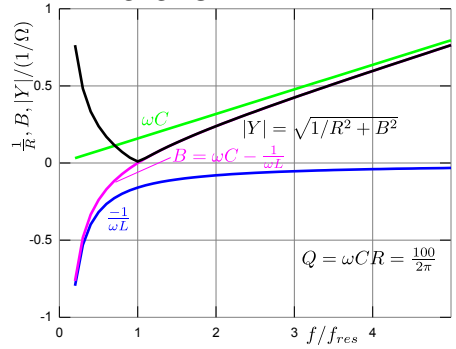
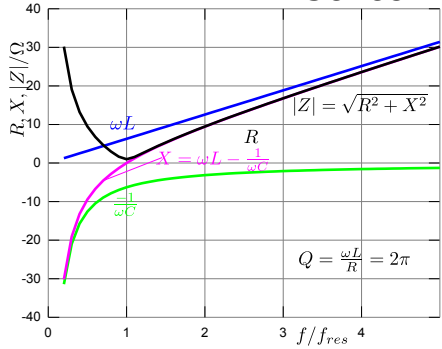

Quality Factor

- Definition of quality factor is $Q = \frac{\text{Power stored in field}}{\text{Power lost in resistor}}$
- Can be equivalently derived to $Q = \frac{f_0}{B}$ with bandwidth $B = f_2 - f_1$ and f_0 the resonance frequency

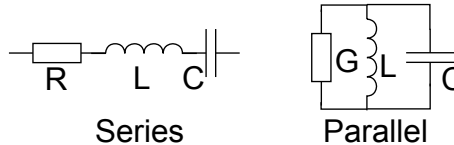

Quality factors for series and parallel resonant circuits

	Series	Parallel
Inductor	$Q = \frac{\omega L}{R}$	$Q = \frac{1}{\omega L G}$
Capacitor	$Q = \frac{1}{\omega C R}$	$Q = \frac{\omega C}{G}$

Lumped Element Resonator

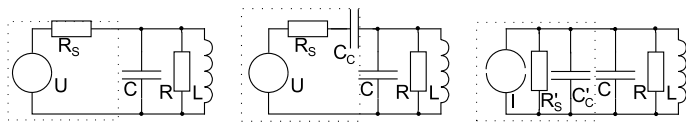

- THE prototype of resonator. Used as equivalent circuit for almost all types of resonators
- Resonant frequency determined by $f = \frac{1}{2\pi\sqrt{LC}}$, i.e. L and C cancel each other.
- Unloaded Quality factor $Q_u = R/(\omega L) = \omega C R$ for parallel resonance!
- Loaded Quality factor $Q_L = \omega C (R || R_s)$ factors inner resistance of source in.
- For $R_s = 50\Omega$ loaded Q_L very bad. Thus, different couplings required (e.g. with cap C_c)
 \Rightarrow if C_c chosen small enough, R'_s get very high and presents much smaller load to resonant circuit.

Cavity Resonator I

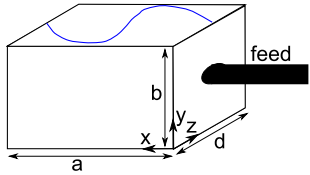

- Basically hollow metallic (often rectangular or spherical) box, that cages the electromagnetic field in.
- For rectangular cavity resonant frequency of modes of order (n,m,l)

$$f_{n,m,l} = \frac{1}{\epsilon_r \epsilon_0 \mu_0} \sqrt{\left(\frac{n}{2a}\right)^2 + \left(\frac{m}{2b}\right)^2 + \left(\frac{l}{2d}\right)^2}$$

- Solution of the field follows boundary conditions at the walls, e.g. for 101-mode

$$k_{101} = \sqrt{\left(\frac{\pi}{a}\right)^2 + \left(\frac{\pi}{d}\right)^2}$$

$$E_y = \frac{-2A^+ k_{101} Z_0 a}{\pi} \sin \frac{\pi x}{a} \sin \frac{\pi z}{d}$$

$$H_x = \frac{2jA^+ a}{d} \sin \frac{\pi x}{a} \cos \frac{\pi z}{d}, \quad H_z = -2jA^+ \cos \frac{\pi x}{a} \sin \frac{\pi z}{d}$$

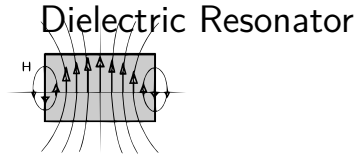
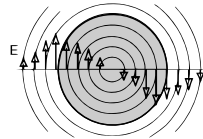

$TE_{01\delta}$ Mode in cylindrical dielectric resonator

- Mostly cylindrical, basically the same as cavity, except, field is en-caged more “loosely” only in high permeability material $\epsilon_r \approx 30 \dots 200$.
- Coupling via field from (micro-strip) line
- Use mostly (but not limited to) μ -wave oscillators \Rightarrow Dielectric Resonator Oscillator.
- Mostly used is $TE_{01\delta}$ Mode, where there is no angular (ϕ), some radial (r) and only a fraction (δ) of z -dependence

More on Dielectric Resonator

- Quality factor is determined by $Q_u = \epsilon'_r / \epsilon''_r$. Common measure is quality factor times measurement frequency $Q_u f_0$ up to $100.000 \cdot 1/s$. (Losses are linear with frequency)
- Approximation for resonance frequency $f_0 \approx \frac{233}{\sqrt{\epsilon'_r} \sqrt[3]{V}}$, with V the volume of the puck
- Example: $\epsilon'_r = 37$, diameter 5.5 mm, height 2.3 mm $f_0 = 10.1$ GHz
- Observe temperature stability τ_f , where frequency drift $(\tau_f f_0 \Delta T) = \Delta f$ with temperature change δT
- Coupling and tuning screw determine exact frequency and quality factor

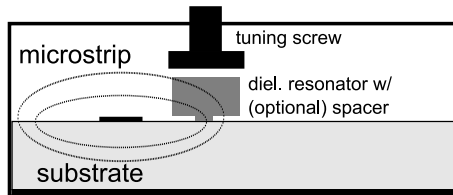

Model of the Resonator

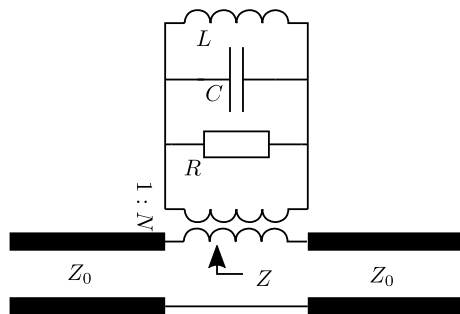

Z as seen by the MS is

$$Z = \frac{N^2 R}{1 + j2Q\Delta\omega/\omega_0} \quad \text{with}$$
$$Q = \frac{R}{\omega_0 L} \quad \omega_0 = \frac{1}{\sqrt{LC}}$$
$$\Gamma_{res} = \frac{(Z_0 + N^2 R) - Z_0}{(Z_0 + N^2 R) + Z_0} = \frac{N^2 R}{2Z_0 + N^2 R}$$

Model of the Resonator

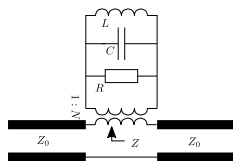

When Γ has been chosen,

$$\frac{N^2 R}{2Z_0} Z = g = \frac{\Gamma}{1 + \Gamma}$$

called coupling factor of resonator is found. It leaves degree of freedom, since only $N^2 R = 2Z_0 \Gamma / (1 + \Gamma)$ is determined

Surface Acoustic Wave Filters

Excite (electrically) an acoustic wave on the surface of a (piezo) crystal and (re)detect it

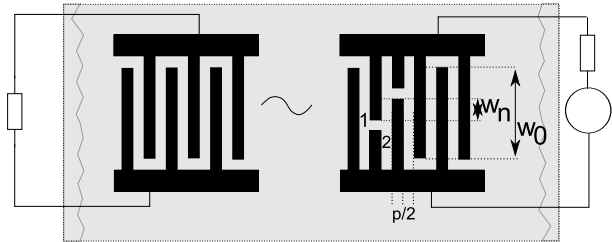

Structure of SAW-filter

- Important element: Transducer (inter-digital structure) with electrical field between the fingers \Rightarrow contraction, extraction of piezo-material \Rightarrow ignites wave.

Surface Acoustic Wave Filters II

- With electrical pulse excitation a SAW-pulse (δ)-pulse is generated. Multi fingers, thus have frequency response of

$$H(f) = \sum_{n=1}^N (-1)^n \frac{w_n}{w_0} e^{-j2\pi f n p v}$$

where: n is number of finger, determining also polarity, N total number, w_n/w_0 finger overlap (relative), p periodicity and v velocity of the wave.

- Total frequency response has shape of $\sin x/x$, center frequency $f_0 = v/(2p)$ and 4 dB bandwidth $B = 2f_0/B$





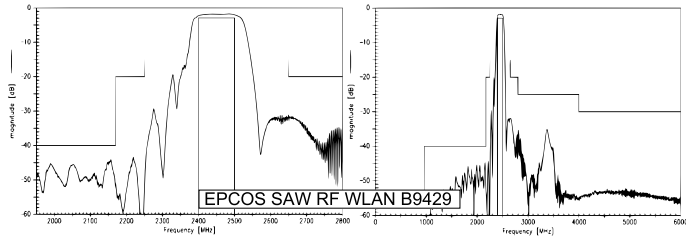

SAW-Filters: Practical Issues

- Poor grounding (inductance to ground because of via holes) yields high cross talk → minimize inductance to ground, use multiple via holes
- Usage as IF-filters (almost everywhere) and RF-filters (2.5 GHz no problem), low power (typ. <30 dBm)
- Passband insertion loss 2..3 dB, stop-band rejection typ. 30dB
- Matching (possible with LC) typically required to get to 50 Ω check data-sheet for typical impedances!



- RF Basics
- System Overview
- Fields & Waves
- Transmission Lines
- Practical TL
- 2-Port and S-Parameters
- Matching
- Antennas
- Passives
 - Elements
 - Attenuators
 - Couplers
 - Filters**
- Transistors

Film Bulk Acoustic Resonators

-  High Q, low loss, sharp transition
-  Good power handling
-  Not ESD sensitive
-  RF integration possible (small, on silicon)
-  Costly
-  Only available for huge markets/ volumes

FBAR-Filter

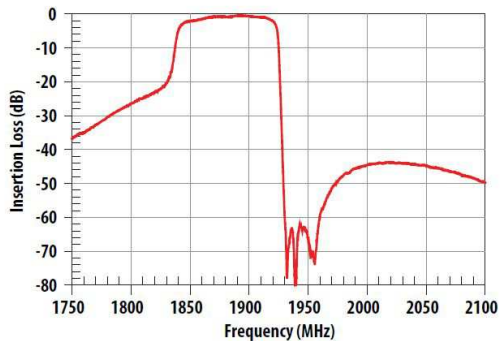

(a)

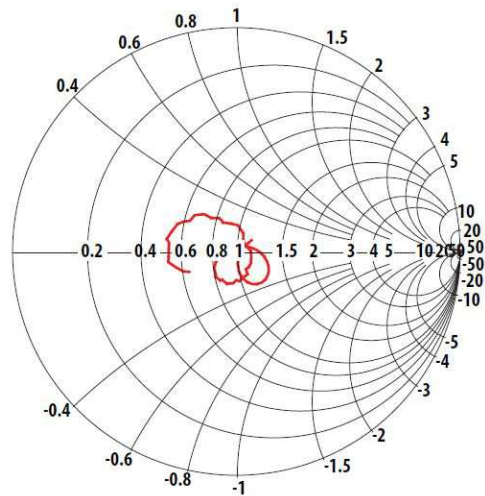

(b)

(a) Transmission of Avago FBAR-filter ACPF-7500 (UMTS Band II Tx), (b) S_{11} in Smith-Chart.

Filter needed for

- RF-RX: RF selection (reject blockers, limit bandwidth, thus minimize noise bandwidth)
- RF-TX: Keep spectrum clean, do not disturb others! Shape spectrum.
- IF: Separate wanted and unwanted signal (e.g. LO rejection), reject image frequencies

Filter development

- Systematic approach to design frequency response
- Translate from prototype (low-pass) filters wanted shape (e.g. bandpass)
- Translate into physical structures. Here: transmission-lines

Prototype-Filters

- Starting point: Power-Loss-Ratio $P_{LR} = \frac{1}{1-\rho^2} = \frac{1}{1-\Gamma\Gamma^*}$
- Express with well defined ratio of polynomials: $P_{LR} = 1 + \frac{M(\omega^2)}{N(\omega^2)}$
- Butterworth-filter for $N(\omega^2) = 1$ and $M(\omega^2) = k^2(\omega/\omega_c)^{2N}$
- Chebyshev-filter for $N(\omega^2) = 1$ and $M(\omega^2) = k^2 T_N^2(\omega/\omega_c)$ for Chebyshev-characteristic. T_N : Chebyshev-Polynomial order N

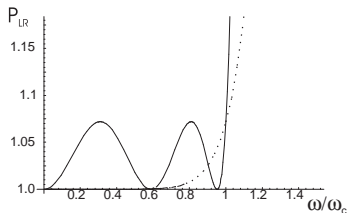

Characteristics for
Butterworth- (---)
und Chebyshev-low-pass
(—) order 5

Prototype Filter Characteristics

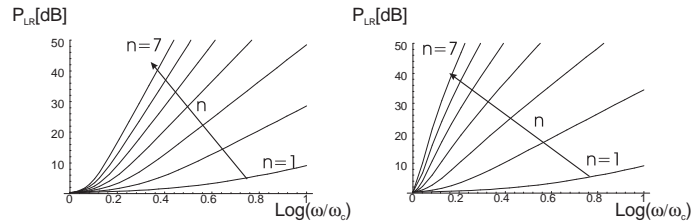

(a) Butterworth, (b) Chebycheff.

Rejection-characteristics for different order filters ripple $\rho_{max} = 1$ dB. (a) Butterworth, (b) Chebycheff.

- Chebycheff:
 - Highest possible (polynomial) selection
 - Ripples in pass-band
- Butterworth:
 - Maximum flat in passband
 - Fairly low rejection

Filter Prototype Structure

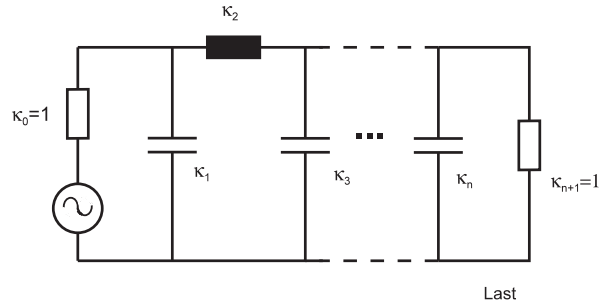

Low-pass prototype, starting with cap.

- RF Basics
- System Overview
- Fields & Waves
- Transmission Lines
- Practical TL
- 2-Port and S-Parameters
- Matching
- Antennas
- Passives
- Elements
- Attenuators
- Couplers
- Filters**
- Transistors

Element Values: Butterworth

n	1	2	3	4	5	6	7
κ_1	2	1.4142	1	0.7654	0.6180	0.5176	0.4450
κ_2	1	1.4142	2	1.8478	1.6180	1.4142	1.2470
κ_3		1	1	1.8478	2	1.9319	1.8019
κ_4			1	0.7654	1.6180	1.9319	2
κ_5				1	0.6180	1.4142	1.8019
κ_6					1	0.5176	1.2470
κ_7						1	0.4450
κ_8							1

Prototype Elements for Butterworth filter

- All orders terminate in 1 \Rightarrow All orders lead to matched filter
- Elements calculated with $L_k = \frac{\kappa_k Z_0}{\omega}$ and $C_k = \frac{\kappa_k}{\omega Z_0}$
- ω is 3 dB corner frequency, Z_0 impedance level (here: 50Ω)

Element Values: Chebycheff

n	1	2	3	4	5	6	7
κ_1	1.018	1.822	2.024	2.099	2.135	2.155	2.166
κ_2	1	0.685	0.994	1.064	1.091	1.104	1.112
κ_3		2.660	2.024	2.831	3.001	3.063	3.093
κ_4			1	0.789	1.091	1.152	1.174
κ_5				2.660	2.135	2.937	3.093
κ_6					1	0.810	1.112
κ_7						2.660	2.166
κ_8							1

Table of prototype values for Chebycheff low-pass with $\rho_{max} = 1$ dB

- Only odd orders terminate in 1, thus only they can be matched to 50Ω

Recipe for Low-Pass-Filter

- ① Select corner frequencies ω , maximum loss (ripple) ρ_{max} in pass-band, selectivity
- ② Selection of maximum ripple determines which table (from elaborate literature) to use. Standard values for ρ_{max} are usually tabulated
- ③ Selectivity requirements determine order. Evtl. use graphics for this
- ④ Take prototype (normalized) values κ_n
- ⑤ Carry values over to physical network with $L_k = \frac{\kappa_k Z_0}{\omega}$ and $C_k = \frac{\kappa_k}{\omega Z_0}$
- ⑥ If transmission line-design wanted, use formulae for short lines and calculate length $l_L = \frac{\lambda_L}{2\pi} \arcsin(\omega C Z_L)$ for low impedance (L) and $l_H = \frac{\lambda_H}{2\pi} \arcsin\left(\frac{\omega L}{Z_H}\right)$ for high impedance (H) section.

Example: Low-Pass in Micro-strip Technology

Design requirements

- Butterworth, order ≥ 5 (we will chose 7)
- Low-pass up to 1 GHz, high rejection for $f \approx 10$ GHz
- Design for 50Ω in microstrip-technology, on RT-Duroid 5880, $\epsilon_r = 2.2$, $h=0.508$ mm
- Chose impedances (should be manufacturable, only supporting one mode and still as far apart as possible),
 $Z_H = 120 \Omega$, $w_H = 0.27$ mm;
 $Z_L = 15 \Omega$, $w_L = 7.3$ mm
- Compensation done empirically (just scale length of lines)

Element Parameters

Element	Value	el. l uncomp.	phys.l/mm comp.
C_1	1.4 pF	7.7°	3.6
L_1	9.9 nH	31°	16.4
C_2	5.7 pF	33°	15.6
L_2	16 nH	56°	29.6
C_3	5.7 pF	33°	15.6
L_3	9.9 nH	31°	16.6
C_4	1.4 pF	7.7°	3.6

Low-pass-Filter Layout

RF Basics

System
Overview

Fields &
Waves

Transmission
Lines

Practical TL

2-Port and
S-Parameters

Matching

Antennas

Passives

Elements

Attenuators

Couplers

Filters

Transistors

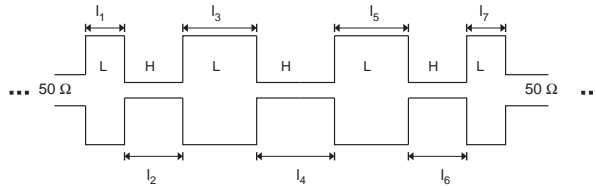

Micro-strip-layout of a Butterworth low-pass.

Low-Pass-results

09 Dec 2008

Ansoft Corporation
XY Plot 2
Circuit1

13:11:12

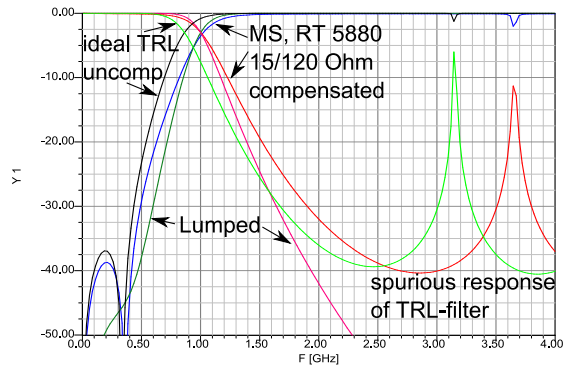

Realization in Coax-Technology

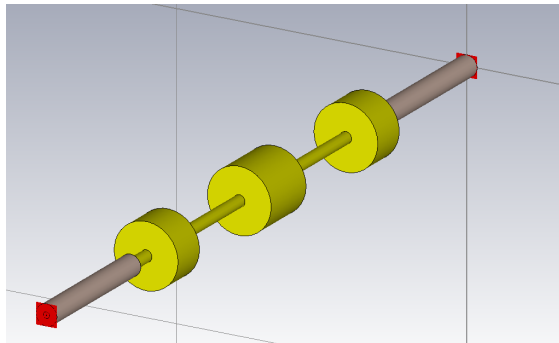

(a)

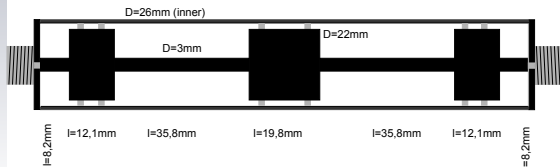

(b)

Inner conductor (a) and dimension (b) with outer conductor 26mm for coaxial low-pass-filter.

Coax-Low-Pass-Filter (Results)

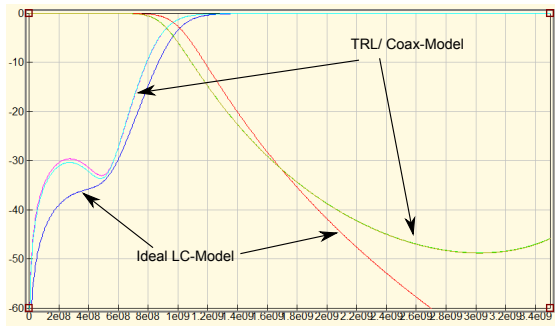

(a)

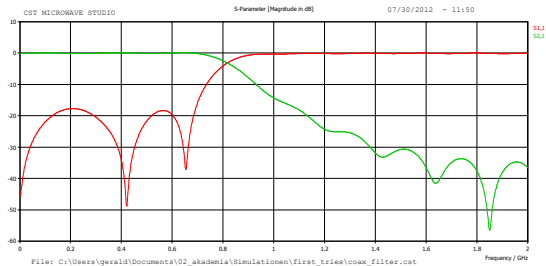

(b)

Simulation with effective ideal LC, TRL and Coax-TRL Models (a) and full wave simulation with CST (b).

Modes in Coax-Filter

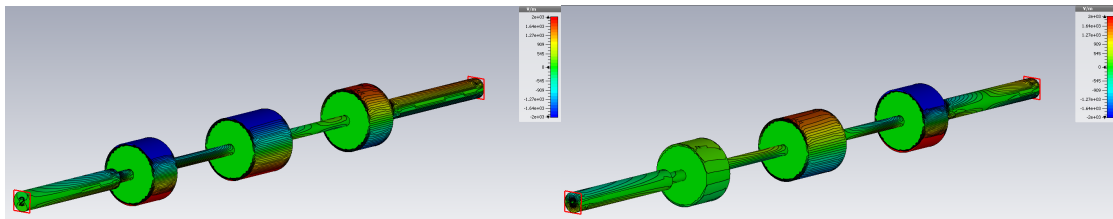

(a)

(b)

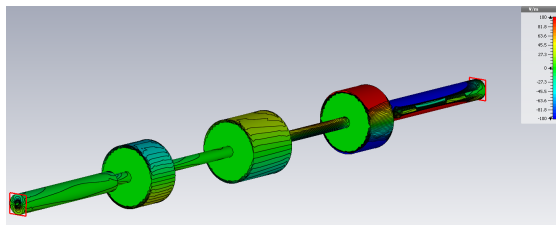

(c)

Field distribution (after CST) in coax-low-pass-filter at 0.5 GHz (a), 0.9 GHz (b), and in stop-band at 1.8 GHz (c).

Design of Distributed Band-Pass-Filter

- General approach is to transform prototype low-pass to band via a transformation function (for band-pass: $b(\omega) = \frac{\omega_0}{\Delta\omega} \left(\frac{\omega_0}{\omega} - \frac{\omega}{\omega_0} \right)$)
- Bandpass with coupled line section design equations:

$$\omega_0 = \sqrt{\omega_1 \omega_2}$$

$$\Theta_1 = \frac{\pi \omega_1}{2\omega_0} \quad ,$$

$$P \sin \Theta_1 = \frac{K'_{10}}{\sqrt{\frac{1}{2} \tan \Theta_1 + K'_{10}{}^2}} \quad ,$$

$$s = \frac{1}{\frac{1}{2} \tan \Theta_1 + K'_{10}{}^2} \quad .$$

Design of Distributed Band-Pass-Filter

- Values for impedance normalized (to Z_c) impedance inverters:

$$K'_{10} = K'_{n+1,n} = \frac{1}{\sqrt{\kappa_0 \kappa_1}} = \frac{1}{\sqrt{\kappa_n \kappa_{n+1}}} ,$$

$$K'_{k,k+1} = \frac{1}{\sqrt{\kappa_k \kappa_{k+1}}} .$$

- Some values come to aid:

$$\hat{N}_{k+1,k} = \sqrt{K'^2_{k+1,k} + \frac{1}{4} \tan^2 \Theta_1}$$

- And finally the even- and odd-mode impedances

$$Z_e^1 = Z_e^{n+1} = Z_c(1 + P \sin \Theta_1) ,$$

$$Z_o^1 = Z_o^{n+1} = Z_c(1 - P \sin \Theta_1) ,$$

$$Z_e^{k+1} = Z_e^{n-k+1} = Z_c s(\hat{N}_{k+1,k} + K'_{k+1,k}) ,$$

$$Z_o^{k+1} = Z_o^{n-k+1} = Z_c s(\hat{N}_{k+1,k} - K'_{k+1,k}) .$$

Design Results for Bandpass

Chebyshev, 1 dB equal-ripple filter, pass-band 11 ... 12 GHz, on $50\ \Omega$ -System,
Order $N = 7$ Impedances in Ω , Symmetry $Z_{N-k} = Z_k$

Z_{e1}	62.0	Z_{o1}	37.9
Z_{e2}	51.3	Z_{o2}	43.2
Z_{e3}	50.6	Z_{o3}	43.8
Z_{e4}	50.5	Z_{o4}	43.9

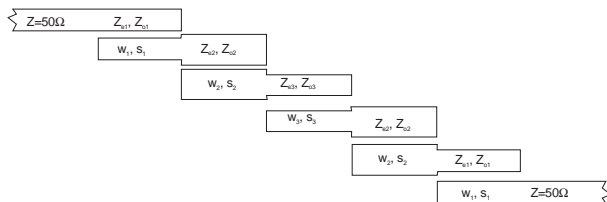

Layout (schematically) of a bandpass filter in microstrip technology



Bandpass Results I

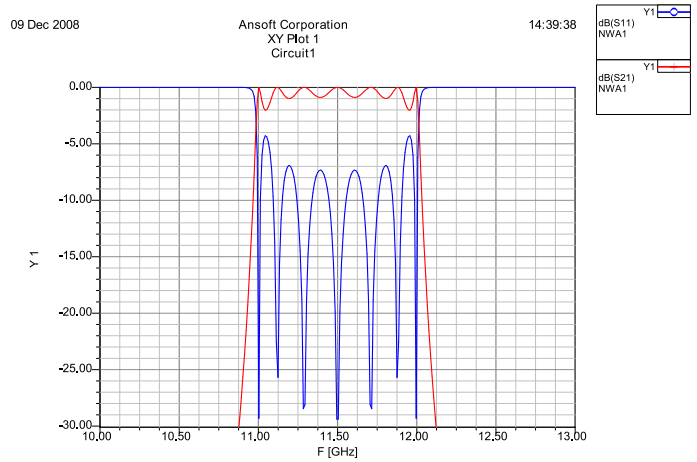

Simulation for bandpass filter ($N=7$) with ideal coupled transmission-lines (no end-effect, no real lines considered). Observe the number of ripples!

Bandpass Results II

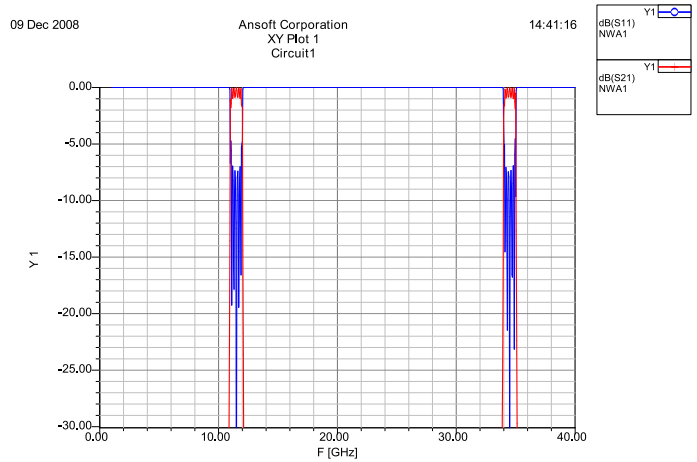

Simulation as above, observe the spurious pass-band at $3f_0$, where the lines have an electrical length of $3\lambda/2$. No passband at length λ !

Another Chebycheff-Bandpass

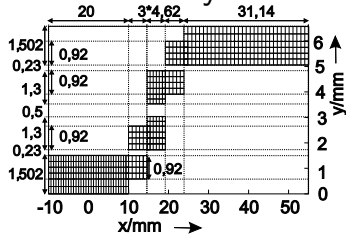
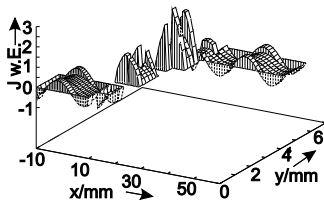

(a)

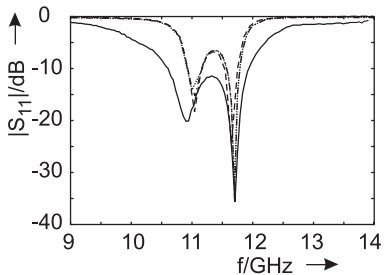

(b)

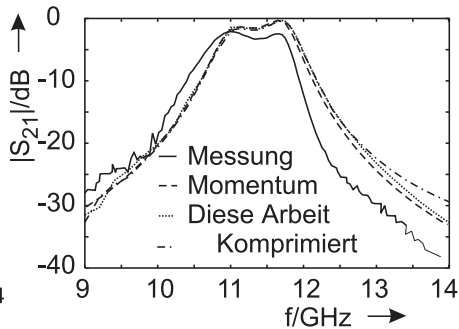

(c)

Rectangular Waveguide BPF

CST MICROWAVE STUDIO

07/30/2012 - 11:51

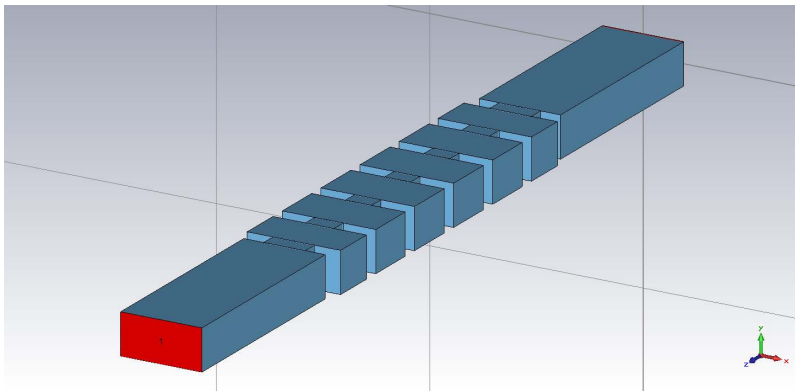

File: C:\Users\gerald\Documents\02_akademia\Simulationen\first_tries\hplane_filter.cst

Structure of H-Plane steps as bandpass filter in rectangular waveguide technology after [2]

H-Plane-Filter-Results

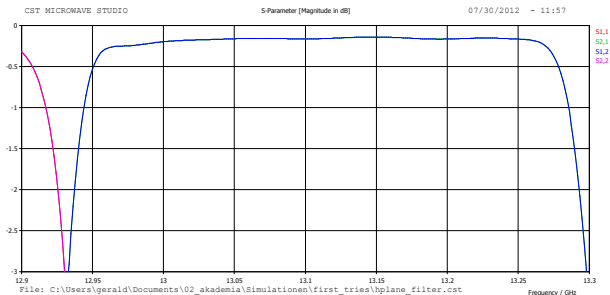
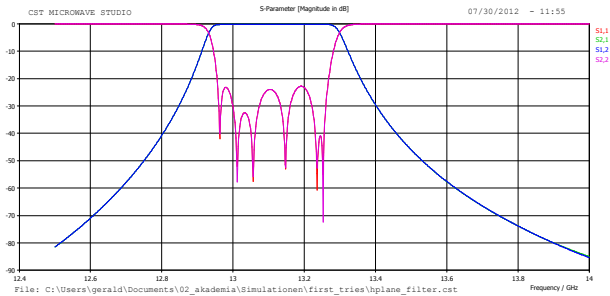

Field-Distribution in H-Plane-Filter

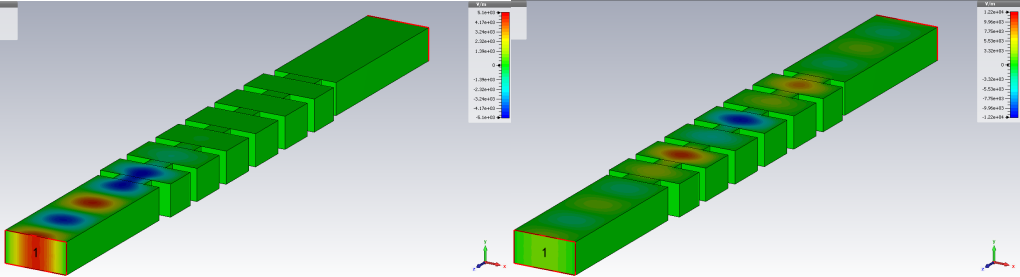

(a)

(b)

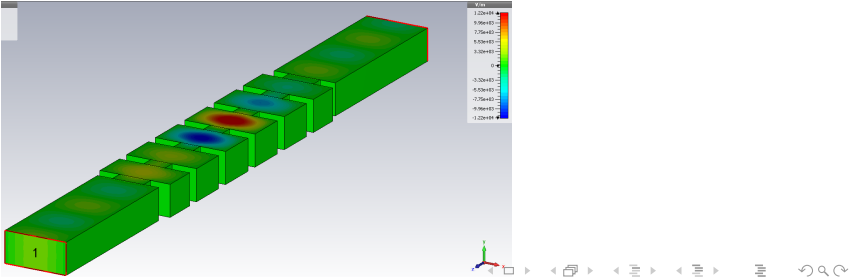

What We Did And What We Did Not

You just experienced

- A brief walk through passive components, and how they are being used and treated in RF-engineering
- An introduction to components somewhat special to RF, such as couplers and dividers, SAW-components
- A primer on (analogue) filter design

We left out

- All ferri-magnetic components
 - Circulator
 - Director
- Anisotropies, also in magnetics and in dielectrics.

References



G. Oberschmidt. *Waveletbasierte Simulationswerkzeuge für planare Mikrowellenschaltungen*. Bd. 293. 9. Düsseldorf: VDI Fortschritt-Berichte, 1998.



Jorge A. Ruiz-Cruz, Jose R. Montejo-Garai und Jesus M. Rebollar. *Computer Aided Design of Waveguide Devices by Mode-Matching Methods*. 10. Sep. 2012. URL: <http://www.intechopen.com/books/passive-microwave-components-and-antennas/computer-aided-design-of-waveguide-devices-by-mode-matching-methods>.

Transistors: Technology, Performance

- RF Basics
- System Overview
- Fields & Waves
- Transmission Lines
- Practical TL
- 2-Port and S-Parameters
- Matching
- Antennas
- Passives
- Transistors**
- FET
- HEMT
- Linear

- 8 Antennas
- 9 Passive Components and Filters
- 10 Transistors: Technology, Performance**
- 11 Amplifier: Linear and Design with S-Parameters
- 12 Noise and Stochastic Processes
- 13 Non-Linearities and Power Amplifiers

- Learn about different types of RF transistors
- Know, when to use which types
- know state of the art performance parameters
- Worry about non-idealism: Noise and compression (harmonics) and deal with it

- Used (Semiconductor) material
 - Silicon (Si) in Bipolar junction transistors, as far up (in frequency) as one can push it.
 - III-V-Semiconductors ([Aluminum] Gallium Arsenide [Al]GaAs, Indium Phosphide InP) for high frequencies (because of high electron mobility in material) and more freedom in designing the junction (Hetero Bipolar Transistor)
 - Silicon Germanium (SiGe) for higher frequencies (than Si) because of higher electron mobility and as well good integrability with common Si-chips (digital)
- Bipolar Junction Transistor (NPN, PNP), Hetro Bipolar Junction Transistor (HBT)
- Field Effect Transistor (FET): Metal Semiconductor (Junction) FET (MESFET), Metal Oxide Semiconductor FET (MOSFET) well known from usual digital electronics, High Electron Mobility Transistor (HEMT) especially designed MESFET

BJT Geometry

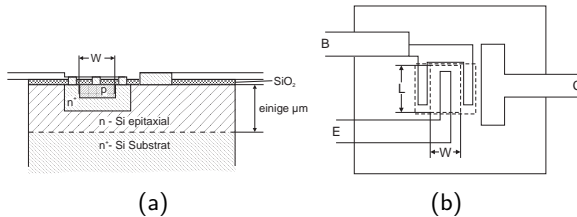

Geometry of a bipolar junction transistor

- Maximize highest possible frequency of oscillation (point where power gain is still one:
$$\omega_{max} = \frac{1}{2} \sqrt{\frac{\omega_{\alpha}}{r_b c_c}}$$
 (for explanation of factors see next slides.)
- Mobility of electrons/ diffusion through base is given by material (more or less, see later HEMT)
- Make sure base zone is narrow
- Minimize r_b through wide base-cross-section and small base-width
- Wide collector-junction for small capacitance c_c

BJT: Field, Current and Structures

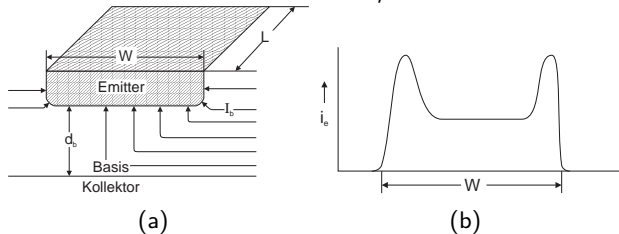

Field and current distribution for striped geometry

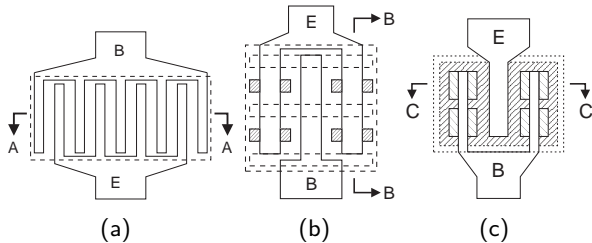

Bipolar Junction transistor (BJT)

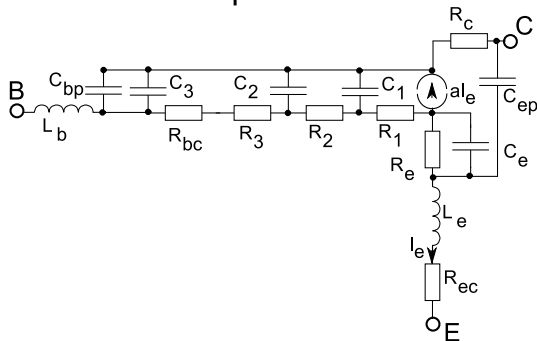

Equivalent circuit of a bipolar junction transistor

C_{bp}	base bond pad cap.	C_{ep}	emitter bond pad cap.
R_{bc}	base contact res.	R_{ec}	emitter contact res.
R_1, R_2, R_3	base distributed res.	C_1, C_2, C_3	collector-base distr. cap.
R_e	dynamic e-b diode res.	C_e	e-b diode junction cap.
R_c	collector res.	L_b, L_e	base & emitter bond wire ind.

Example values for a BJT Avantek AT60500 silicon bipolar transistor with
 $I_c = 2 \text{ mA}$, $U_{ec} = 8 \text{ V}$

$C_{bp} + C_3 = 0.055 \text{ pF}$	$C_1 = 0.01 \text{ pF}$
$C_2 = 0.039 \text{ pF}$	$C_{ep} = 0.26 \text{ pF}$
$C_e = 0.75 \text{ pF}$	$R_{bc} + R_3 = 4.2 \Omega$
$R_{ec} = 0.66 \Omega$	$R_1 = 7.5 \Omega$
$R_2 = 10.3 \Omega$	$R_e = 12.9 \Omega$
$R_c = 5 \Omega$	$L_b = 0.5 \text{ nH}$
$L_e = 0.2 \text{ nH}$	$\tau_d = 6.9 \text{ ps}$

So we have a base cut-off frequency of $f_b = \frac{D_{nb}}{\pi d_b^2} = 22.7 \text{ GHz}$. D_{nb} Diffusion constant in the base, d_b width of base.

Common base current gain $\alpha = \frac{\alpha_0 e^{-j\omega\tau_d}}{1 + jf/f_b}$

τ_d collector depletion region delay time.

BJT: Usage in Common-Emitter Circuit

- Advantageous input and output impedance

- higher current-gain than in common-base

- short circuit gain $\alpha_e^* = \frac{\alpha^*}{1-\alpha^*}$ with effective $\alpha_{eff}^* \Rightarrow \alpha_e^* \approx \frac{\alpha \cdot e^{-jm\omega\tau_b}}{1-\alpha \cdot e^{-jm\omega\tau_b} + j\frac{\omega}{\omega_{ec}}}$

- Transit-frequency: $|\alpha_e^*(\omega_T)| = 1$

- for LF-Transistor: $\omega_T = \omega_\alpha$

- for LF-Transistor: $\omega_T = \frac{\omega_{ec}}{1+m\omega_{ec}\tau_b}$ ($\alpha \approx 1$)

HBT: Structure

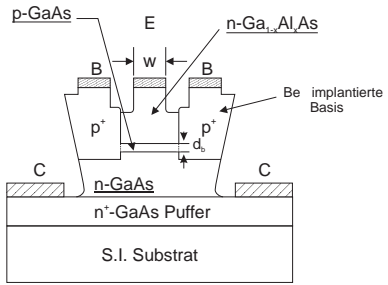

Structure of a Hetero junction bipolar transistor

- vertical structure → less surface states as in planar structures (FET) → less 1/f - noise (important for non-linear applications as in oscillators. HBT comparable with Bipolar-Transistor, ca. 10 dB better than FET)
- high power, because entire Emitter-cross-section is available.

Hetero Bipolar Transistor (HBT)

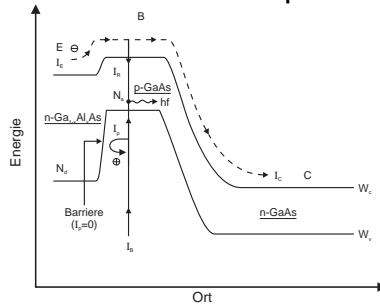

- RF limit because of r_b and d_b
- Contradiction: d_b small for ω_α large, d_b large for r_b small
- Solution: Bipolar-Transistor with Emitter-Basis-Hetero-Junction: E: n-AlGaAs, B: p-GaAs, C: n-GaAs
- large barrier E-B \rightarrow holes of B cannot go to E $\hookrightarrow \gamma \approx 1$
- Base-width d_b very small ($< 0,1\mu\text{m}$) $\hookrightarrow \tau_{ec} \searrow, f_T \nearrow \rightarrow$ solve problem with r_b large

HBT: Results

- f_{max} = 604 GHz (2005, University of Illinois at Urbana-Champaign)
- Material (for record: InP - InGaAs)
- for mobile application material SiGe

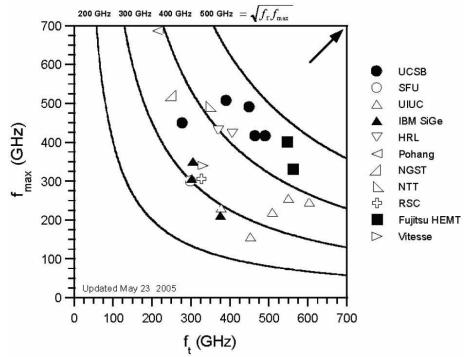

Recent (2005/6) results for InP DHBT, after Rodwell e.a. "Frequency Limits of Bipolar Integrated Circuits", IEEE-MTT Symp.

2006, pp.329

Field Effect Transistor

10 Transistors: Technology, Performance

- Field Effect Transistor
- High Electron Mobility Transistor

11 Amplifier: Linear and Design with S-Parameters

Field Effect Transistor (FET)

- RF Basics
- System Overview
- Fields & Waves
- Transmission Lines
- Practical TL
- 2-Port and S-Parameters
- Matching
- Antennas
- Passives
- Transistors
 - FET
 - HEMT
- Linear

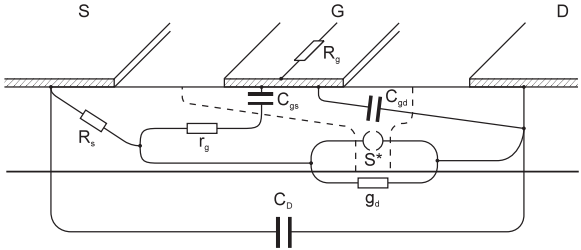

Pictorial derivation of equivalent circuit for a MESFET

FET: Equivalent Circuit

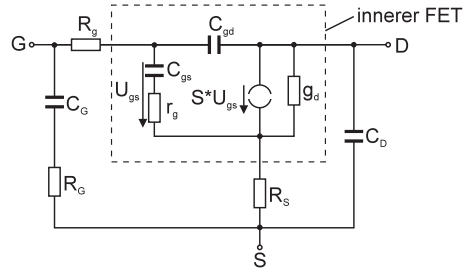

High frequency equivalent circuit of a FET Change compared to the static case:

- Channel conductance g_d unchanged
- Voltage controlled current source: $S \rightarrow S^* \approx \frac{S}{1+j\omega\tau_s}$
for $\omega\tau_s \ll 1$ τ_s : Channel drift or transit time
- Order of magnitude $\tau_s \approx \frac{l}{\bar{v}_D}, \bar{v}_D = \mu_n \frac{U_{DS}}{l}$
 $\tau_s \approx \frac{l}{v_s}$, if E_s (Saturation in entire channel)

The Additional RF-Elements I

- Gate-Source-Capacitance:

$$C_{gs} = \varepsilon \cdot a \cdot \int_0^l \frac{dx}{w}$$

a - Gatewidth, w - Junction thickness, l - Gatelength

$$C_{gs} \approx (2 \dots 3) \cdot C_0, C_0 = \frac{\varepsilon \cdot a \cdot l}{d} \text{ Junctioncap for } w = d = \text{const}$$

- r_g : Resistance of the Channel R-C-transmission-line \rightarrow with r_g, C_{gs} :
time-delay (order of magnitude) $\tau_g = \frac{\varepsilon}{\sigma} \cdot \left(\frac{l}{d}\right)^2$
- Gate-Drain:

C_{gd} : parasitic cap at edge of Gate

$$C_{gd} \approx \varepsilon \cdot a \text{ for } \varepsilon_r = 12 : \frac{C_{gd}}{a} = \frac{1pF}{cm}$$

Outer elements: Line- and Connector-resistances, caps.

The Additional RF-Elements II

- Source-Resistor: R_s conductor resistor between Source and Channel
 R_s Voltage divider for input voltage \rightarrow limits voltage control and generated feedback

R_s small \rightarrow S - contact close to channel.

- Gate - Resistance

R_g : Specific resistance of Gate-contact is high

E.g.: $R'_g = 10k\Omega/cm$

Gate-contact narrow: limits electrolytic gain.

Gate-contact acts like transmission line with R'_g, C'_g and length a ($G', L' \approx 0$).

\rightarrow characteristic impedance: $Z_g = \sqrt{\frac{R'_g}{j\omega C'_g}}$

\rightarrow propagation coefficient: $\gamma = \sqrt{j\omega C'_g \cdot R'_g}$

The Additional RF-Elements III

● Gate - Resistance (continued)

Input resistance for open (no current in Gate): $Z_E = Z_g \cdot \coth(\gamma \cdot a)$

$$\text{for } |\gamma \cdot a| \ll 1 \rightarrow \coth x \approx 1/x + x/3 \rightarrow Z_E \approx \frac{1}{j\omega C'_g \cdot a} + \frac{R'_g \cdot a}{3}$$

$$R_g = \text{Re}\{Z_E\} = \frac{R'_g \cdot a}{3}$$

Input voltage is divided like $\text{Re}\{Z_E\} / \text{Im}\{Z_E\}$ between R_g and inner FET
 \hookrightarrow division like $\sim a^2 \Rightarrow$ Gate-length short \rightarrow more Gate-contacts in parallel.

E.g.: Two Gate-contacts in parallel

$$\hookrightarrow R_g = \frac{R'_g \cdot a}{12} \approx 30\Omega \quad a: \text{total Gate-length}$$

with $a/2 = 200 \mu\text{m}$

The Additional RF-Elements IV

- Parasitic caps of Gate and Drain, of lines and contacts: C_G, C_D

E.g.: GaAs-FET, $l = 1 \mu\text{m}$, $a = 300 \mu\text{m}$

$$S = 30 \text{ mS} \quad C_{gs} = 0,4 \text{ pF} \quad r_g = 3 \Omega \quad R_g = 2 \Omega$$

$$g_d = 2 \text{ mS} \quad C_{gd} = 0,01 \text{ pF} \quad \tau_s = 3 \text{ ps} \quad R_s = 5 \Omega$$

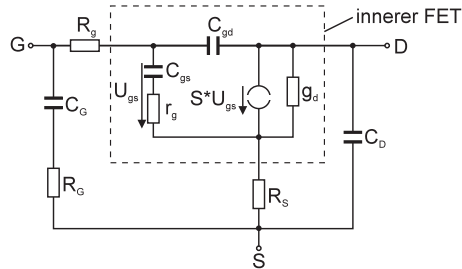

High frequency equivalent circuit of a FET (repeated)

FET: Frequency Limits

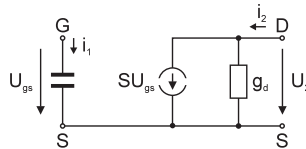

(Much) simplified equivalent circuit for FET

- Drift-delay and -loss:

$$|S^*| = \frac{S}{\sqrt{2}} \quad \text{with } \omega_s = \frac{1}{\tau_s}$$

- Transit-frequency and short-circuit current gain α_{SC} :

$$\alpha_{SC} = \frac{i_2}{i_1} \Big|_{U_2=0} = \frac{S}{j\omega C_{gs}}$$

FET: Frequency Limits II

- Transit-frequency (continued)

$$|\alpha_{SC}| = 1 \text{ at } f = f_T = \frac{1}{2\pi} \cdot \frac{S}{C_{gs}}$$

$$\omega_T = 2\pi f_T = \frac{S}{C_{gs}} = \frac{S}{g_d} \cdot \frac{g_d}{C_{gs}} = \mu \cdot B$$

- μ : Open-circuit voltage gain, B : Bandwidth.

With $\omega_{T0} = 2\pi f_{T0} = 2 \cdot U_p \cdot \frac{\mu_n}{l^2}$ with U_p : Pinchoff-Voltage, μ_n : mobility

FET: Frequency Limits III

- and S, C_{gs} from more accurate physical model

| bzw. U_s large: $\hookrightarrow f_T \sim l^{-2}$

| bzw. U_s small: $\hookrightarrow f_T \sim l^{-1}$

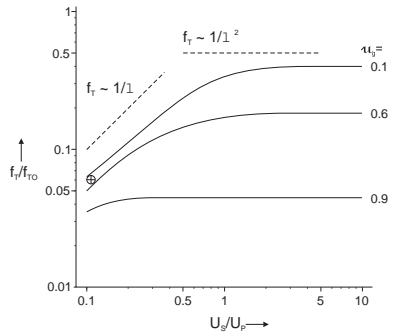

High Electron Mobility Transistor

10 Transistors: Technology, Performance

- Field Effect Transistor
- High Electron Mobility Transistor

11 Amplifier: Linear and Design with S-Parameters

High Electron Mobility Transistor (HEMT)

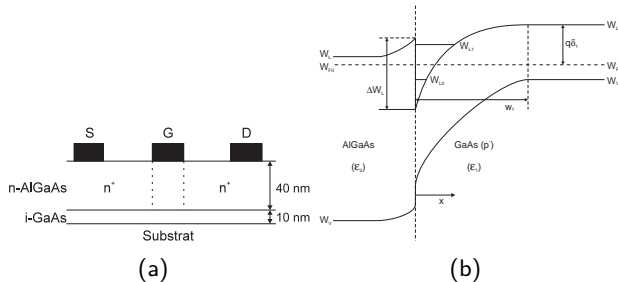

Heterostructure and energy levels (bands) in a HEMT

- At hetero-junction electrons diffuse from n-doped AlGaAs-layer to un-doped GaAs-layer.
→ very good RF-properties because of much decreased scattering (less donators)
($\mu \uparrow, v_s \uparrow$)
- Application:
 - Amplifiers for μ /mm Waves (low-noise, power)
 - fast logic circuits

HEMT: Technology I

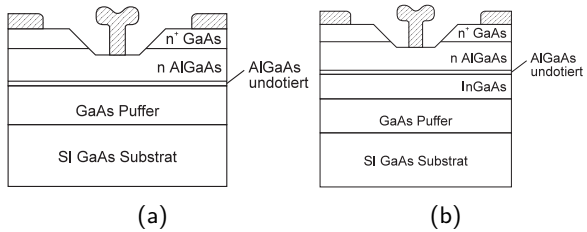

Usual HEMT, and Pseudomorphic HEMT (P-HEMT)

- "Mushroom"-Gate for $R_g \downarrow$
- P-HEMT
 - AlGaAs/InGaAs-Hetero-junction
 - \Rightarrow - better e-transport properties
 - Energy-gap ΔW_L larger (more electrons)
 - Lattice-constant of InGaAs \neq AlGaAs, GaAs, its mismatch growth with In-ratio (1,5% for 22% In-portion)
 - \Rightarrow InGaAs-layer so thin, that voltages from neighboring layers can be taken

HEMT: Technology II

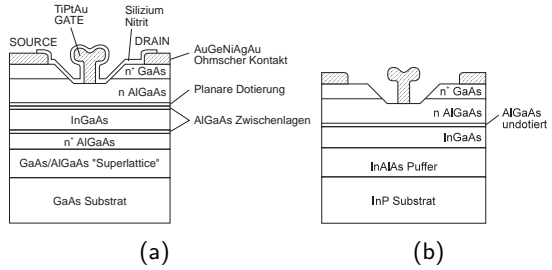

P-HEMT with double-hetero-junction and HEMT on InP Some Performance figures (independent of technology)

- GaAs-FET:
 - $F_{min} \approx 1\text{dB}$ at 10 GHz; $\leq 2\text{dB}$ at 20 GHz; $\leq 4\text{dB}$ at 60 GHz
- GaAs-HEMT: (Gatelength $l = 0,25\mu\text{m}$) $F_{min} \leq 2\text{dB}$ bei 60 GHz as
 - P-HEMT: $f_T \approx 170\text{GHz}$ $f_{u,max} \approx 350\text{GHz}$
- InP-HEMT: ($l = 0,2\mu\text{m}$) $F_{min} \approx 0.8\text{dB}$ at 64 GHz at $G = 8.7\text{dB}$

References

RF Basics

System
Overview

Fields &
Waves

Transmission
Lines

Practical TL

2-Port and
S-Parameters

Matching

Antennas

Passives

Transistors

FET

HEMT

Linear

Amplifier

Amplifier: Linear and Design with S-Parameters

- 9 Passive Components and Filters
- 10 Transistors: Technology, Performance
- 11 Amplifier: Linear and Design with S-Parameters**
- 12 Noise and Stochastic Processes
- 13 Non-Linearities and Power Amplifiers
- 14 Power Amplifiers

What you Should Know after this Session

- Know what people can mean, when they talk about gain
- Know the basic design fundamentals
- Know that there are trade-offs between stability, gain, noise, efficiency, linearity and maybe more
- Use S-Parameter data file of a transistor
- Do the matching (Again: That's what it's all about...)

Amplifier Design: Some Goals

Some CONCURRENT design goals for amplifiers

- ① High (maximum) power gain with fair (low) DC power-consumption and with fair linearity
- ② Low (minimum) noise in the first stage of a pre-amplifier
- ③ Stability (an absolute must, otherwise amplifier is unusable)
- ④ Low (minimum) input- and output-reflection
- ⑤ Adequate and uniform gain in desired band
- ⑥ Linear phase throughout the band (only group delay)
- ⑦ In-sensitive to drift in S-parameters (e.g. temperature)

and many more

Structure of an Amplifier

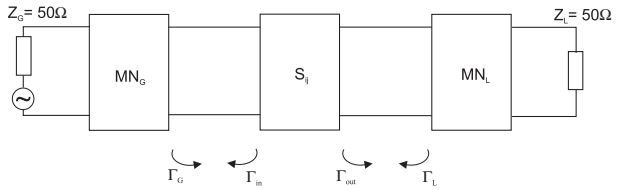

The amplifier in three parts: Input matching, amp, output matching Amplifier design is

- Determine transistor and bias-point to be used (S-Parameters)
- Develop the needed matching networks to it

S-Parameters: A Practical Convention

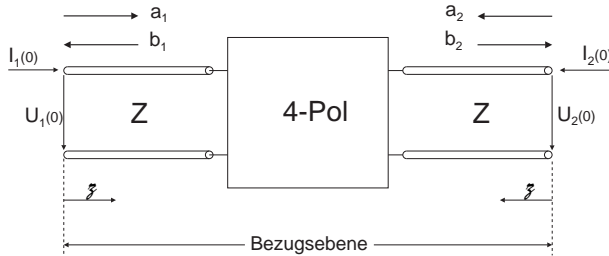

Defining waves at two-port

Measurement of the waves a_i, b_i instead of U_i, I_i

$$\begin{pmatrix} b_1 \\ b_2 \end{pmatrix} = \underbrace{\begin{pmatrix} S_{11} & S_{12} \\ S_{21} & S_{22} \end{pmatrix}}_{\text{scattering matrix}} \cdot \begin{pmatrix} a_1 \\ a_2 \end{pmatrix}, \text{ short } [b] = [S] \cdot [a]$$

Scattering Matrix and Scattering Parameter $S_{i,j}$

Physical Meaning

The physical meaning and a hint form measuring the S-Parameters

$$S_{11} = \left. \frac{b_1}{a_1} \right|_{a_2=0} \quad : \quad \text{Input-reflection for matched output}$$

$$S_{22} = \left. \frac{b_2}{a_2} \right|_{a_1=0} \quad : \quad \text{Output-reflection for matched input}$$

$$S_{21} = \left. \frac{b_2}{a_1} \right|_{a_2=0} \quad : \quad \text{Transmission factor from input to output}$$

with matched output

$$S_{12} = \left. \frac{b_1}{a_2} \right|_{a_1=0} \quad : \quad \text{Transmission factor from output to input}$$

for matched input

- RF Basics
- System Overview
- Fields & Waves
- Transmission Lines
- Practical TL
- 2-Port and S-Parameters
- Matching
- Antennas
- Passives
- Transistors
- Linear Amplifier
- Stability**

- 11 Amplifier: Linear and Design with S-Parameters
 - **Stability**
 - Power Gain
 - Low Noise Amplifier

- 12 Noise and Stochastic Processes

First of All: Stability

Very simple: An amplifier must be stable at all frequencies (not only in desired band!) otherwise it is no amplifier.

- Active elements (i.e. transistors) can feed back, at least internally there is feedback, almost always
- With the internal amplification this feedback can lead to oscillation

Stability criteria, stability can be assessed by S-Parameters of the active device (transistor)

- ① Absolute stability: stable for all (passive) generators Z_G and loads Z_L
- ② Conditionally stable: only stable for some Z_G and Z_L and combinations thereof. Make sure your device operates only (and at all frequencies) only in the stable area.

Stability in Pictures

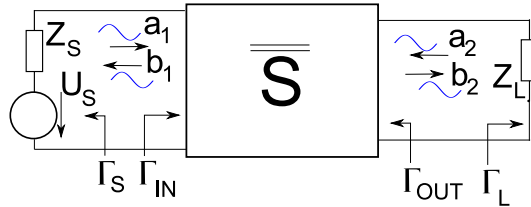

Definition of variables (in-output-reflection)

- Input reflection $\Gamma_{in} = \frac{b_1}{a_1} = S_{11} + \frac{S_{21}S_{12}\Gamma_L}{1-S_{22}\Gamma_L}$
- Output reflection $\Gamma_{out} = \frac{b_2}{a_2} = S_{22} + \frac{S_{21}S_{12}\Gamma_G}{1-S_{11}\Gamma_G}$
- **Stability** is given if $|\Gamma_{in}| < 1$, $|\Gamma_{out}| < 1$
- Thus for Γ_L this means $\left| S_{11} + \frac{S_{21}S_{12}\Gamma_L}{1-S_{22}\Gamma_L} \right| < 1$

- Afore mentioned condition means that all Γ_L that just barely fulfill the condition of stability lie on a circle in the reflection plane (Smith-diagram)
- Center is $M_L = \frac{(S_{22} - S_{11}^* \Delta)^*}{|S_{22}|^2 - |\Delta|^2}$, $\Delta = S_{11} S_{22} - S_{12} S_{21}$
- Radius is $\rho_L = \left| \frac{S_{21} S_{12}}{|S_{22}|^2 - |\Delta|^2} \right|$

Stability Circle: Graphically

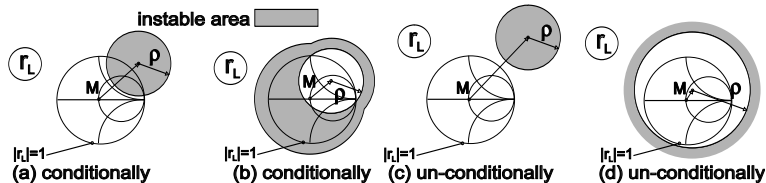

Different cases of stability circles. (Region designation valid for $|S_{11}| < 1$). $|r_L| = 1$ denotes all possible passive loads.

- ① Stable outside circle, and circle intersects Smith diagram for Γ_L : Conditionally stable
- ② Stable inside circle, and circle intersects Smith diagram for Γ_L : Conditionally stable
- ③ Stable outside circle, and circle does not intersect Smith diagram for Γ_L :
Unconditionally stable
- ④ Stable inside circle, and circle surrounds Smith diagram for Γ_L : Unconditionally stable

Stability can be put together in only one factor:

The stability criterion

$$K = \frac{1 - |S_{11}|^2 - |S_{22}|^2 + |\Delta|^2}{2 |S_{12} S_{21}|} > 1$$

- If $K > 1$ the device is unconditionally stable (for the S-Parameters i.e. frequency and biasing given)
- If not, the device is conditionally stable, this means you need to find the load and generator impedance that leads to a stable operation
- The closer to zero, the more difficult it is to get a device stable.

- RF Basics
- System Overview
- Fields & Waves
- Transmission Lines
- Practical TL
- 2-Port and S-Parameters
- Matching
- Antennas
- Passives
- Transistors
- Linear Amplifier
- Stability

- 11 Amplifier: Linear and Design with S-Parameters
 - Stability
 - Power Gain**
 - Low Noise Amplifier

- 12 Noise and Stochastic Processes

The Definition of Power-Gain

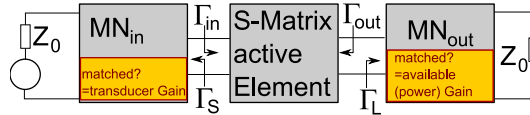

Power is easy to measure, but there are several definitions for gain, most of that originate from that fact that people not only ask: What is it you have?, but also ask,: What would be if we had only...?

Power-Gain

$$G_P = \frac{\text{Power at Load}}{\text{Input Power to Amp.}}$$

Transducer Gain

$$G = \frac{\text{Power at Load}}{\text{Available Power of Source}}$$

Available (Power) Gain

$$G_v = \frac{\text{Available Power at Load}}{\text{Available Power of Source}}$$

Derivation of Power-Gains

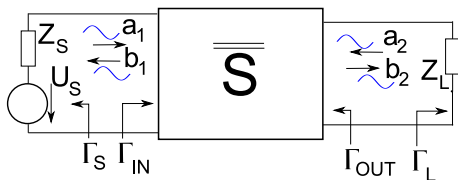

Just to keep in mind the definitions.

Normalized load-/generator impedances/ reflections $\Gamma_L = \frac{Z_L - Z_0}{Z_L + Z_0}$; $\Gamma_s = \frac{Z_s - Z_0}{Z_s + Z_0}$

And now
$$\begin{pmatrix} b_1 \\ b_2 \end{pmatrix} = \begin{pmatrix} S_{11} & S_{12} \\ S_{21} & S_{22} \end{pmatrix} \begin{pmatrix} a_1 \\ a_2 \end{pmatrix} \quad \text{and} \quad \begin{aligned} a_1 &= \Gamma_s b_1 + a_s \\ a_2 &= \Gamma_L b_2 \end{aligned}$$

And so we have

$$b_2 = S_{21} a_1 + S_{22} \Gamma_L b_2 \Leftrightarrow b_2 = \frac{S_{21} a_1}{1 - S_{22} \Gamma_L}$$

and finally
$$\frac{b_1}{a_1} = \Gamma_{in} = \frac{S_{11} - \Delta \Gamma_L}{1 - S_{22} \Gamma_L} \quad \Delta = \det \bar{S}, \quad \frac{b_2}{a_2} = \Gamma_{out} = \frac{S_{22} - \Delta \Gamma_s}{1 - S_{11} \Gamma_s}$$

Input Conditions

It all depends on how much power we get into this thing

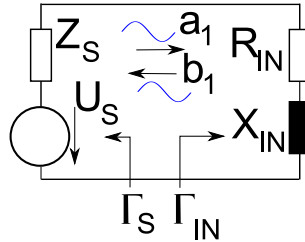

- Power at input is difference between forward and backward travelling wave:

$$P_{in} = |a_1|^2 - |b_1|^2 = |a_1|^2(1 - |\Gamma_{in}|^2)$$

- Power at output is similar (but other way around)

$$P_L = |b_2|^2 - |a_2|^2 = |b_2|^2(1 - |\Gamma_L|^2)$$

Power at the Output Port

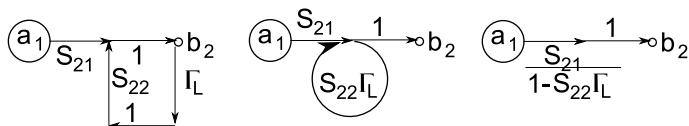

Signal-flow-graph to depict conditions at the output port

- Outward travelling wave is $b_2 = a_1 \frac{S_{21}}{1 - S_{22}\Gamma_L}$

And so the power is

$$P_L = |a_1|^2 \frac{(1 - |\Gamma_L|^2) |S_{21}|^2}{|1 - \Gamma_L S_{22}|^2}$$

And consequently the **Power Gain**, which is, what the amplifier really does, it does not show how much the situation actually is improved by the amp

$$G_p = \frac{P_L}{P_{in}} = \frac{(1 - |\Gamma_L|^2) |S_{21}|^2}{|1 - \Gamma_L S_{22}|^2 (1 - |\Gamma_{in}|^2)}$$

How Much Better is it with Amp?

If you do bad at the input of the amp, what happens? The amp has to gain much, but compared to no-amp, the situation is not improved much. Thus, compare to best possible solution without amp, i.e. **Transducer Gain**

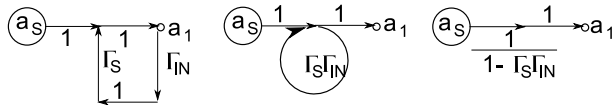

- Power at input of amp is $a_1 = \frac{a_S}{1 - \Gamma_S \Gamma_{in}}$
- Available power is for $\Gamma_{in} = \Gamma_S^*$ and is $P_{ava} = |a_1|^2 - |b_1|^2 = |a_S|^2 \frac{1}{1 - |\Gamma_S|^2}$
- And so the input power (in terms of available power) is

$$P_{in} = P_{ava} \frac{(1 - |\Gamma_{in}|^2)(1 - |\Gamma_S|^2)}{|1 - \Gamma_S \Gamma_{in}|^2}$$

Gain – Almost Done

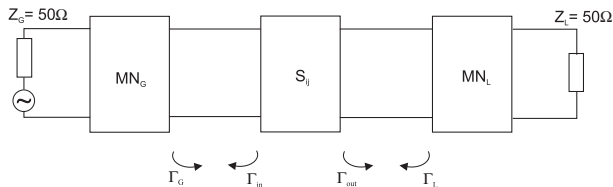

The amplifier in three parts: Input matching, amp, output matching

$$G = \frac{P_L}{P_{ava}} = \frac{(1 - |\Gamma_L|^2)(1 - |\Gamma_S|^2)|S_{21}|^2}{|1 - \Gamma_L S_{22}|^2 |1 - \Gamma_{in} \Gamma_S|^2}.$$

That is difficult, because there is a Γ_{in} in there. So we just set $S_{12} \approx 0$, which is mostly almost true and then $\Gamma_{in} \approx S_{11}$ and so **Transducer Gain**

$$G' = \frac{(1 - |\Gamma_S|^2)}{|1 - S_{11} \Gamma_S|^2} |S_{21}|^2 \frac{(1 - |\Gamma_L|^2)}{|1 - \Gamma_L S_{22}|^2}.$$

Gain – Final Slide (really)

And here is, what we get at most for an unconditionally stable out of the (poor) transistor

$$G_{max} = \left| \frac{S_{21}}{S_{12}} \right| (K \pm \sqrt{K^2 - 1}) .$$

- The —-sign is the one valid for passive loading.
- Ratio $\left| \frac{S_{21}}{S_{12}} \right|$ is also called the “figure of merit” and gives the maximum stable gain (i.e. $K = 1$)

Low Noise Amplifier

- RF Basics
- System Overview
- Fields & Waves
- Transmission Lines
- Practical TL
- 2-Port and S-Parameters
- Matching
- Antennas
- Passives
- Transistors
- Linear Amplifier
- Stability

- 11 Amplifier: Linear and Design with S-Parameters
 - Stability
 - Power Gain
 - Low Noise Amplifier

- 12 Noise and Stochastic Processes

Design of a Low Noise Amplifier

Tools and Goal

- Smith-Diagram (SD) and Constant Gain and Noise Circles
- Low noise with fair matching at input and output
- Stability

How to

- ① Select transistor (use knowledge from earlier chapters)
- ② Draw instable sections in SD, so that you know what to avoid
- ③ Construct input matching circuit, to match Γ_{opt} as point for optimum noise figure
- ④ Construct output matching to match to Γ_L^*
- ⑤ If required find compromises by using circles in SD

Matching in Circles (Teaser)

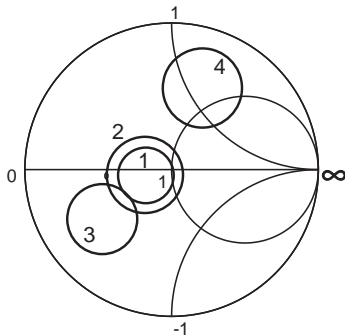

Legende:

(1) $\Gamma_{in}^*(F_m+0.5\text{dB})$

(2) $\Gamma_{in}^*(F_m+1\text{dB})$

(3) $\Gamma_{in}^*(G_p=10\text{dB})$

(4) $\Gamma_L(G_p=10\text{dB})$

Impedances that lead to the same noise-figure or gain can be drawn as circles in the Smith-Diagram

- Advanced technique to find compromises between gain, match and noise
- Support by design Software, as e.g. by Ansoft
- Caveat: For power amps these circles degenerate to ovals (no analytical description available)

The Matching Network

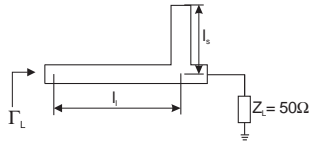

Example for a matching network... and its representation in the Smith-chart:

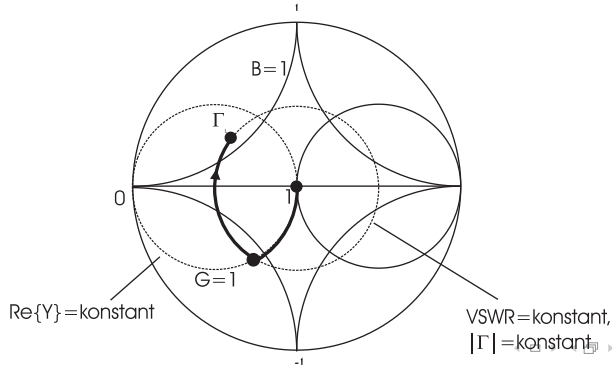

- RF Basics
- System Overview
- Fields & Waves
- Transmission Lines
- Practical TL
- 2-Port and S-Parameters
- Matching
- Antennas
- Passives
- Transistors
- Linear Amplifier
- Stability

Bias Network

What for?

- The S-Parameters from data-sheet describe the linear performance of a transistor at clearly specified biasing conditions (working point)
- DC power must be applied to bring the transistor to its desired (linear) performance condition

How?

- Biasing networks shall present no loss to the DC power and
- shall be invisible to the RF (i.e. Matching at load and generator side must not be disturbed)
- RF-chokes possible (beware of resonance frequency of those things at few 100 MHz)
- Use (narrow-band) band-stop filter, (i.e. $\frac{\lambda}{4}$ -transmission lines, that transform shorts (DC-connection with capacitive RF-grounding) to open at “hot-wire”)

Two Practical Biasing-Networks

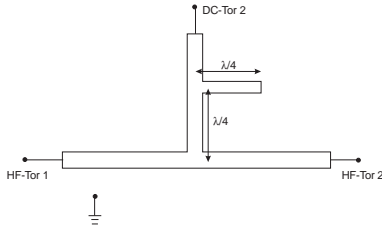

Simple Biasing-nw with $\lambda/4$ -Stubs

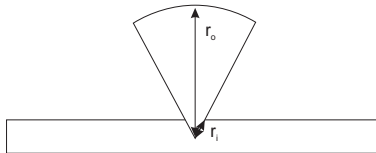

Radial stub used to RF-shorten a line

Complete Layout of the RF-LNA

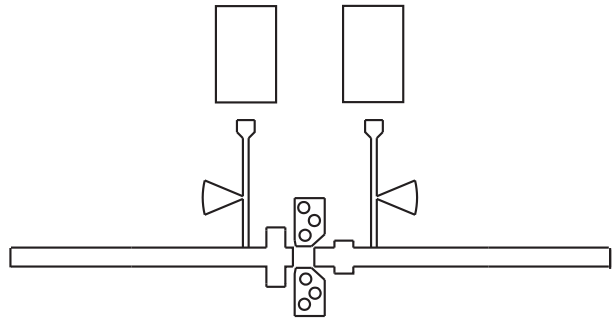

Note:

- Double stubs and lines for matching
- $\lambda/4$ -transformation and radial RF-shorts for biasing
- Multiple vias for proper grounding of FET-sources

References

RF Basics

System
Overview

Fields &
Waves

Transmission
Lines

Practical TL

2-Port and
S-Parameters

Matching

Antennas

Passives

Transistors

Linear
Amplifier

Stability

Noise and Stochastic Processes

- RF Basics
- System Overview
- Fields & Waves
- Transmission Lines
- Practical TL
- 2-Port and S-Parameters
- Matching
- Antennas
- Passives
- Transistors
- Linear Amplifier

- 10 Transistors: Technology, Performance
- 11 Amplifier: Linear and Design with S-Parameters
- 12 Noise and Stochastic Processes**
- 13 Non-Linearities and Power Amplifiers
- 14 Power Amplifiers
- 15 Mixers for Frequency Translation

- RF Basics
- System Overview
- Fields & Waves
- Transmission Lines
- Practical TL
- 2-Port and S-Parameters
- Matching
- Antennas
- Passives
- Transistors
- Linear Amplifier
- Noise

- 12 Noise and Stochastic Processes
 - Noise Basics
 - Thermal Noise
 - 2-Port-Noise-Figure
 - Noise Temperature and Measurement
 - Chain Formula
- 13 Non-Linearities and Power Amplifiers

At First: The Result

Thermal noise

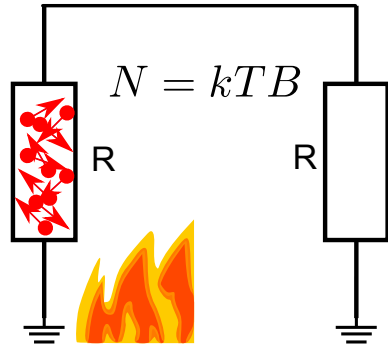

(Available) Noise-power of a (matched) resistor pair

- $N = k \cdot T \cdot B$
- $k = 1.38 \cdot 10^{-23} \text{ Ws/K}$, $T = 290$, $B = \text{Bandwidth}$
- Or $N = -174 \text{ dBm} + 10 \log B/\text{Hz}$
- Available voltage $\sqrt{u^2} = \sqrt{4kTB R}$

Noise and Stochastic Processes

Noise is a stochastic process, the time dependence is arbitrary. No meaningful description in time-domain is available or of interest.

Thus noise is described with statistical methods:

- Time dependent (voltage) function $u(t)$
- Probability density function (short: pdf), its integral must equal 100% (that's a definition)

$$\int_{-\infty}^{\infty} \rho(y) dy = 1.$$

- $\rho(y) dy$ is the probability that the amplitude is in the range of y to $y + dy$.

Random Data (Pictorial)

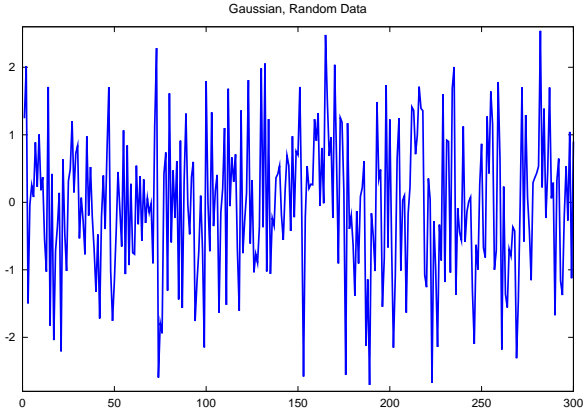

Random amplitude distribution for normal distribution with mean 0 and standard deviation 1. Note that values above 2 or below -2 are not uncommon!

Normal (Gaussian) Distribution

- For distribution of electrical noise a description with normal- or gaussian distribution is close to reality and mathematically convenient.

- Gaussian density function is

$$\rho(y) = \frac{1}{\sqrt{2\pi}\sigma} e^{-\frac{(y-\mu)^2}{2\sigma^2}}$$

μ Average or mean(value), σ^2 : Variance, σ : Standard deviation

- If $(y - \mu) = \sigma$, then the pdf is down to $\frac{1}{\sqrt{e}} \approx 60\%$
- 68% of all occurrences y are between $\pm\sigma$
- 95% of all occurrences y are between $\pm 2\sigma$
- 99.7% of all occurrences y are between $\pm 3\sigma$
- Careful: This is the amplitude distribution, not the spectrum or function in time

Normal (Gaussian) Distribution (Pictorial)

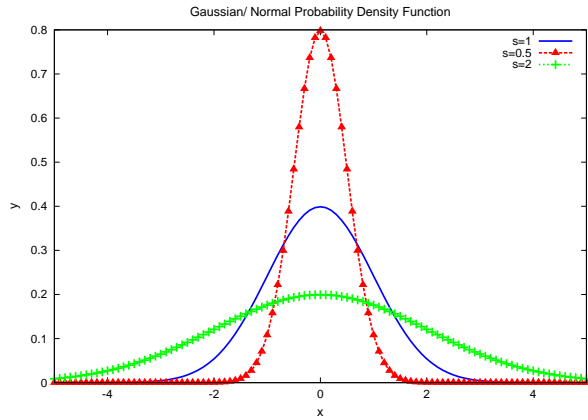

Representation of Gaussian

Probability Function with different standard deviations $\sigma = 0.5; 1; 2$.

Mean, Variance, and Momentums

- Practically even the pdf is almost unusable
- More simplification (with loss of details) is required:

① Average:

$$\mu = \overline{y(t)} = \lim_{T \rightarrow \infty} \frac{1}{2T} \int_{-T}^T y(t) dt$$

for electrical (stochastic) process this will vanish to 0.

- ② Now, use quadratic average. If stoch. value y is the voltage, then the quadratic mean is proportional to the power.

$$\overline{y^2(t)} = \int_{-\infty}^{\infty} y^2(t) dt$$

Physics of Noise

Different physical phenomena will lead to noise:

- Thermal Noise (e.g. resistors, radiation from hot bodies (black bodies))
Happens each and everywhere, in electronics resistive elements are the main source for this.
- Noise from discrete nature of matter (waterfall, electrons at a potential barrier, avalanches)
This is particularly important for semiconductors
- Cosmic noise (actually originating from the big bang)

These are essentially noiseless

- Ideal transmission lines, capacitors, inductors

- RF Basics
- System Overview
- Fields & Waves
- Transmission Lines
- Practical TL
- 2-Port and S-Parameters
- Matching
- Antennas
- Passives
- Transistors
- Linear Amplifier
- Noise

- 12 Noise and Stochastic Processes
 - Noise Basics
 - Thermal Noise**
 - 2-Port-Noise-Figure
 - Noise Temperature and Measurement
 - Chain Formula
- 13 Non-Linearities and Power Amplifiers

Thermal Noise of a Resistor

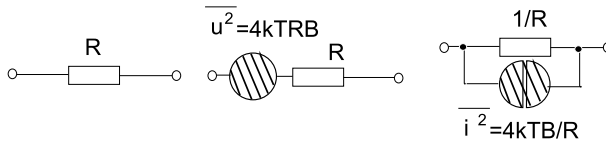

- Experiments and theory show that the equivalent noise power of a resistor is

$$N = kTB.$$

$k = 1.38 \cdot 10^{-23} \text{Ws/K}$ Boltzman's constant, B bandwidth, $T(= 300\text{K})$

temperature. This is valid for moderately low frequency $hf \ll kT$

($h = 6.626 \cdot 10^{-34} \text{ Js}$ Planck's quantum constant)

- Noise voltage source is now characterized by its mean squares

$$\sqrt{\overline{u^2}} = 2\sqrt{kTRB} = 2\sqrt{NR}.$$

- Or the like the current source $\sqrt{\overline{i^2}} = 2\sqrt{kTGB}$. with $G = 1/R$.

Overview of Noise Power and Voltage

Comment	R/Ω	T/K	B	N/W	N/dBm	$\sqrt{u^2}$
Cool	50	70	1 Hz	$9.7 \cdot 10^{-22}$	-180	0.44 nV
Normal	50	300	1 Hz	$4.1 \cdot 10^{-21}$	-174	0.9 nV
Video	75	300	1 Hz	$4.1 \cdot 10^{-21}$	-174	1.1 nV
Narrow	50	300	1 kHz	$4.1 \cdot 10^{-18}$	-144	28 nV
Medium	50	300	1 MHz	$4.1 \cdot 10^{-15}$	-114	900 nV
Broad	50	300	1 GHz	$4.1 \cdot 10^{-12}$	-84	28 μ V
Res.	1M	300	1 MHz	$4.1 \cdot 10^{-15}$	-114	0.13 mV

Examples for noise sources under some example conditions.

Calculating Signal to Noise Ratio

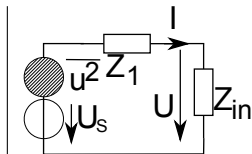

$$U_{Sin} = U_S \frac{Z_{in}}{Z_{in} + Z_1}$$

$$I_{Sin} = U_S \frac{1}{Z_{in} + Z_1}$$

$$S = \text{Re} \{ U_{Sin} I_{Sin}^* \} = |U_S|^2 \frac{\text{Re}\{Z_{in}\}}{|Z_1 + Z_{in}|^2}$$

$$\text{with power } N = \overline{U_1^2} \frac{\text{Re}\{Z_{in}\}}{|Z_1 + Z_{in}|^2}$$

The Signal to Noise Ratio (SNR) is

$$\frac{S}{N} = \frac{|U_S|^2}{U_1^2} = \frac{|U_S|^2}{4kTB\text{Re}\{Z_1\}}$$

the smaller the noise resistor, the better!

Connecting Noisy Sources

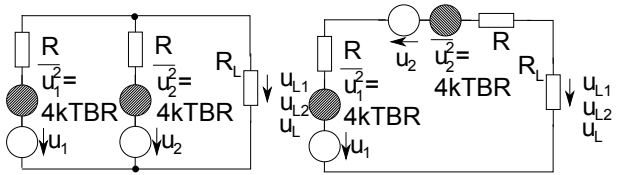

How to

- For uncorrelated noise sources calculate voltages and currents of each individual source (superposition principle). when done add up the power (never the voltages itself) and thus get the resulting power of the desired position.
- For correlated source work as above, and additionally exploit correlation between sources

$$\frac{S}{N} = \begin{cases} \frac{2U^2}{8kTBR}, & \omega_1 \neq \omega_2 \\ \frac{4U^2}{8kTBR}, & \omega_1 = \omega_2 \end{cases}$$



Connecting Noisy Sources

Derivation:

- Assume in general the sources are independent and assume for simplicity impedances are real and $R = R_1 = R_2$. In time-domain we get

$$\begin{aligned}u_{L1}(t) &= u_1(t) \frac{R \parallel R_L}{R + R \parallel R_L} \\ &= u_1(t) \frac{R_L}{R + 2R_L} \quad \text{und} \\ u_{L2}(t) &= u_2(t) \frac{R_L}{R + 2R_L}.\end{aligned}$$

- for harmonic oscillation we have

$$\begin{aligned}u_1(t) &= \sqrt{2}U_1 \cos(\omega_1 t), \\ u_2(t) &= \sqrt{2}U_2 \cos(\omega_2 t)\end{aligned}$$

Connecting Noisy Sources

continued derivation

- Power:

$$\begin{aligned} S &= \overline{(u_1(t) + u_2(t))^2} \frac{R_L}{(R + 2R_L)^2} \\ &= \overline{2(U_1 \cos(\omega_1 t) + U_2 \cos(\omega_2 t))^2} \frac{R_L}{(R + 2R_L)^2} \\ &= \overline{2U_1^2 \cos^2(\omega_1 t) + U_2^2 \cos^2(\omega_2 t) + 2U_1 U_2 \cos(\omega_1 t) \cos(\omega_2 t)} \cdot \\ &\quad \cdot \frac{R_L}{(R + 2R_L)^2} \end{aligned}$$

- Power (average) for harmonic oscillations

$$\overline{u^2(t)} = \lim_{T \rightarrow \infty} \frac{1}{2T} \int_{-T}^T u^2(t) dt.$$

continued...

- Trigonometric addition theorems:

$$\cos(\omega_1 t) \cos(\omega_2 t) = \frac{1}{2} \cos((\omega_1 - \omega_2)t) + \frac{1}{2} \cos((\omega_1 + \omega_2)t),$$

$$\int \cos(\omega t) dt = \frac{1}{\omega} \sin(\omega t),$$

$$\int \cos^2(\omega t) dt = \frac{1}{2}t + \frac{1}{4\omega} \sin(2\omega t),$$

$$\lim_{T \rightarrow \infty} \frac{1}{T} \sin(\omega T) = 0$$

Connecting Noisy Sources

continued...



$$S = \begin{cases} (U_1^2 + U_2^2) \frac{R_L}{(R+2R_L)^2}, & \omega_1 \neq \omega_2 \\ (U_1^2 + U_2^2 + 2U_1U_2) \frac{R_L}{(R+2R_L)^2}, & \omega_1 = \omega_2 \end{cases}$$

- For noise source we have in analogy (superposition principle)

$$u_{Ln1}(t) = u_{n1}(t) \frac{R_L}{(R + 2R_L)^2}$$

$$u_{Ln2}(t) = u_{n2}(t) \frac{R_L}{(R + 2R_L)^2}$$

- And thus the noise power

$$\begin{aligned} N &= \frac{(u_{Ln1}(t) + u_{Ln2}(t))^2}{R_L} \\ &= \frac{(u_{Ln1}^2(t) + u_{Ln2}^2(t) + 2u_{Ln1}(t)u_{Ln2}(t))}{R_L} \end{aligned}$$

Connecting Noisy Sources

continued ...

- And now again: Average, and consider the noise sources as being statistically independent (uncorrelated)

$$N = \left(\sqrt{\overline{U_{LR1}^2}^2} + \sqrt{\overline{U_{LR2}^2}^2} \right) / R_L.$$

$$\begin{aligned} N &= \left(\overline{U_{LR1}^2} + \overline{U_{LR2}^2} \right) / R_L \\ &= \left(\overline{U_{R1}^2} + \overline{U_{R2}^2} \right) \frac{R_L}{(R + 2R_L)^2}. \end{aligned}$$

- And the Signal-to-Noise-Ratio is

$$\frac{S}{N} = \begin{cases} \frac{(U_1^2 + U_2^2)}{U_{R1}^2 + U_{R2}^2}, \omega_1 \neq \omega_2 \\ \frac{(U_1^2 + U_2^2 + 2U_1 U_2)}{U_{R1}^2 + U_{R2}^2}, \omega_1 = \omega_2 \end{cases}$$

Connecting Noisy Sources

continued ...

- Now, for equal voltages $U_1 = U_2 = U$ and using $\overline{U_{R1}^2} = 4kTBR$ for all noise sources we gain

$$\frac{S}{N} = \begin{cases} \frac{2U^2}{8kTBR}, & \omega_1 \neq \omega_2 \\ \frac{4U^2}{8kTBR}, & \omega_1 = \omega_2 \end{cases}$$

More than Thermal Noise

Shot-Noise

- Normal conductor: Energy-transport through electric and magnetic field
- Semiconductor (PN-Junction): Electrons and holes \Rightarrow discrete nature!
- Because of discrete nature there are current impulses (shots), the spectrum is accordingly like $(\sin(x)/x)$
- On average the shot-noise current is $\overline{I_{SN}^2} = 2qIB$, $q = 1.62 \cdot 10^{-19} \text{ As}$, B is the band-width

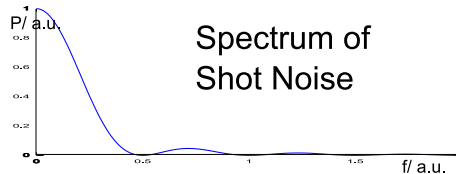

Flicker Noise

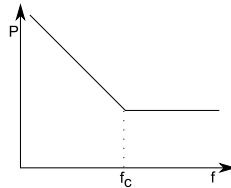

- Not fully (physically) understood, named after spectral behavior ($1/f$)
 - $\overline{i_n^2} = k_F \frac{I^{AF}}{f} B$ with k_F “Flicker Noise Coefficient” and AF “Flicker Noise Exponent” determined from experiment
 - Important: Corner frequency f_c . Bipolar Transistor about 10 kHz, Ga As-FET up to some 100 MHz
- ⇒ FETs bad for oscillator applications, where low frequency components mixed into phase noise.

Noise of an Antenna

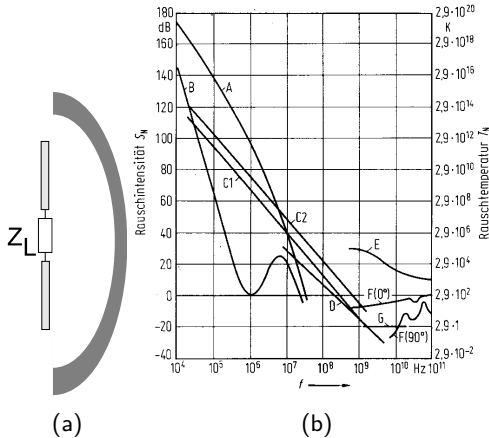

(a) Antenna surrounded by black radiator and (b) Antenna noise after Meinke, Grudlach H17, (A,B) atmospheric (max,min), (C1,C2) industrial (rural,urban), D galactic, E calm sun, F noise of O_2 and H_2 , with 0° and 90° elevation, G radiation of cosmic background, 2.7 K.

Noise of an Antenna

- Man made noise (spark in cars, telephony...)
- Atmospheric noise, mainly from lightnings
- Cosmic noise from deep space
- Thermal noise from atmosphere (O_2 , H_2)
- Thermal noise of any bodies/ material that is in reception direction of the antenna

- Antenna mainly consists of radiation resistor and a voltage source.
- Resistor gets allocated a temperature $T_G = T_S$, which is equal to the temperature of the surrounding T_S , if only thermal noise is present. It is higher, if other sources are present, too.
- If antenna gain is increased, antenna focuses more on wanted signal (amplified by gain). Noise level stays constant, since noise from smaller angle, but with higher gain is received.

2-Port-Noise-Figure

12 Noise and Stochastic Processes

- Noise Basics
- Thermal Noise
- 2-Port-Noise-Figure
- Noise Temperature and Measurement
- Chain Formula

13 Non-Linearities and Power Amplifiers

Noise in Two-Ports - Noise-Figure

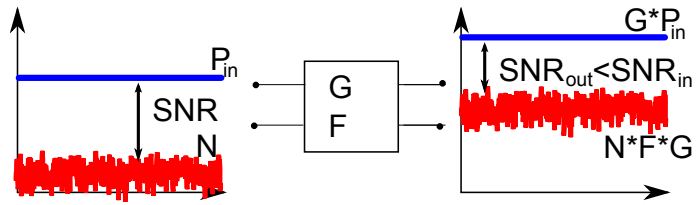

- SNR always gets worse
- Worsening described by Noise Figure F

Noise in Two-Ports - Noise-Figure

- Noise figure defined as ratio between signal-to-noise at input to signal to noise at output: $F = \frac{(S/N)_{input}}{(S/N)_{output}}$
- Usually given in decibel: $F_{dB} = 10 \log(F)$, $F \geq 1$; $F_{dB} \geq 0$
- For 2-port with gain G is $S_{output} = GS_{input}$ and $F = \frac{N_{output}}{GN_{input}}$
- Can be thought of as generated by noise-sources solely at input and then amplified (GN_{zus}): $F = \frac{G(N_{input} + N_{zus})}{GN_{input}} = 1 + \frac{N_{zus}}{N_{input}}$
- Gedanken-experiment: This noise is generated by resistors of equal value as before, but different (higher) temperature T_{eq} . So that we have $F = 1 + \frac{kT_{zus}BR}{kT_0BR} = 1 + \frac{T_{zus}}{T_0}$

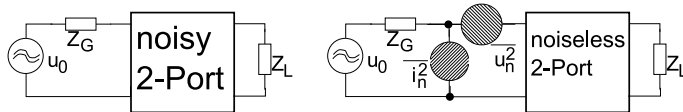

Noise in Active Elements

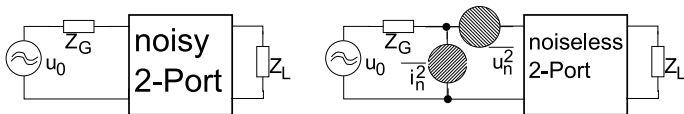

Description also as used in (linear) simulation programs

- Change matrix representation:

$$\begin{bmatrix} U_1 \\ i_1 \end{bmatrix} = \begin{bmatrix} A & B \\ C & D \end{bmatrix} \begin{bmatrix} U_2 \\ i_2 \end{bmatrix} + \begin{bmatrix} u_R(t) \\ i_R(t) \end{bmatrix}$$

- Spectral density of voltage and current source are described as with noise-resistor and -conductance

$$\sqrt{U_R^2(\omega)} = 4kTB R_u$$

$$\sqrt{i_R^2(\omega)} = 4kTB G_i$$

Noise in Active Elements

continued...

Cross-correlation between the two $2(\hat{u}_{xu}(\omega) + j\hat{u}_{xi}(\omega)) = 4kTB(\gamma_u + j\gamma_i)$ and $\gamma_u + j\gamma_i$ is the equivalent noise-impedance

$$u_x^2(\omega) = \int_{-\infty}^{\infty} c(\tau) e^{-j\omega\tau} d\tau$$

$$c(\tau) = \lim_{T \rightarrow \infty} \int_{-T}^T u_1(t) u_2(t + \tau) dt$$

are describing the cross-correlation.

Noise in Active Elements

continued...

Power at input:

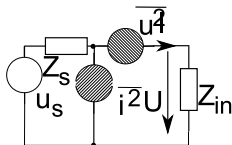

$$\begin{aligned}
 P_{R,in} = \operatorname{Re} \{U I^*\} &= \overline{U_s^2} \frac{R_{in}}{|Z_s + Z_{in}|^2} + \overline{U_R^2} \frac{R_{in}}{|Z_s + Z_{in}|^2} + \overline{i^2} \frac{|Z_s|^2 R_{in}}{|Z_s + Z_{in}|^2} \\
 &\quad + 2 \operatorname{Re} \left\{ (u_{xu} + j u_{xi}) \frac{Z_s^*}{|Z_s + Z_{in}|^2} \right\} \\
 &= 4 k T B \frac{R_s R_{in}}{|Z_s + Z_{in}|^2} \left[1 + \frac{R_u}{R_s} + \frac{G_i}{G_s} + \frac{R_s \gamma_u + X_s \gamma_i}{R_s} \right]; \\
 G_s &= \frac{R_s}{R_s^2 + X_s^2} = \frac{R_s}{|Z_s^2|}
 \end{aligned}$$

Output power is just multiplication with $G(u)$.

Noise in Active Elements

continued...

Noise Figure:

$$F = \frac{\frac{S}{N} \text{ at input}}{\frac{S}{N} \text{ at output}}$$

Because in our thought experiment the amplifying 2-port is noiseless, we only need to check the input:

$$F = \frac{\text{Total noise power at input}}{\text{Thermal noise power from source}}$$

And then

$$F = 1 + \frac{R_u}{R_s} + \frac{G_u}{G_s} + \frac{R_s \gamma_s + X_s \gamma_i}{R_s} = 1 + (R_u + 2 X_s \gamma_i) \frac{1}{R_s} + 2 \gamma_s + G_i R_s + \frac{G_i X_s^2}{R_s}$$

continued...

Minimum noise (noise matching)

$$\frac{\partial F}{\partial R_s} = 0 \quad ; \quad \frac{\partial F}{\partial X_s} = 0$$

$$\text{hence } 0 = -\frac{R_u 2 X_s \gamma_i}{R_s^2} - G_i + \frac{G_i X_s^2}{R_s^2}$$

$$\text{and } 0 = 2\frac{\gamma_i}{R_s} + 2G_i \frac{X_s}{R_s} \Leftrightarrow X_m = -\frac{\gamma_i}{G_i}$$

$$\Leftrightarrow G_i R_s^2 = R_u + 2X_s \gamma_i + G_i X_s^2 = R_u - 2G_i X_{sm}^2 + G_i X_{sm}^2$$

$$\Leftrightarrow R_s^2 + X_s^2 = \frac{R_u}{G_i} \quad \text{thus} \quad R_m = \sqrt{\frac{R_u}{G_i} - \frac{\gamma_i^2}{G_i^2}}$$

Noise matching \neq power (conjugate) matching

continued...

- Noise figure as deviation from minimum noise

$$\begin{aligned}\gamma_i &= -X_m G_i \\ F - F_m &= \frac{1}{R_s} [R_u + (R_s^2 + X_s^2) G_i - 2 X_m X_s G_i] \\ &\quad - \frac{1}{R_s} [R_u + (R_s^2 + X_s^2) G_i - 2 X_m^2 G_i]\end{aligned}$$

- And finally

$$F = F_m + \frac{G_i}{R_s} [(R_s - R_m)^2 + (X_s - X_m)^2]$$

Noise Temperature and Measurement

- RF Basics
- System Overview
- Fields & Waves
- Transmission Lines
- Practical TL
- 2-Port and S-Parameters
- Matching
- Antennas
- Passives
- Transistors
- Linear Amplifier
- Noise

- 12 Noise and Stochastic Processes
 - Noise Basics
 - Thermal Noise
 - 2-Port-Noise-Figure
 - Noise Temperature and Measurement**
 - Chain Formula
- 13 Non-Linearities and Power Amplifiers

Equivalent Noise Temperature

Noise of an arbitrary noisy 1-port: It's all in the temperature

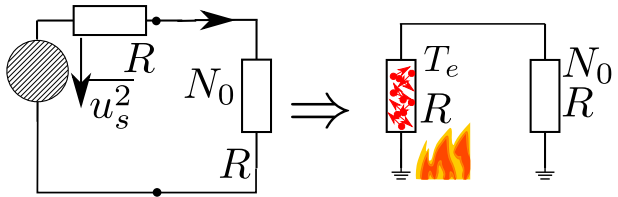

$$T_e = \frac{N_0}{kB}$$

no physical temperature, but model

Equivalent Noise Temperature

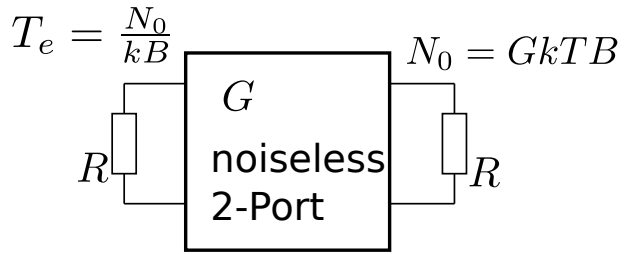
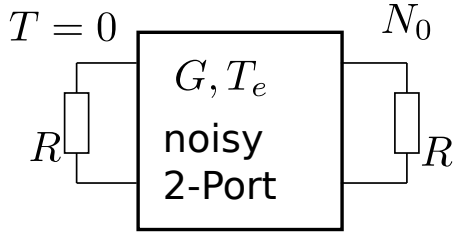

- Put it all in the temperature at input

Noise Figure and Temperature

- Noiseless: $N_{out} = GkTB$
- Noisy: $N'_{out} = GkT_e B + GkTB$
- Signal: $S_{Out} = GS_{in}$
- Noise Figure:

$$F = \frac{S_{out}}{N_{out}} \times \frac{N'_{out}}{S_{out}} = \frac{GkB(T + T_e)}{GkTB} = 1 + \frac{T_e}{T}$$

- Noise Temperature: $T_e = T(F - 1)$

Naive approach

- ① Measure Gain: G
- ② Measure Noise power at output with matched input:

$$N'_{out} = G(N_{in} + N_{add}) = GkBT(T + T_e)$$

- ③ Calculate $T_e = \frac{N'_{out}}{GkB} - T$

Inaccurate, if Gain measured narrow band (CW-signal) and with high power, only advised for very noisy circuits and with no budget.

Official noise measurement technique

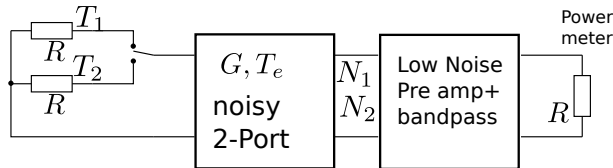

- $T_2 \gg T_1$ (maybe 16 dB)
- $N_1 = GkT_1B + GkT_eB$ $N_2 = GkT_2B + GkT_eB$
- $Y = \frac{N_2}{N_1} = \frac{T_2 + T_e}{T_1 + T_e}$
- $T_e = \frac{T_1 - YT_2}{Y - 1}$

Noise source usually active device (e.g. avalanche diode)

Low noise amp practically VERY important (do not try this with plain spectrum analyzer)

- RF Basics
- System Overview
- Fields & Waves
- Transmission Lines
- Practical TL
- 2-Port and S-Parameters
- Matching
- Antennas
- Passives
- Transistors
- Linear Amplifier
- Noise

12 Noise and Stochastic Processes

- Noise Basics
- Thermal Noise
- 2-Port-Noise-Figure
- Noise Temperature and Measurement
- Chain Formula

13 Non-Linearities and Power Amplifiers

Noise Figure of Chains

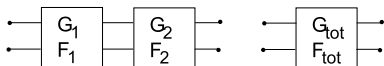

- Available noise power at output of 2nd 2-port $N_2 = F_{12}G_1G_2kTB$
- Noise power of 2-port 1 at output of 2-port 2 $N_{21} = F_1G_1G_2kTB$
- Contribution of 2-port 2 $N_{22} = (F_2 - 1)G_2kTB$
- And in total

$$\begin{aligned} N_2 = N_{21} + N_{22} &= kTB(F_1G_1G_2 + (F_2 - 1)G_2) \\ &= kTBG_1G_2\left(F_1 + \frac{F_2 - 1}{G_1}\right) \end{aligned}$$

- Chain equation for noisy 2-ports

$$F_{12} = F_1 + \frac{F_2 - 1}{G_1}$$

$$G_{12} = G_1G_2$$

References

Non-Linearities and Power Amplifiers

- 11 Amplifier: Linear and Design with S-Parameters
- 12 Noise and Stochastic Processes
- 13 Non-Linearities and Power Amplifiers**
- 14 Power Amplifiers
- 15 Mixers for Frequency Translation
- 16 Radar Introduction

What you Should Know after this Session

- See simple non-linearities
- Learn how they disturb your signal, or make it even impossible to receive it
- Design (approximate) systems regarding there non-linear behavior
- Calculate with intercept points
- Know classes of power amplifiers and comment on them

Linear Amplifiers

- RF Basics
- System Overview
- Fields & Waves
- Transmission Lines
- Practical TL
- 2-Port and S-Parameters
- Matching
- Antennas
- Passives
- Transistors
- Linear Amplifier
- Noise

13 Non-Linearities and Power Amplifiers

- Linear Amplifiers
- Intermodulation
- Intercept Points
- Chain Formulas

14 Power Amplifiers

Linear Amplifiers

So far we have only considered amplifiers that are (infinitely) linear, maybe a little bit noisy. This is not how the world is! At a certain (input) power all devices become non-linear. In the most extreme case they just blow up or start burning. Thus, we need to deal with non-linearity.

- Non-Linearity, which is also signal distortion, need to be considered for power amplifiers (PA) and in modern communication systems also in LNA.

Linear Amplifiers

- LNA linearity is an issue because of the high dynamic ranges which stem from
 - Coexistence of different standards
 - Coexistence and co-siting of different senders and receivers (base-stations)
 - High distance to transceiver requirements
 - complex modulation
- For power amplifiers (PA) most of the above is important, and
 - Efficiency: Energy must be utilized in best possible way. This is especially true, but not limited to, for mobile-devices
 - Thermal conditions (cooling), which means cost, life-time, space, serviceability

Non-linear Distortions

Before going into efficiency and amplifier design, let's look at non-linearities more closely

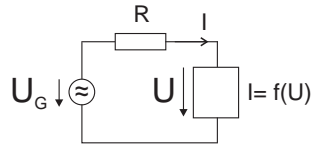

- $f(U)$ is a non-linear element, whose characteristic at the operating point can be expressed as a Taylor-series (memory less)

$$I = f(U) = i_0 + a_1 U + a_2 U^2 + a_3 U^3 + \dots$$

- Consider excitation with a two-frequency-signal

$$U_G = U_1 \cdot \cos(\omega_1 t) + U_2 \cdot \cos(\omega_2 t)$$

- See mixing terms for $R = 0$ on the following slides

NL: Frequency Mixing 1 & 2

- Linear $i_1(t) = a_1 U_G = a_1 U_1 \cos(\omega_1 t) + a_1 U_2 \cos(\omega_2 t)$
- Quadratic

$$\begin{aligned} i_2(t) &= a_2 U_G^2 \\ &= \frac{1}{2} a_2 \{ U_1^2 + U_2^2 + U_1^2 \cos(2\omega_1 t) + U_2^2 \cos(2\omega_2 t) + \\ &\quad + 2U_1 U_2 [\cos((\omega_1 + \omega_2)t) + \cos((\omega_1 - \omega_2)t)] \} \end{aligned}$$

- Finally the Cubic part:

$$\begin{aligned}
 i_3(t) &= a_3 U_G^3 \\
 &= \frac{1}{4} a_3 \{ U_1^3 \cos(3\omega_1 t) + U_2^3 \cos(3\omega_2 t) \\
 &\quad + 3U_1^2 U_2 [\cos((2\omega_1 + \omega_2)t) + \cos((2\omega_1 - \omega_2)t)] \\
 &\quad + 3U_2^2 U_1 [\cos((2\omega_2 + \omega_1)t) + \cos((2\omega_2 - \omega_1)t)] \\
 &\quad + 3(U_1^3 + 2U_2^2 U_1) \cos(\omega_1 t) \\
 &\quad + 3(U_2^3 + 2U_1^2 U_2) \cos(\omega_2 t) \}
 \end{aligned}$$

- Total current is $I = i_0 + i_1(t) + i_2(t) + i_3(t)$

Signal Distortion

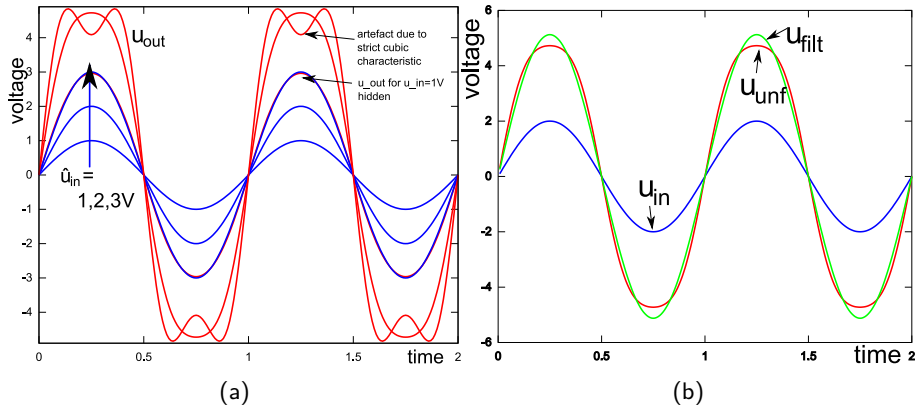

Signal distortion in the time domain for cubic characteristic $u_{out}(t) = \sqrt{10}u_{in}(t) - 0.2u_{in}^3(t)$ for (a) different input voltages and (b) 2V peak-voltage at input and additionally (ideally) low-pass filtered output voltage.

- Note the distortion of the signal

The Spectrum

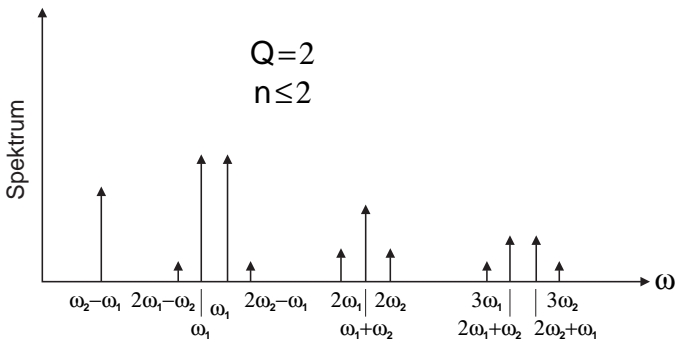

Mixing of two signals (ω_1, ω_2) (schematically)

- Generally $|m| + |n|$ defines the order of the non-linearity

Increase the Power

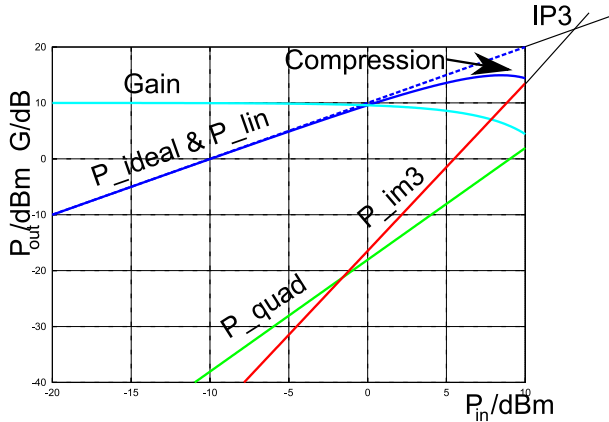

Different power output signals at the amplifier for characteristic

$$u_{out}(t) = \sqrt{10}u_{in}(t) - 0.5u_{in}^2(t) - 0.2u_{in}^3(t). \text{ (Quadratic term can be omitted completely, the picture only changes so that the corresponding line vanishes)}$$

The Spectrum... It's real

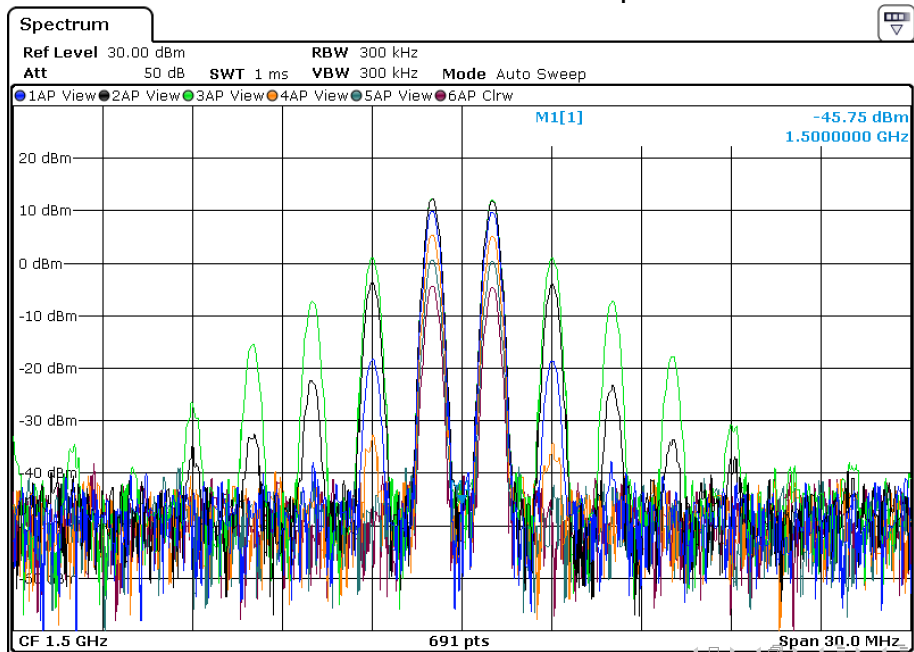

NL: Sorted by Frequency

$(n)\omega_1$	$(m)\omega_2$	Spectral component (I_{tot})	Use
0	0	$a_0 + a_2/2 U_1^2 + a_2/2 U_2^2$	DC \propto Power
0	1	$a_1 U_2 + 3/2 a_3 U_2 (U_1^2 + U_2^2/2)$	Signal 2
0	2	$a_2/2 U_2^2$	Doubler
0	3	$a_3/4 U_2^3$	Tripler
1	-2	$3/4 a_3 U_1 U_2^2$	IM3
1	-1	$a_2 U_1 U_2$	Mixer (down)
1	0	$a_1 U_1 + 3/2 a_3 U_1 (U_2^2 + U_1^2/2)$	Signal 1
1	1	$a_2 U_1 U_2$	Mixer (up)
1	2	$3/4 a_3 U_1 U_2^2$	Mixer (subharm)
2	-1	$3/4 a_3 U_1^2 U_2$	IM3
2	0	$a_2/2 U_1^2$	Doubler
2	1	$3/4 a_3 U_1^2 U_2$	Mixer (subharm.)
3	0	$a_3/4 U_1^3$	Tripler

Harmonic Frequencies

- Frequencies at $m\omega_1, n\omega_2$
- Not always a problem, because far off band and so can be filtered out.
- **Careful: Sometimes at also harmonic resonances of filters! So design the filter carefully**
- Technically used in frequency multipliers (doublers and tripler). Especially important for very high frequency applications (automotive radar at 75 GHz)

13 Non-Linearities and Power Amplifiers

- Linear Amplifiers
- Intermodulation
- Intercept Points
- Chain Formulas

14 Power Amplifiers

Inter-modulation

- Mixing of two or more signals
- Third order intermod at $2\omega_1 - \omega_2$ and $2\omega_2 - \omega_1$
- Fifth order intermod (not explicitly calculated) at $3\omega_1 - 2\omega_2$, $3\omega_2 - 2\omega_1$ increasingly interesting, when third order is successfully combated, and in complex modulation schemes
- IM3 usually very disturbing, because very close to or in desired band. Thus, cannot easily be filtered.
- IM3 can blind a receiver (small signal cannot be detected in presence of two higher-power signal)
- IM3 in transmitter can disturb adjacent (undesired) channels/ bands

Saturation/ Compression/ Blocking

- Gain is reduced with increasing input power. This requires, that $a_3 < 0$ (> 0 would not make sense at all).
- ω_1 -component: $i_1(t) = (a_1 U_1 + \frac{3}{4} a_3 U_1^3) \cos(\omega_1 t)$
- Blocker-Effect: The gain for a small signal U_2 is greatly reduced in the presence of a large signal (blocker) U_1 : $U_1 \gg U_2$

$$i_1(t) = \left[a_1 U_2 + \frac{3}{4} a_3 (U_2^3 + 2U_1^2 U_2) \right] \cos(\omega_2 t)$$

$$\approx \left(a_1 + \frac{3}{2} a_3 U_1^2 \right) U_2 \cos(\omega_2 t)$$

$\frac{3}{2} a_3 U_1^2$ reduces gain for small signal U_2

This may reduce sensitivity of the small signal so that it cannot be received and detected properly.

Cross-Modulation

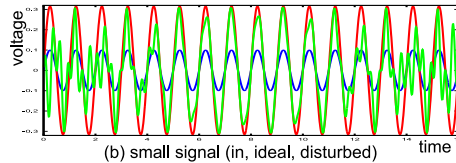
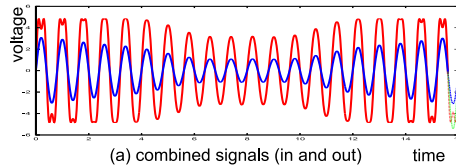

Cubic characteristic and excitation with $u_{in} = 0.1 V \sin(2\pi t) + 2(1 + 0.5 \cos(\pi/8t)) \sin(2.5\pi t)$

- (a) shows the complete and combined signal at in and output, the modulation can be noted
- (b) is an artificial extraction of only the small signal. Note how much the small signal is destroyed by the modulation of the large one

We have seen before that the modulation on a large signals influences a smaller one:

- Input signal $U_{in} = U_1 \cos(\omega_1 t) + [1 + m(t)]U_2 \cos(\omega_2 t)$ with modulation $m(t)$, ($\max \{m(t)\} < 1$)
- This fires back into component number 1 like:
 $i'_3(t) = \frac{3}{2}a_3 U_1 U_2^2 [1 + 2m(t) + m^2(t)] \cos(\omega_1 t)$ and is quiet critical if U_2 is large.

Intercept Points

- RF Basics
- System Overview
- Fields & Waves
- Transmission Lines
- Practical TL
- 2-Port and S-Parameters
- Matching
- Antennas
- Passives
- Transistors
- Linear Amplifier
- Noise

13 Non-Linearities and Power Amplifiers

- Linear Amplifiers
- Intermodulation
- **Intercept Points**
- Chain Formulas

14 Power Amplifiers

Intercept-Point of Second Order (IP2)

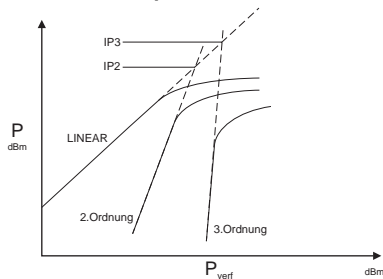

Definition of intercept-points

- This is purely virtual: **The intercept point is the intersection of (extrapolated) harmonic power with (extrapolated) ideal linear output power.**

- Second Harmonic, 1-tone-excitation

$$I|_{\omega_1} = I|_{2\omega_1} \Leftrightarrow a_1 U_{1IP2} = \frac{a_2}{2} U_{1IP2}^2 \Leftrightarrow U_{1IP2} = 2 \frac{a_1}{a_2}$$

- Second Harmonic, 2-tone-excitation

$$I|_{\omega_1} = I|_{\omega_1+\omega_2} \Leftrightarrow a_1 U_{1IP2} = a_2 U_{1IP2} U_{2IP2} \Leftrightarrow U_{1IP2} = \frac{a_1}{a_2}$$

Intercept-Point of Third Order

- Compare component at ω_1 with component at $2\omega_1 - \omega_2$:

$I|_{\omega_1} = I|_{2\omega_1 - \omega_2} \Leftrightarrow a_1 U_{1IP3} = \frac{3}{4} |a_3| U_{1IP3}^2 U_{2IP3}$ with 2 tones of equal amplitude:

$$U_1 = U_2 : \Leftrightarrow U_{1IP3} = \sqrt{\frac{4}{3} \frac{a_1}{|a_3|}} = k$$

- Usually this is given for power rather than voltages and so in a 50Ω -System

$$P_{IP3} = \frac{|U_{1IP3}|^2}{2Z_0} = \frac{k^2}{2Z_0} = IIP3$$

- What we have above is the IP3 x-axis (i.e. related to the input power) for amplifiers usually the OIP3 (related to the output power) is given. This can easily be obtained by $OIP3 = G_p IIP3$
- In data-sheets you will usually find always the larger number for IP3, that is OIP3 for amps, but IIP3 for mixers (that have loss rather than gain)

Intercept and Compression

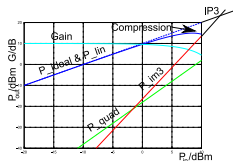

- Strong connection between compression and intercept-point (cubic approximation).
- For compression of c we have: $a_1 U_{1c} = \frac{3}{4} U_{1c}^3 = c a_1 U_{1c} \Leftrightarrow U_{1c} = \sqrt{\frac{1-c}{\frac{3}{4} \frac{|a_3|}{a_1}}} = \sqrt{1-c} k$
- So for $c|_{dB} = -1dB$, hence $c = 10^{-1/20} = 0.89125$ and thus $\sqrt{1-c} = 0.32977 \hat{=} 20 \log(\sqrt{1-c}) = -9.636dB$.
- Rule of thumb: 1 dB-Compression is 9-10 dB below the Interceptpoint of third order.
- Similar the 3 dB-Compression is about 5 dB below IP3

Calculation with Intercept Points

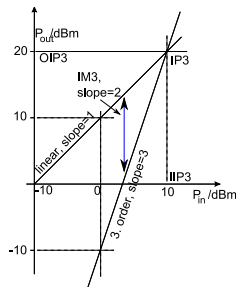

- For third order intermodulation-distance: $IMD_3 = P_{lin} - P_{IM3}$
- Linear power at output $P_{lin} = P_{in} + G$
- 3rd order power at output

$$P_{IM3} = OIP_3 + 3(P_{in} - IIP_3) = IIP_3 + G + 3(P_{in} - IIP_3)$$
- And so $IMD_3 = P_{lin} - P_{IM3} = 2(IIP_3 - P_{in})$

Chain Formula for Intercept-Points I

Wouldn't it be nice to have a chain formula for the non-linearity as we have it already for the noise? If so we could (roughly) calculate a full system with gain (linear), noise (sensitivity), and non-linearity (max power).

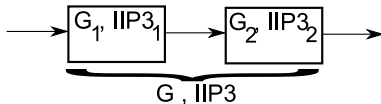

Good news: There is:

- Output of amp (distorer) (k is IIP3 for voltage so: $IIP3 = k^2 / (2Z_0)$)
- The cubic coefficient for voltage-conversion is shortened by $g/c = k^2$, this is

$$c = \frac{3}{4} a_3 Z_0$$

Chain Formula for Intercept-Points II

- At output of first distorter: $U_1 = g_1 U_0$, $U'_1 = c_1 U_0^3 = \frac{1}{k_1^2} U_0^3$
- At output of second distorter:

$$\begin{aligned}U_2 &= g_2 U_1 = g_1 g_2 U_0 \\U'_2 &= c_2 U_1^3 + g_2 U'_1 = (c_2 g_1 + g_2 c_1) U_0^3 \\&= \left(\frac{g_1^3 g_2}{k_2^2} + \frac{g_2 g_1}{k_1^2} \right) U_0^3 \\&= \frac{g_1 g_2}{k_{12}^2} U_0^3\end{aligned}$$

- An so $\frac{1}{k_{12}^2} = \frac{g_1^2}{k_2^2} + \frac{1}{k_1^2}$
- With $G_p = \frac{g_1^2}{2Z_0}$ to come back to powers finally there is

$$\frac{1}{IIP3_{12}} = \frac{G_1}{IIP3_2} + \frac{1}{IIP3_1} .$$

Which is the desired chain formula (again: only an approximation!)

13 Non-Linearities and Power Amplifiers

- Linear Amplifiers
- Intermodulation
- Intercept Points
- **Chain Formulas**

14 Power Amplifiers

Chain Formulas

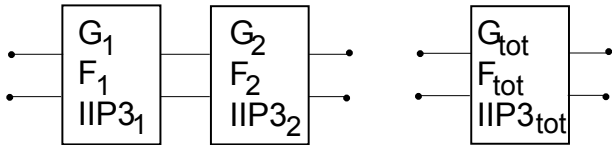

- Gain $G_{tot} = G_1 \cdot G_2$
- Noise $F_{tot} = F_1 + \frac{F_2 - 1}{G_1}$
- (Input) Intercept-Point of Third Order $\frac{1}{IIP3_{tot}} = \frac{G_1}{IIP3_2} + \frac{1}{IIP3_1}$

Optimize Constant Gain Chain

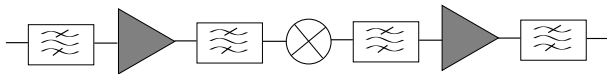

- Optimize structure (not all BP are necessarily required!) Gain/ NF/ IP3 for
- Total Gain 40 dB
- $P_{in,min} = -100$ dBm, $BW = 1$ MHz
- $P_{out,max} = -30$ dBm, $BW = 1$ MHz

Use of Excel-Sheet recommended

Effects on Modulated Signals

- RF Basics
- System Overview
- Fields & Waves
- Transmission Lines
- Practical TL
- 2-Port and S-Parameters
- Matching
- Antennas
- Passives
- Transistors
- Linear Amplifier
- Noise

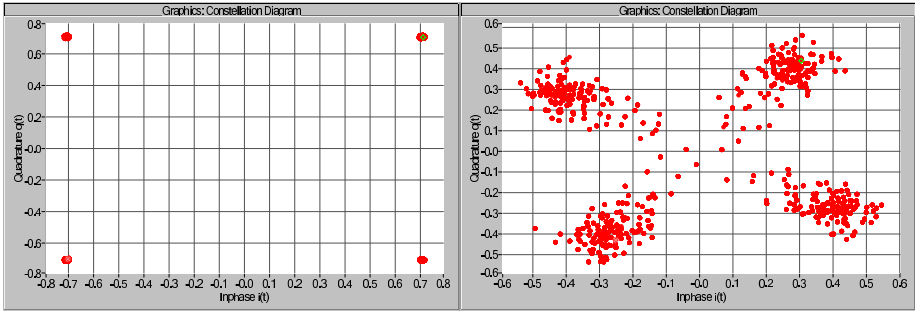

(a)

(b)

Digitally modulated (QPSK) signal (a) undisturbed, (b) through PA
AMAM-AMPM conversion

Power Amplifiers

- RF Basics
- System Overview
- Fields & Waves
- Transmission Lines
- Practical TL
- 2-Port and S-Parameters
- Matching
- Antennas
- Passives
- Transistors
- Linear Amplifier
- Noise
- Linearities

- 12 Noise and Stochastic Processes
- 13 Non-Linearities and Power Amplifiers
- 14 Power Amplifiers**
- 15 Mixers for Frequency Translation
- 16 Radar Introduction
- 17 Oscillators

14 Power Amplifiers

- Classes A,B,C
- Switching Amplifiers

15 Mixers for Frequency Translation

Goal for Power-Amplifiers

- Good enough gain
- High efficiency (observe definition)
- Low (inband) signal distortion
- Low (outband) distortions
- Low build-up of heat
- (and of course: Stability, insensitivity to temp (and other) drifts)

How to achieve that:

- Filter (or load tanks) \Rightarrow this goes distortions
- Only switch the transistor on, when RF signal peaks \Rightarrow avoid any DC pass through transistor

Efficiency usually is

$$\eta = \frac{P_{out}}{P_{DC}}$$

In case of power amps (where the amp has considerable input power and can have small gain) Power Added Efficiency is better suited

$$\text{PAE} = \frac{P_{out} - P_{in}}{P_{DC}}$$

PA Classes ABC

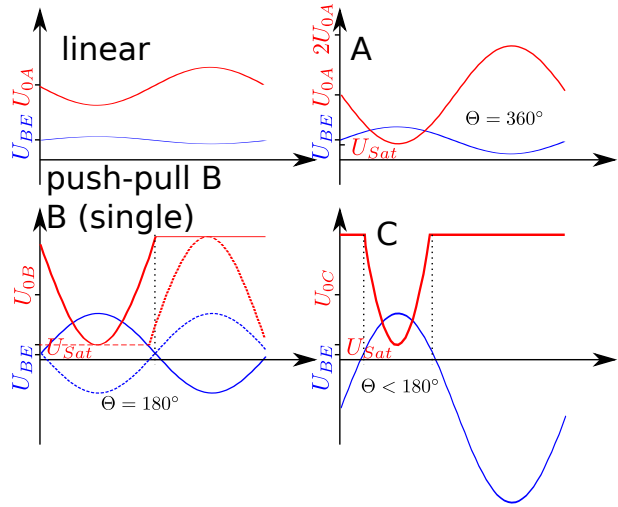

Base-Emitter (Gate-Source) drive specifies the PA-Class

PA-Classes Explained: Class A

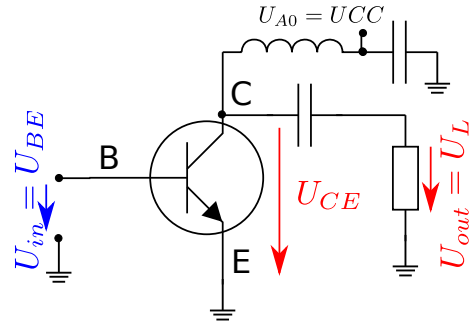

- Full Sine- wave is amplified
- transistor is driven to the edges (all other same as linear amplifier)
- Theoretical efficiency: 50 %
- Still good linearity, No harmonic filter required (for mild requirements)

PA-Classes Explained: Class B

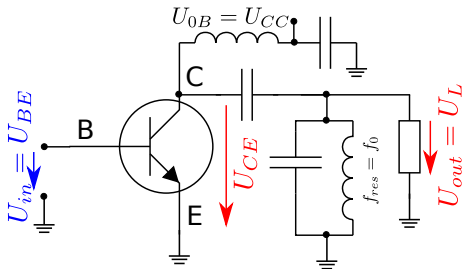

- Class-B: Only one half of sine is amplified \Rightarrow Conduction Angle $\Theta = 180^\circ$
- Theoretical Efficiency: 78 %
- Nonlinear, filter required for harmonics suppression

PA-Classes Explained: Class B Push Pull

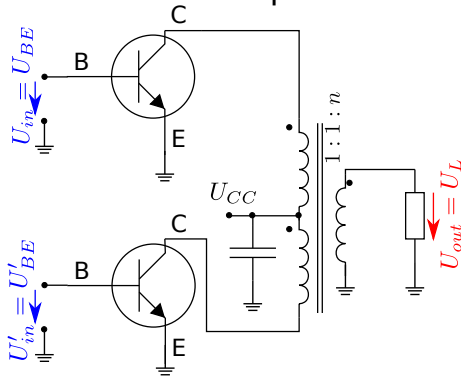

- One half is amplified by first transistor other half by second
- Requires two transistors and transformer (iron in circuit!) \Rightarrow Conduction Angle $\Theta = 180^\circ$ per transistor
- Theoretical Efficiency: 78%
- Good linearity, no harmonics filter (for mild requirements)

PA-Classes Explained: Class C

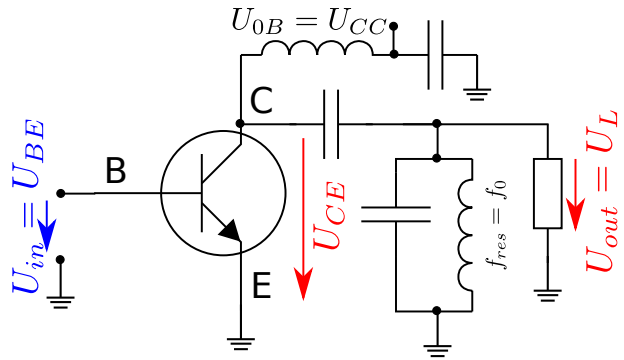

- Same Circuit as Class-B but only peak of sine-wave is amplified ($\Theta < 180^\circ$)
- Theoretical Efficiency up to 100 %
- Highly nonlinear, Harmonics filter required, basically not useable for AM-signals
- Workhorse for FM-Modulation (e.g. GSM)

Loadlines

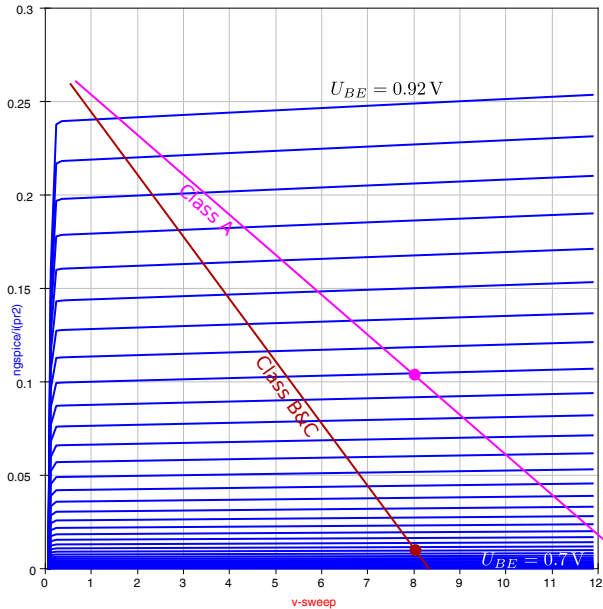

PA-Classes: Theory I

- RF Basics
- System Overview
- Fields & Waves
- Transmission Lines
- Practical TL
- 2-Port and S-Parameters
- Matching
- Antennas
- Passives
- Transistors
- Linear Amplifier
- Noise

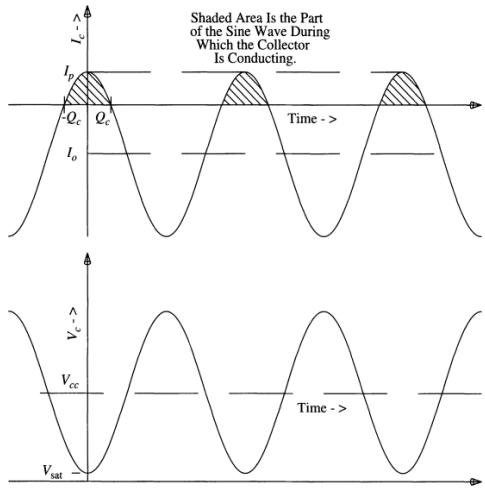

Figure 7.8 Voltage and current waveforms for Figure 7.7. [R. Weber, *Microwave Engineering Course Notes*, ©1987–1997, August 1997 edition, p. 68.]

$$I_c = I_0 + (I_p - I_0) \cos(\Theta); \quad \Theta_c < \Theta < \Theta_c$$

$$U_c = U_{CC} - (U_{CC} - U_{sat}) \cos(\Theta) = U_{CC} - (I_0 - I_p)R_{LL} \cos(\Theta)$$

with R_{LL} the load line resistance.

Zero of current determines Θ_c

$$\cos\left(\frac{\Theta_c}{2}\right) = \frac{I_0}{I_0 - I_p}$$

$$U_c = U_{CC} + \frac{I_0 R_{LL}}{\cos\left(\frac{\Theta_c}{2}\right)} \cos \Theta$$

$$= U_{CC} + \frac{I_p R_{LL}}{1 - \cos\left(\frac{\Theta_c}{2}\right)} \cos \Theta$$

For calculation of DC-Power get the average of the current into the collector

$$\begin{aligned}
 I_{dc} &= \frac{1}{2\pi} \int_{-\Theta_c/2}^{\Theta_c/2} I_0 + (I_p - I_0) \cos(\Theta) d\Theta \\
 &= \frac{I_p}{2\pi} \int_{-\Theta_c/2}^{\Theta_c/2} \left[\frac{\cos\left(\frac{\Theta_c}{2}\right)}{1 - \cos\left(\frac{\Theta_c}{2}\right)} - \frac{\cos\Theta}{\cos\left(\frac{\Theta_c}{2}\right)} d\Theta \right] \\
 &= \frac{I_p \Theta_c}{2\pi \left[1 - \cos\left(\frac{\Theta_c}{2}\right)\right]} \left[\frac{\sin\left(\frac{\Theta_c}{2}\right)}{\frac{\Theta_c}{2}} - \cos\left(\frac{\Theta_c}{2}\right) \right]
 \end{aligned}$$

and the DC-Power is

$$P_{dc} = \frac{U_{CC} I_p \Theta_c}{\pi} \frac{\sin\left(\frac{\Theta_c}{2}\right) - \frac{\Theta_c}{2} \cos\left(\frac{\Theta_c}{2}\right)}{1 - \cos\left(\frac{\Theta_c}{2}\right)}$$

And now the RF-Power. The interesting first harmonic is

$$\begin{aligned}
 I_{RF} &= \frac{1}{\pi} \int_{-\Theta_c/2}^{\Theta_c/2} [I_0 + (I_p - I_0) \cos(\Theta)] \cos \Theta d\Theta \\
 &= \frac{I_p}{2\pi} \frac{\Theta_c - \sin \Theta_c}{1 - \cos\left(\frac{\Theta_c}{2}\right)}
 \end{aligned}$$

The voltage at a purely linear ohmic load is thus

$$\begin{aligned}
 U_{RL} &= \frac{-I_p R_L}{2\pi} \frac{\Theta_c - \sin \Theta_c}{1 - \cos\left(\frac{\Theta_c}{2}\right)} \\
 &= -(U_{CC} - U_{sat}) \cos \Theta_c
 \end{aligned}$$

And the Power ($P = \hat{u}\hat{i}/2$)

$$P_{RF} = \frac{(U_{CC} - U_{sat})I_p \cos \Theta_c}{2\pi} \frac{\Theta_c - \sin \Theta_c}{1 - \cos \left(\frac{\Theta_c}{2}\right)}$$

and the (theoretical) load resistance

$$R_L = \frac{2\pi(U_{CC} - U_{sat}) \left[\cos \left(\frac{\Theta_c}{2}\right)\right]}{I_P [\Theta_c - \sin \Theta_c]}$$

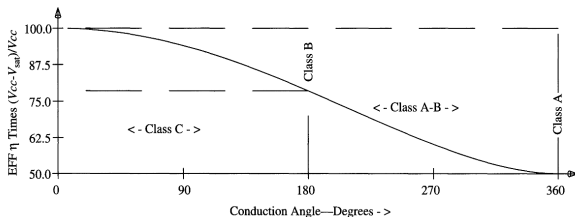
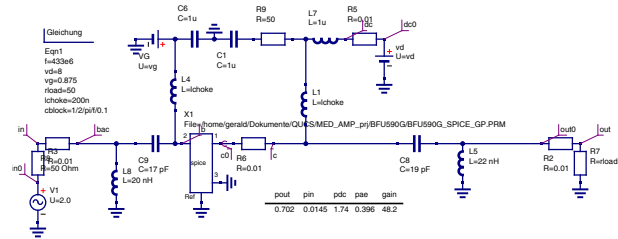

Figure 7.9 Efficiency vs. device conduction angle. [Adapted from Solid State Radio Engineering, H. L. Krauss, C. W. Bostian, and F. H. Raab, Copyright ©1980, John Wiley & Sons, Inc. Reprinted by permission of John Wiley & Sons, Inc.]

And the (theoretical) efficiency is

$$\eta = \frac{U_{CC} - U_{sat}}{2U_{CC}} \frac{\Theta_c - \sin \Theta_c}{2 \sin \left(\frac{\Theta_c}{2} \right) - \Theta_c \cos \left(\frac{\Theta_c}{2} \right)}$$

Simulations Results: Class A



Schematic for Class-A amplifier based on NXP's BFU590G BJT

Simulations Results: Class A

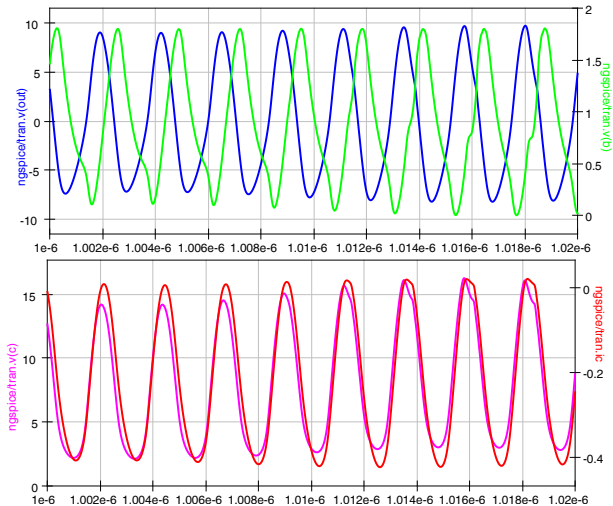

$$P_{out} = 0.70 \text{ W}, \text{ PAE} = 40 \%$$

$$P_{dc} = 1.7 \text{ W}, P_{in} = 15 \text{ mW}, G = 17 \text{ dB}$$

Simulations Results: Class B

- RF Basics
- System Overview
- Fields & Waves
- Transmission Lines
- Practical TL
- 2-Port and S-Parameters
- Matching
- Antennas
- Passives
- Transistors
- Linear Amplifier
- Noise

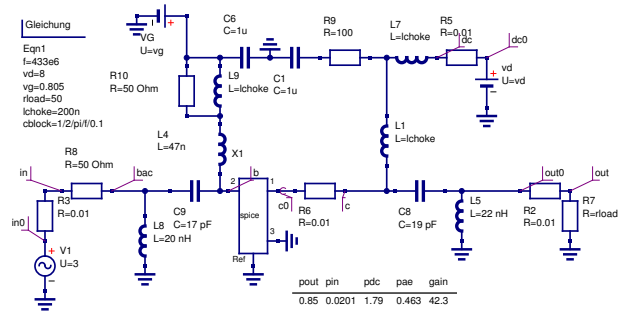

Schematic for Class-B amplifier based on NXP's BJT

Simulations Results: Class B

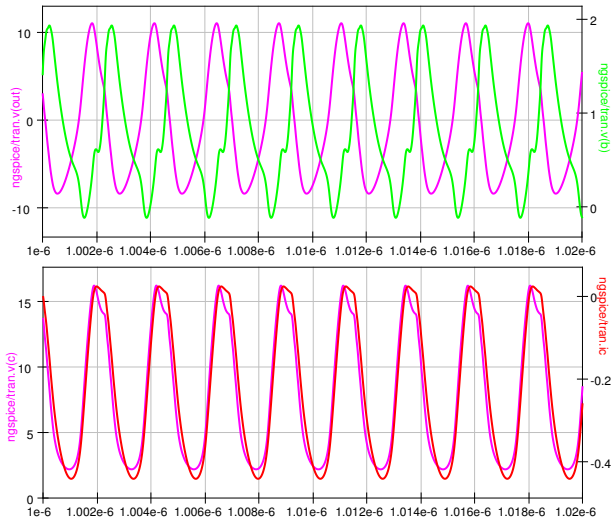

$$P_{out} = 0.85 \text{ W}, \text{ PAE} = 46 \%$$

$$P_{dc} = 1.8 \text{ W}, P_{in} = 20 \text{ mW}, G = 16 \text{ dB}$$

Simulations Results: Class B - Push Pull

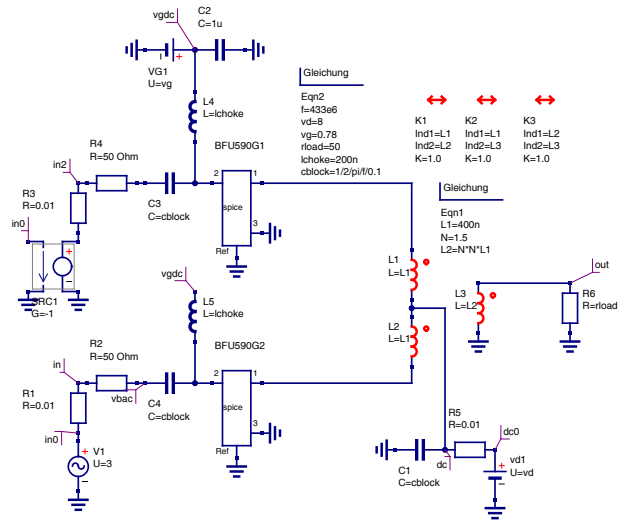

Simulations Results: Class B - Push Pull

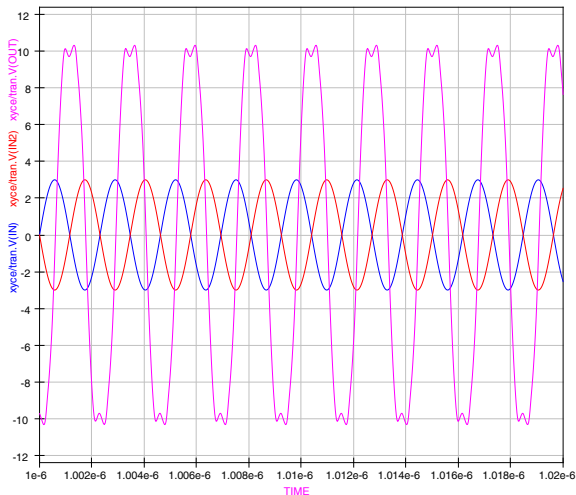

$$P_{out} = 1.32 \text{ W}, \text{ PAE} = 44 \%$$

$$P_{dc} = 2.9 \text{ W}, P_{in} = 24 \text{ mW}, G = 17 \text{ dB}$$

Simulations Results: Class C

- RF Basics
- System Overview
- Fields & Waves
- Transmission Lines
- Practical TL
- 2-Port and S-Parameters
- Matching
- Antennas
- Passives
- Transistors
- Linear Amplifier
- Noise

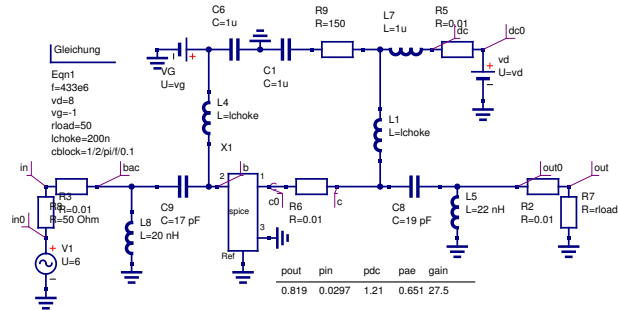

Schematic for Class-C amplifier based on NXP's BJT

Simulations Results: Class C

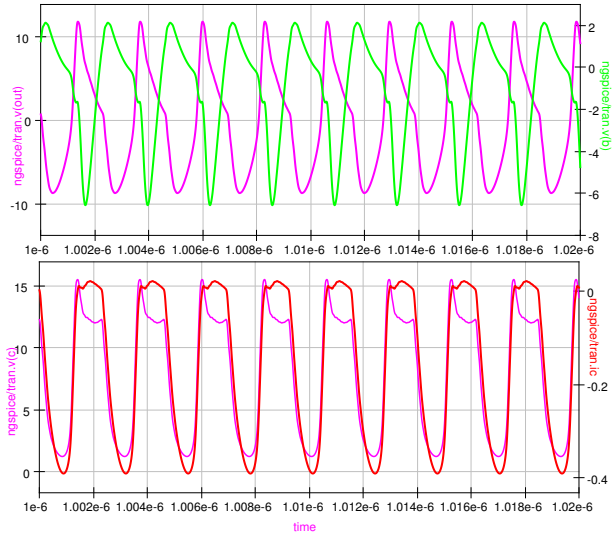

$$P_{out} = 0.82 \text{ W}, \text{ PAE} = 65 \%$$

$$P_{dc} = 1.2 \text{ W}, P_{in} = 29 \text{ mW}, G = 14 \text{ dB}$$

Comparison ABC: Harmonic Content

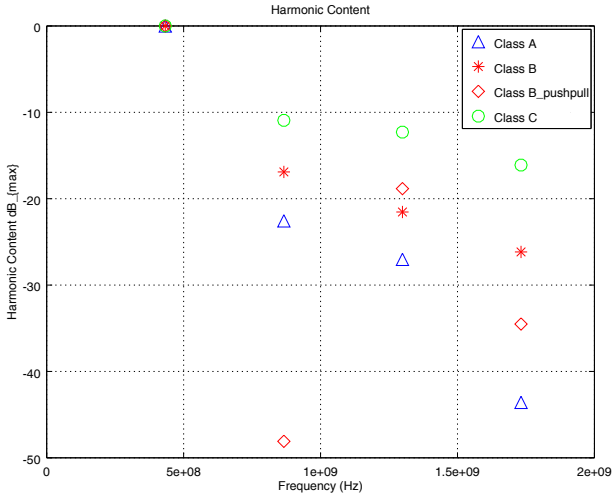

Comparison of harmonic content in output signal. Simulation engine: Xyce (Serial) via QUCS



Switching Amplifiers

- 14 Power Amplifiers
 - Classes A,B,C
 - **Switching Amplifiers**
- 15 Mixers for Frequency Translation

Higher Classes: Switching Amplifiers

	A	AB	B	C	D	E	F
Principle	Analogue				Digital		
# Transistors	1	2	2	1 (2)	2	1	1
η_{theory}	50 %	50-78 %	78.5 %	100 %			
P_{out}	☯			☹	😊		
Linearity	😊		☯	☹			
Cooling	☹			☯	😊		

Switching: Signal Form at Input

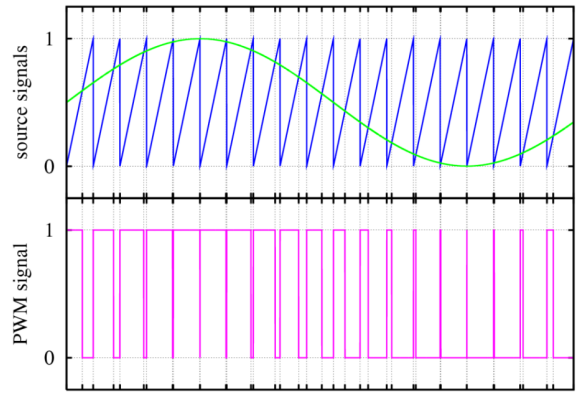

Pulse-width-modulation as input for switching amplifier

Class D CMCD

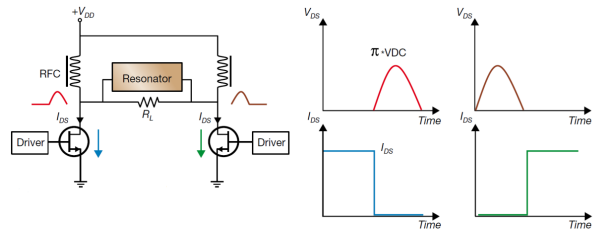

Current Mode Class D Switching Amplifier

References

RF Basics

System
Overview

Fields &
Waves

Transmission
Lines

Practical TL

2-Port and
S-Parameters

Matching

Antennas

Passives

Transistors

Linear
Amplifier

Noise

Mixers for Frequency Translation

- 13 Non-Linearities and Power Amplifiers
- 14 Power Amplifiers
- 15 Mixers for Frequency Translation**
- 16 Radar Introduction
- 17 Oscillators

- An initially non-linear device
- Changing the carrier frequency of the wanted signal
- Integral part of virtually every communication system
- Built of very simple components with very complex requirements

This Chapter Will Enable You To

- Understand and describe mixer operation
- Select different mixer types according to your application
- Characterize mixer in oinear and non-linear performance
- Design a basic mixer

Mixer in the System

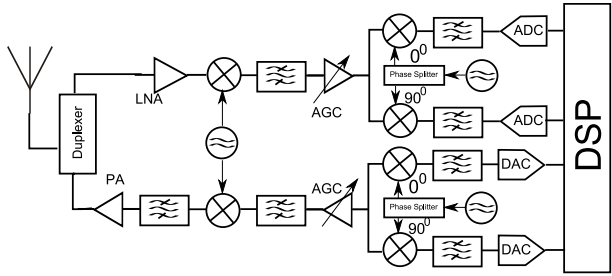

- (Usually) Mixer at two locations (per branch) in the system
 - Up- and Down-converter to translate from/to an intermediate frequency to/from a carrier frequency
 - As basic building block of a modulator

- RF Basics
- System Overview
- Fields & Waves
- Transmission Lines
- Practical TL
- 2-Port and S-Parameters
- Matching
- Antennas
- Passives
- Transistors
- Linear Amplifier
- Noise
- Linearities

15 Mixers for Frequency Translation

- Model
- Structure
- Examples
- Harmonic Balance
- More Diode Mixers
- FET and BJT Mixers
- Noise in Mixers

16 Radar Introduction

The Ideal Mixer and How We Use It

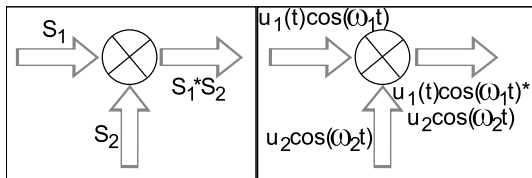

- Simply speaking the mixer is a multiplier
- More specifically: In RF mainly used to multiply
 - a $s_1 = u_1(t) \cos(\omega_1 t)$ with quiet slowly varying $u_1(t)$
 - with a so called local oscillator $u_2 \cos(\omega_2 t)$. u_2 mostly fixed
- Result is (let's fix also u_1 for a while)

$$u_{out}(t) = u_1 \cos(\omega_1 t) \cdot u_2 \cos(\omega_2 t) = \frac{u_1 u_2}{2} [\cos([\omega_1 + \omega_2]t) + \cos([\omega_1 - \omega_2]t)]$$
- Sum and difference frequency arise \rightarrow frequency conversion

Application of Frequency Conversion

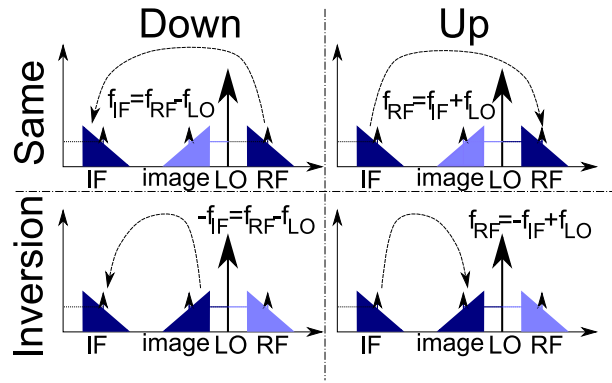

- Four fundamental frequency conversion modes
- Up- and Down-Conversion without frequency inversion and with frequency inversion
- To be selected according to the application used

Model of the Switch

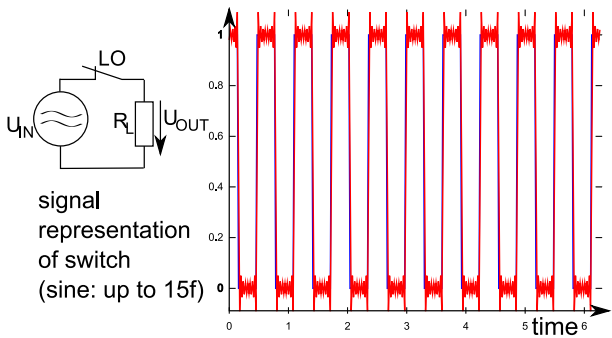

- This (somewhat specialized) multiplication can be accomplished by a switch
- Switching is like multiplication with a rectangle-signal
- Rectangle consists of odd-frequency sine or cosine like
$$r(t) = 1 + \cos(\omega t) - \frac{1}{3} \cos(3\omega t) + \frac{1}{5} \cos(5\omega t) - \dots$$
- (Note Gibb's phenomenon in the figure above)

Switch Mixer: The Multiplication

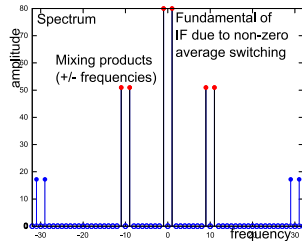
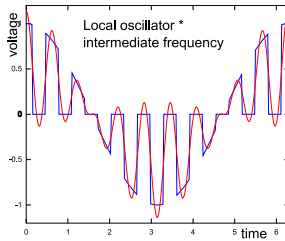
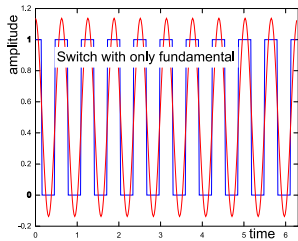

- Fundamental of switch does frequency conversion (harmonics can also be used → sub-harmonic mixing)
- Ideal switch-mixer does not explain any non-idealities

Getting Real: What Kind of Switch?

Now, how to switch at rates of a multi-billion times a second?

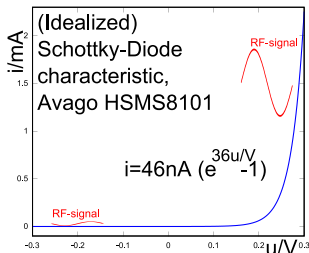

- Schottky diode driven by (large) LO voltage
- For reference. Diode characteristic is like $i(u) = I_0 (e^{\frac{q}{nkT}u} - 1)$
- LO-voltage switches diode almost like switch (open and shut) for smaller RF/IF voltage
 - High (momentary) LO-voltage: Low differential resistance
 - Low (momentary) LO-voltage: High differential resistance

- RF Basics
- System Overview
- Fields & Waves
- Transmission Lines
- Practical TL
- 2-Port and S-Parameters
- Matching
- Antennas
- Passives
- Transistors
- Linear Amplifier
- Noise

15 Mixers for Frequency Translation

- Model
- **Structure**
- Examples
- Harmonic Balance
- More Diode Mixers
- FET and BJT Mixers
- Noise in Mixers

16 Radar Introduction

(Most) Simple Mixer Structure

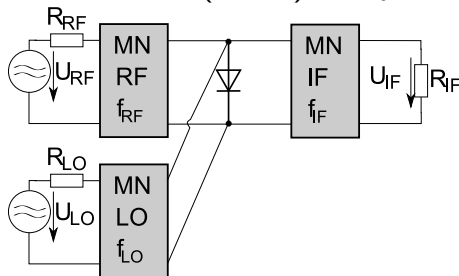

(Most) simple mixer: Here naming as down-converter

- One diode driven by LO-signal, RF-signal applied
- Matching networks: filtering to couple wanted signals
- Challenge: Present optimum impedances to diode at all frequencies
- Combine and separate the signals (as ALL signals are essentially at ONE port)
- Here important: $u_{LO,0} \gg u_{RF,IF,0}$, otherwise RF/IF would drive the diode \rightarrow non-linear conversion.

Spectrum of a Mixer

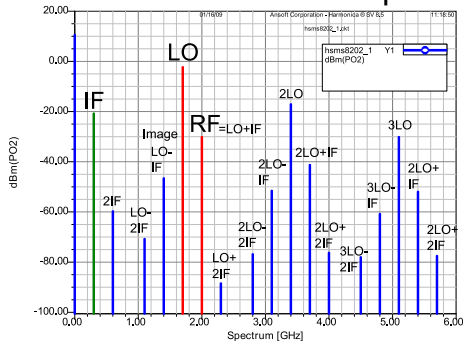

Spectrum (part of it) of a mixer (will be revisited later)

- Spectral components arise at $\pm n\omega_{LO} \pm m\omega_{IN}$ IN may be IF or RF, but essentially does not matter.
 - n, m are non-negative integer values
 - $|n| + |m|$ is order of harmonic
- Power at spectral line determined by input powers of LO and input signal and of exact non linear and linear (filter) characteristic of the system

Some Parameters of the Diode-Mixer

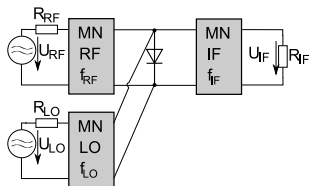

- (Large signal) input impedance (match) of the diode at LO-frequency
- (Small signal) input impedance (match) of the pumped diode at RF-frequency (input)
- (Small signal) output impedance (match) of the pumped diode at IF-frequency (output)
- Match of the diode at other, unwanted frequencies (harmonics, image)
- Isolation between ports, especially LO-isolation

If all these parameters are known, mixer-design is matching only

Macroscopic Parameters of Mixers

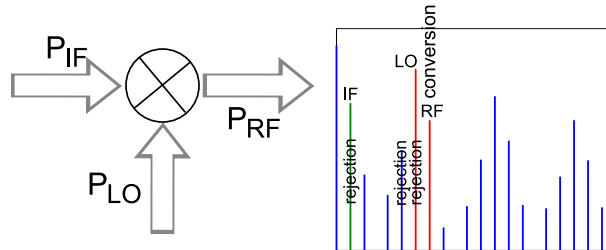

- Parameters with LO one-tone input (given for IF=in and RF=out)
 - Conversion Gain (loss) $G = \frac{P_{out,RF}}{P_{in,IF}}$, ($L = 1/G$)
 - Also defined 1 dB compression of conversion gain
 - Various rejection and isolation measures examples:
 - Image rejection $R_{out,IM} = \frac{P_{out,RF}}{P_{out,IM}}$
 - LO-Isolation $I_{out,LO} = \frac{P_{out,LO}}{P_{in,LO}}$

Non-Linear Performance in a System

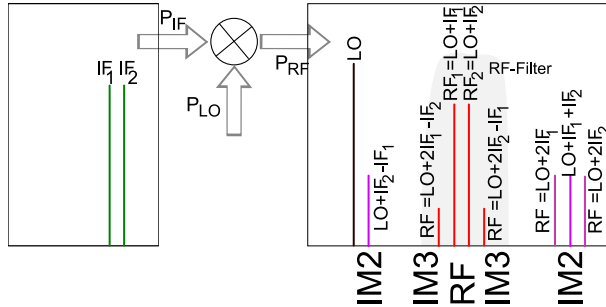

Mixer performance/ spectrum with two tones at input

- Intermodulation products of 2nd and 3rd (theoretically also more) order arise
- If IF (RF) selected correctly (i.e. $f_{min,IF} > f_{max,IF} - f_{min,IF}$) most important, again, is IM3. (IM2 can be filtered more easily)

Intercept, Compression, and Noise

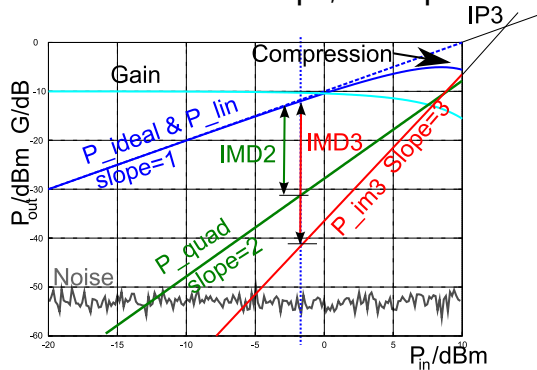

Compression, Intercept-Point, and Intermodulation products/ distances

- Noise-figure (defined as decrease of signal-to-noise-ratio at out compared to SNR at in) for diode-mixers is a little bit (about 0.5 dB) higher than the conversion loss, later exact calculations will follow
- Compression point (for single diode mixers) is about 6 dB below the IP3 (intercept point of third order)

Schottky Diode

Commonly (but no way exclusively) used non-linear element for mixers: **The Schottky-Diode**

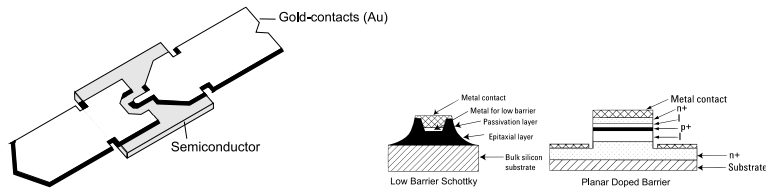

(a) Beam-lead technology for high frequency (it's all about packaging), (b) Epitaxial layers

- Metal-Semiconductor Junction
 - First Semiconductor-Component, First electronic component in RF-techniques
 - Experiment: Ferdinand Braun (1874), Theory: Walter Schottky (1938)

Physics of the Schottky-Diode

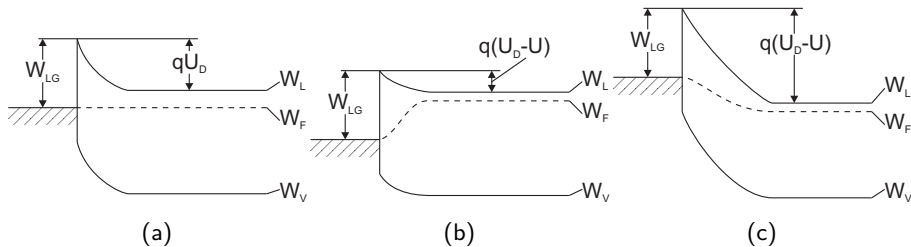

(a) $U = 0$

(b) $U > 0$ Forward Bias: Current flow, electrons Semiconductor \rightarrow Metal

(c) $U < 0$ Reverse-Bias, no current flow

- No Minority-carriers (only majority carriers) \rightarrow no diffusion capacitance \rightarrow no charge delay

Schottky-Diode Equivalent Circuit

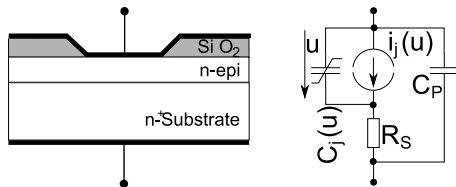

Epitaxy and simple equivalent circuit for Schottky Diode

- $I(U) = I_0 \left(e^{\frac{q}{n k T} U} - 1 \right)$, $n = 1 \dots 2$ ideality factor, $\alpha = \frac{q}{n k T} \approx 36/V$
- Small signal resistance $\frac{1}{r} = \frac{dI(U)}{dU} = \alpha I_0 (e^{\alpha U} - 1 + 1) = \alpha(I + I_0)$
- Non-linear junction capacitance $C_j(U) = \frac{C_{j0}}{\sqrt{1 - \frac{U}{\Phi}}}$
- Max-frequency is determined by rate possible to reverse charge the junction capacitance via the series resistor $f_{max} = \frac{1}{2\pi C_{j0} R_S} = \dots 1000 \text{ GHz}$

Enhanced Spice Diode Model I

Model as used in common design SW

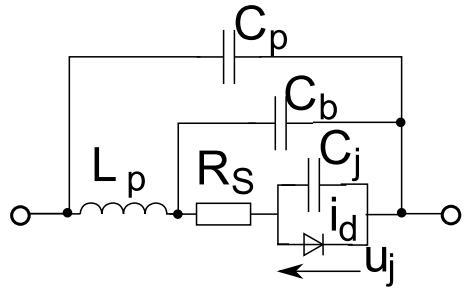

Enhanced Spice Diode Model II

Parameters (e.g. for Avago HSMS-8202 Diode)

Saturation Current	I_S, I_0	46 nA
Barrier Height	$E_G \approx \Phi$	0.69 V
Series Resistance	R_S	0.6 Ω
Zero Bias junction Cap.	C_{j0}	0.18 fF
Breakdown voltage	B_V	7.3 V
Junction Grading coef.	M	0.5
Current at B_V	I_{BV}	10 μ A
Forw. Bias depl. coef	FC, γ	0.5
Ideality factor	n	1.09
transit Time	TT	0

Derived parameters

Max.-frequency	$f_c = 1/(2\pi R_S C_{j0})$	147 GHz
Selfbias junc. resistance	$r = \alpha/(I + I_0)$	
	1 mA	263 Ω
	2.5 mA	142 Ω

Comments on Noise of the Schottky-Diode

- Shot-noise $\overline{i_N^2} \approx 2kTB/r$

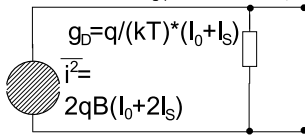

- Small signal resistance r is noise-less (even if the formula above suggests something different)
- Noise-contribution of the diode itself very small
- Signal-to-Noise-ratio only worsened by attenuation of the signal itself (and thermal noise floor stays constant)

(Ideal) Switch-mixer as Downconverter

Just for illustration and understanding. The time-domain-waveforms of an ideal mixer with switch ($\omega_{LO} = 10, \omega_{RF} = 11$)

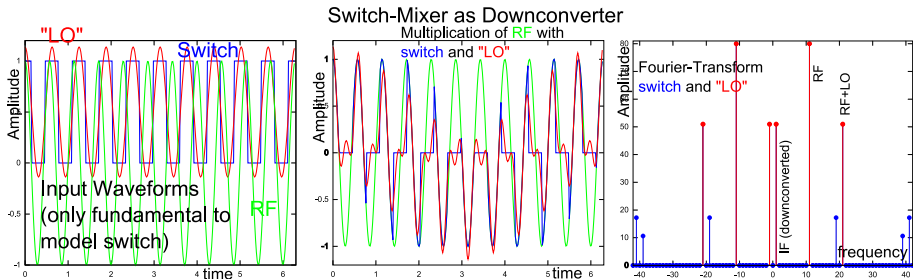

Note that there really! is the IF at frequency $\omega_{IF} = 1$

- RF Basics
- System Overview
- Fields & Waves
- Transmission Lines
- Practical TL
- 2-Port and S-Parameters
- Matching
- Antennas
- Passives
- Transistors
- Linear Amplifier
- Noise
- Linearities

15 Mixers for Frequency Translation

- Model
- Structure
- **Examples**
- Harmonic Balance
- More Diode Mixers
- FET and BJT Mixers
- Noise in Mixers

16 Radar Introduction

Example of a (Very Simple!) Single-Diode-Mixer

Mixer Schematic set up for mixing 2 GHz to 300 MHz. Used Schottky Diode is the Avago HSMS8202

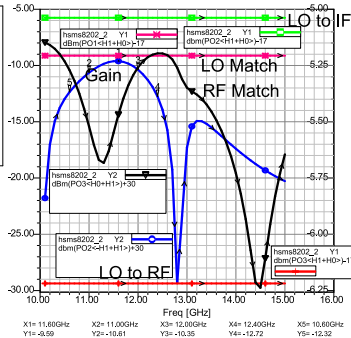
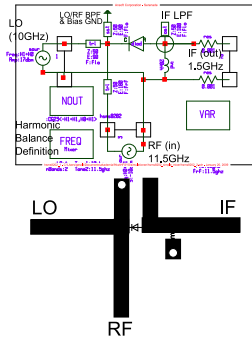

- Bandpass-filter at LO and RF-port
- Low-pass-filter (just couple Cap to ground) at IF port

Mixer in Time-Domain

01/20/09

Ansoft Corporation - Harmonica © SV 8.5
la(hsms8202),la(hsms8202),
hsms8202_1.ckt

17:14:59

01/20/09

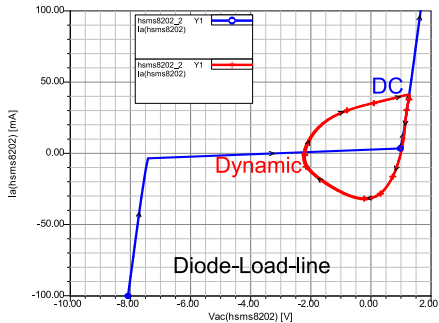

01/20/09

Ansoft Corporation - Harmonica © SV 8.5
hsms8202_1.ckt

17:16:41

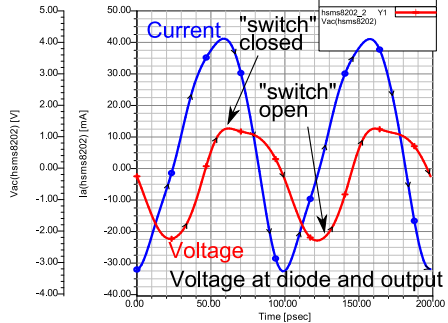

Mixer Spectrum

01/20/09

Ansoft Corporation - Harmonica © SV 8.5

17:17:06

01/20/09

Ansoft Corporation - Harmonica © SV 8.5

17:32:09

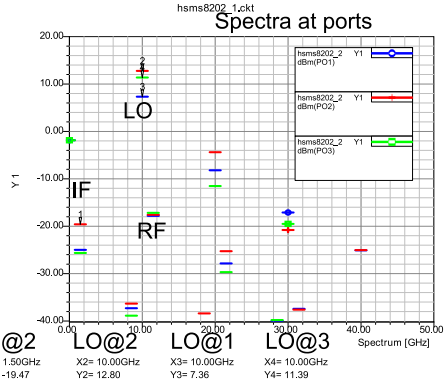
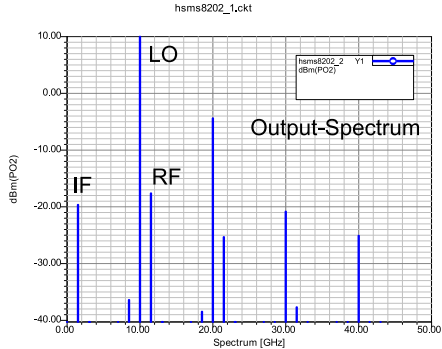

- Conversion gain (as calculated from available RF-power [-10 dBm]) is -10.56 dB
- LO-isolation to RF-port is very bad, LO available is 17 dBm and at port 3 it is 12.24 dBm, so virtually no isolation (5 dBm). That is the problem of only one diode
- Similarly applies to some other isolation measures

Powers at the Single-Diode Mixer

01/20/09

Ansoft Corporation - Harmonica © SV 8.5

17:43:07/20/09

Ansoft Corporation - Harmonica © SV 8.5

18:13:33

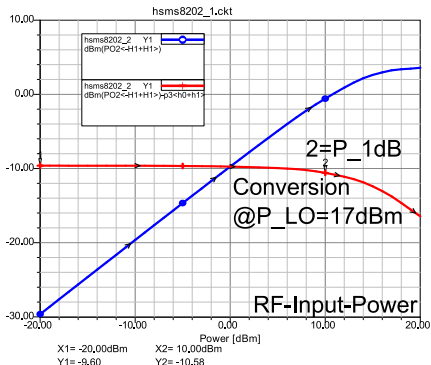
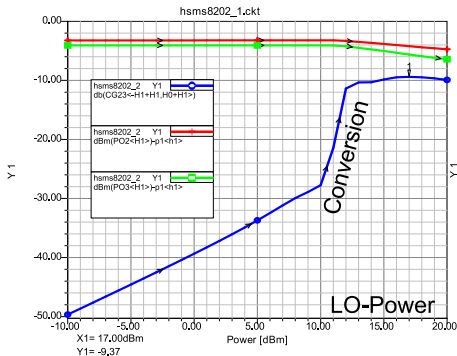

Output powers/ signals as functions of varied LO-Power and RF-Input power.

Harmonic Balance

- RF Basics
- System Overview
- Fields & Waves
- Transmission Lines
- Practical TL
- 2-Port and S-Parameters
- Matching
- Antennas
- Passives
- Transistors
- Linear Amplifier
- Noise

15 Mixers for Frequency Translation

- Model
- Structure
- Examples
- **Harmonic Balance**
- More Diode Mixers
- FET and BJT Mixers
- Noise in Mixers

16 Radar Introduction

Simulation Techniques

- One could use full time-domain transient solvers such as SPICE
 - + Conceptionally simple
 - + Already many solvers available (e.g. SPICE)
 - High-frequency and long component settling time = long time to simulate = long computation time
 - Transmission/ delay components difficult to handle in time domain (it just may take multiple periods to get the refecion back = long simulation and computation times)
- Different concept:
Take best from both worlds (frequency domain = RF, and time domain = SPICE)
- Additional advantage:
Often (as in amplifiers, mixers, (frequency) multipliers) source frequencies are known (fundamental difference to oscillator!)

Harmonic Balance: Idea I

Most common and widely used simulation technique for analysis of circuits with non-linear components in microwave engineering

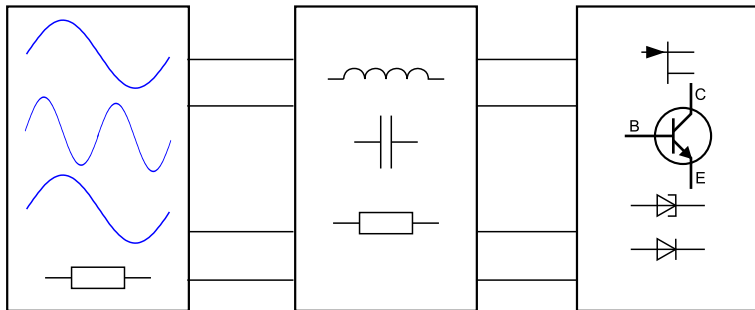

Harmonic Balance: Idea II

Most common and widely used simulation technique for analysis of circuits with non-linear components in microwave engineering

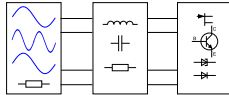

Simple idea

- ① Sources are only at discrete and known frequencies (tones)
- ② Through non-linear processes only the discrete harmonics of the above tones arise
- ③ Total circuit will be split in three parts:
 - ① Sources and loads
 - ② Linear subcircuit (to be dealt with with normal linear simulation techniques)
 - ③ Non-linear subcircuit, possibly differential equations (time-delays). To be worked out in time-domain
- ④ Recombine all required currents and voltage at interface
- ⑤ Do this iteratively until desired accuracy (convergence) is reached

Algorithm I

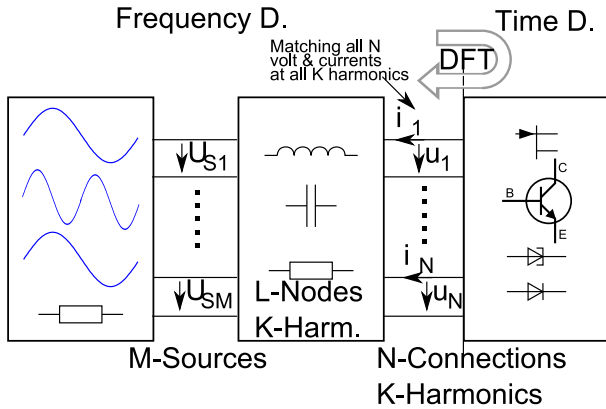

- Create nodal analysis-(transadmittance) matrix $(\bar{\bar{Y}})$ for all nodes in the linear subnetwork

Algorithm II

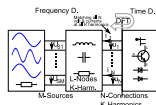

- Currents at the connections to non-linear NW are

$$\vec{I}^N = \overline{\overline{Y}}_S^{N \times M} \vec{V}_S^N + \overline{\overline{Y}}^{N \times N} \vec{V}^N = \vec{I}_S^N + \overline{\overline{Y}}^{N \times N} \vec{V}^N$$

Note that superscripts denote the sizes and that these equations must be set up for every interesting frequency (harmonic) (K), or rather the K harmonics will be integrated in the equation above.

- Since we are only looking for harmonics, all currents and voltages are of the form

$$u(t) = \sum_{k=-K}^K U_k e^{jk\omega t}$$

- In the non-linear sub-NW (we work in time domain) we find

$$i(t) = \Phi \left(u(t), \frac{du(t)}{dt}, \dots, \frac{d^n u(t)}{dt^n}, u(t - \tau) \right)$$

$$q(t) = \Psi \left(u(t), \frac{du(t)}{dt}, \dots, \frac{d^n u(t)}{dt^n}, u(t - \tau) \right)$$

considering mainly solid-state devices, that have non-linear capacitances (q), but not non-linear inductors, therefore we can neglect those

- Transform this back via DFT into the frequency domain
- **Harmonic Balance Equation:** Match current and voltages at all connections

$$\text{yields } \vec{E} = \vec{Y}\vec{U} + \vec{I}_S + \vec{I}_G + j\vec{\Omega}\vec{Q} \doteq 0$$

Algorithm IV

- The job is done, when this equation is fulfilled (i.e. error vector $\vec{E} \cdot \vec{E}^T$ is minimized (iterative algorithm))
 - Start with a some assumption (e.g. the DC solution obtained from transient analysis)
 - Set-up the equation and then use some minimization algorithm (Newton-Raphson-Algorithm) to walk to the solution

This seems concetionally simple, but is too hard to do by hand. For the computer you must consider:

- Large number of Harmonics (possibly with multitone excitation) and large networks
- ⇒ Large system of equations, high memory requiremens and long time for calculation
- ⇒ Slow (or bad) convergence, especially unreliable when (as in a mixer) one component (LO) is much larger than others (RF)

More Diode Mixers

15 Mixers for Frequency Translation

- Model
- Structure
- Examples
- Harmonic Balance
- **More Diode Mixers**
- FET and BJT Mixers
- Noise in Mixers

16 Radar Introduction

Balanced and Other Diode Mixers

Are we satisfied with the Single-Diode-mixer?



It's cheap and simple



Isolation between ports is bad (all signals everywhere)



Dynamic range is bad (RF-efficiency bad, because matching bad)



LO-efficiency bad

Balanced Mixers

Generic form of a balanced mixer, coupler couples equal power but different phase.

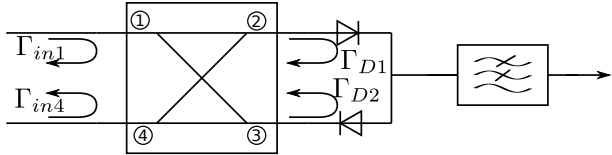

Balanced Mixers: Signal Flow Graph

Signal flow Graph for the generic balanced mixer (idealized)

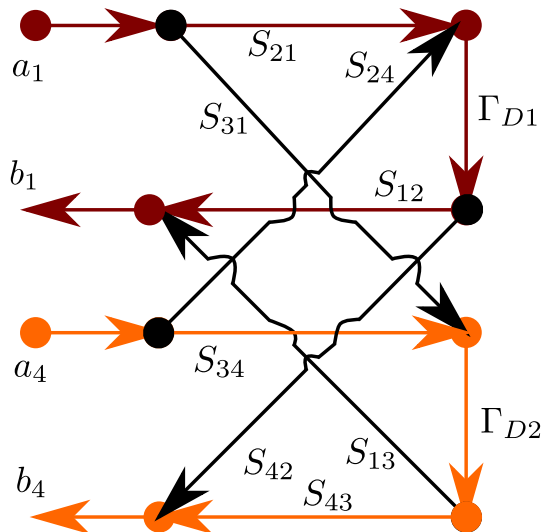

Balanced Mixers: Solution

Solution of the signal Flow Graph (equal Diodes) $\Gamma_{D2} = \Gamma_{D1} = \Gamma$ and equal power $|S_{ij}| = S$ all equal and symmetric $S_{ij}/|S_{ij}| = S_{ji}/|S_{ji}| = p_{ij} \quad |p| = 1$

$$\Gamma_{in1} = \frac{b_1}{a_1} = S_{21}S_{12}\Gamma_{D1} + S_{31}S_{13}\Gamma_{D2} = S^2\Gamma(p_{21}^2 + p_{31}^2)$$

$$T_{41} = \frac{b_4}{a_1} = S_{21}S_{42}\Gamma_{D1} + S_{31}S_{43}\Gamma_{D2} = S^2\Gamma(p_{21}p_{42} + p_{31}p_{43})$$

$$\Gamma_{in4} = \frac{b_4}{a_4} = S_{24}S_{42}\Gamma_{D1} + S_{34}S_{43}\Gamma_{D2} = S^2\Gamma(p_{24}^2 + p_{43}^2)$$

$$T_{14} = \frac{b_1}{a_4} = S_{24}S_{12}\Gamma_{D1} + S_{34}S_{13}\Gamma_{D2} = S^2\Gamma(p_{24}p_{12} + p_{34}p_{13})$$

Balanced Mixers with Hybrid Coupler

Perfect match of LO and RF

Straight path is reference: $p_{21} = p_{12} = p_{34} = p_{43} = 1$, diagonal path is 90° phase shift: $p_{31} = p_{13} = p_{24} = p_{42} = j$ and no power lost $S = 1/\sqrt{2}$

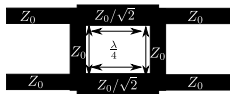

$$\Gamma_{in1} = \frac{\Gamma}{2}(2 - 2) = 0$$

$$T_{41} = \frac{b_4}{a_1} = j\Gamma$$

$$\Gamma_{in4} = 0$$

$$T_{14} = j\Gamma$$

Balanced Mixers with Rat Race Coupler

Perfect isolation of LO and RF

Short paths are reference: $p_{21} = p_{12} = p_{31} = p_{13} = p_{34} = p_{43} = 1$, long path is 180° (relative)

phase shift: $p_{24} = p_{42} = -1$ and no power lost $S = 1/\sqrt{2}$

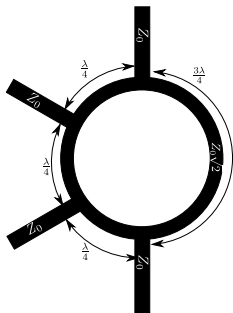

$$\Gamma_{in1} = \Gamma$$

$$\Gamma_{in4} = \Gamma$$

$$T_{41} = 0$$

$$T_{14} = 0$$

Hybrid-Coupler Balanced Mixer

Balanced Diode Mixer with Quadrature Coupler

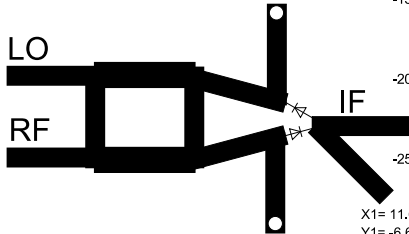
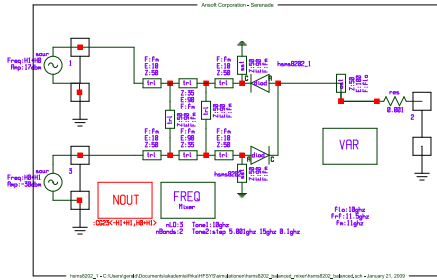

X1= 11.60GHz
Y1= -6.64

X2= 11.00GHz
Y2= -5.84

X3= 12.00GHz
Y3= -7.24

X4= 12.90GHz
Y4= -9.49

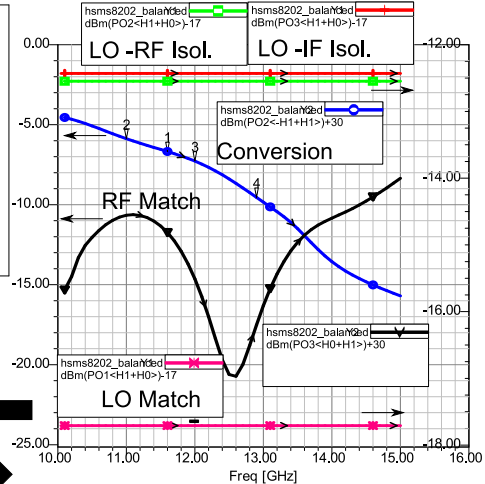

Rat-Race Coupler Balanced Mixer

Balanced Diode Mixer with Rat-race Coupler

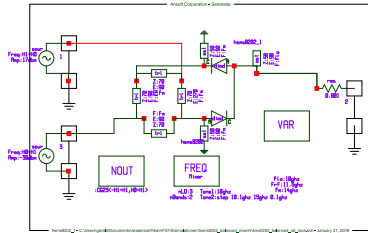

IF

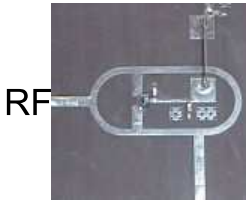

LO

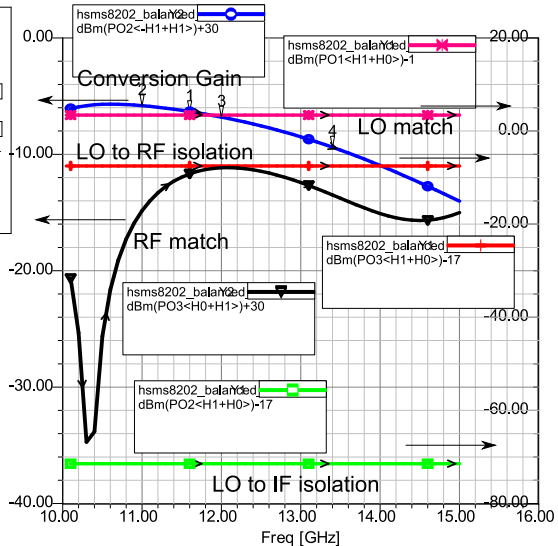

X1= 11.60GHz

X2= 11.00GHz

X3= 12.00GHz

X4= 13.40GHz

Y1= -6.33

Y2= -5.82

Y3= -6.80

Y4= -9.39

Image Reject Mixer

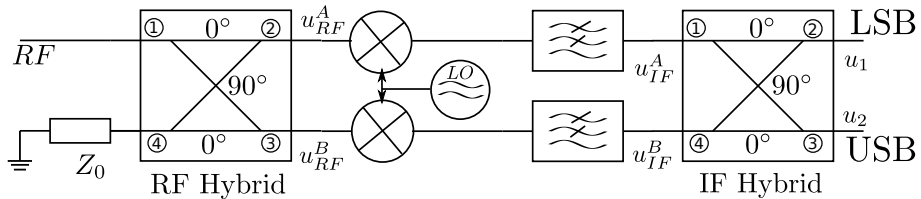

- Separates the lower and upper side band

Image Reject Mixer: Theory I

$$u_{RF}(t) = \hat{u}_u \cos(\omega_{LO} + \omega_{IF})t + \hat{u}_l \cos(\omega_{LO} - \omega_{IF})t$$

$$u_{RF}^A(t) = \frac{1}{\sqrt{2}} [\hat{u}_u \cos(\omega_{LO} + \omega_{IF})t + \hat{u}_l \cos(\omega_{LO} - \omega_{IF})t]$$

$$u_{RF}^B(t) = \frac{1}{\sqrt{2}} [\hat{u}_u \cos(\omega_{LO}t + \omega_{IF}t - 90^\circ) + \hat{u}_l \cos(\omega_{LO}t - \omega_{IF}t - 90^\circ)]$$

$$u_{IF}^A(t) = \frac{K}{2\sqrt{2}} [\hat{u}_u \cos(\omega_{IF}t) + \hat{u}_l \cos(\omega_{IF}t)] = \frac{K}{2\sqrt{2}} (\hat{u}_u + \hat{u}_l) \cos(\omega_{IF}t)$$

$$u_{IF}^B(t) = \frac{K}{2\sqrt{2}} [\hat{u}_u \cos(\omega_{IF}t - 90^\circ) + \hat{u}_l \cos(-\omega_{IF}t - 90^\circ)]$$

$$= \frac{K}{2\sqrt{2}} [\hat{u}_u \sin(\omega_{IF}t) - \hat{u}_l \sin(\omega_{IF}t)]$$

$$= \frac{K}{2\sqrt{2}} (\hat{u}_u - \hat{u}_l) \sin(\omega_{IF}t)$$

Image Reject Mixer: Theory II

So after the second coupler there is

$$\begin{aligned}u_1(t) &= \frac{K}{2\sqrt{2}} [(\hat{u}_u - \hat{u}_l) \sin(\omega_{IF}t - 90^\circ) + (\hat{u}_u + \hat{u}_l) \cos(\omega_{IF}t)] \\ &= \frac{K}{\sqrt{2}} \hat{u}_l \cos(\omega_{IF}t) \\ u_2(t) &= \frac{K}{2\sqrt{2}} [(\hat{u}_u - \hat{u}_l) \sin(\omega_{IF}t) + (\hat{u}_u + \hat{u}_l) \cos(\omega_{IF}t - 90^\circ)] \\ &= \frac{K}{\sqrt{2}} \hat{u}_u \sin(\omega_{IF}t)\end{aligned}$$

This shows that LSB and USB are at different ports

Low Frequency Hybrid

For low (IF) frequencies a narrow band hybrid coupler can be build from lumped LC-Element:

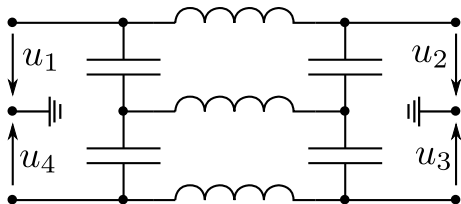

(a)

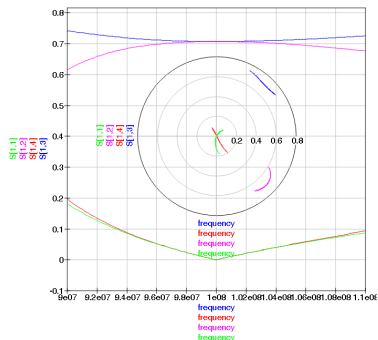

(b)

Lumped Element hybrid (a) and result (b) for 100 MHz

Design equation: $L = \frac{Z_0}{2\pi f_0}$ $C = \frac{1}{Z_0 2\pi f_0}$

Even More Diodes

Double balanced Mixer with four diodes

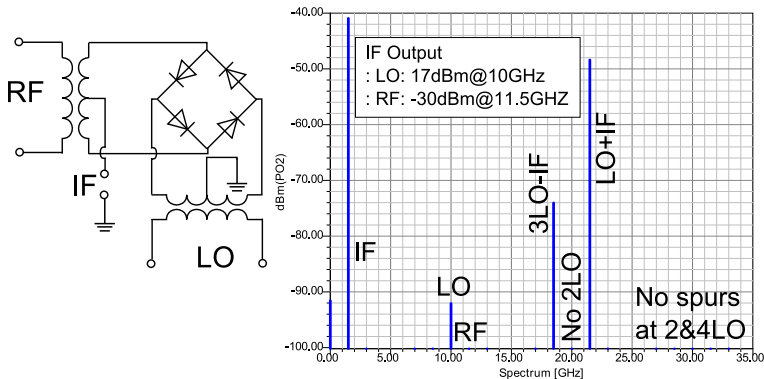

- Reverse polarity switch (always two diodes are open, two are short in rhythm of LO)
- Prevents DC and even order harmonics of LO and RF
- Shorted diodes effectively isolate RF and LO (and vice versa)
- Restricted by transformers. other than that. broadband

Comparison of Diode-Mixers

Data after [1]

	Single	Balanced	Doub. Bal.
Conversion Gain			
Spurious Perf.			
Dynamic Range			
Isolation			
Pump Power			
Complexity			
Bandwidth			

FET and BJT Mixers

15 Mixers for Frequency Translation

- Model
- Structure
- Examples
- Harmonic Balance
- More Diode Mixers
- **FET and BJT Mixers**
- Noise in Mixers

16 Radar Introduction

Gilbert-Cell Mixers

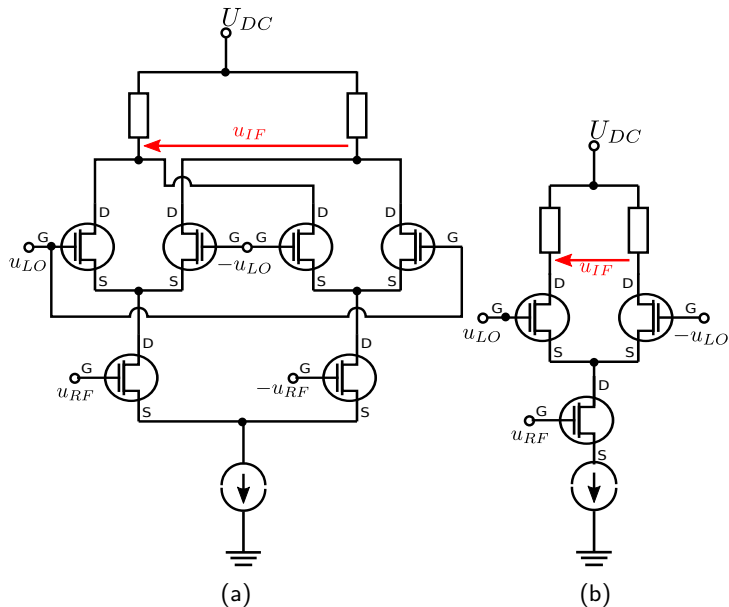

Gilbert Cell (Double Balanced Mixer) (a), single balanced mixer (b)

Gilbert-Cell Mixers: Function

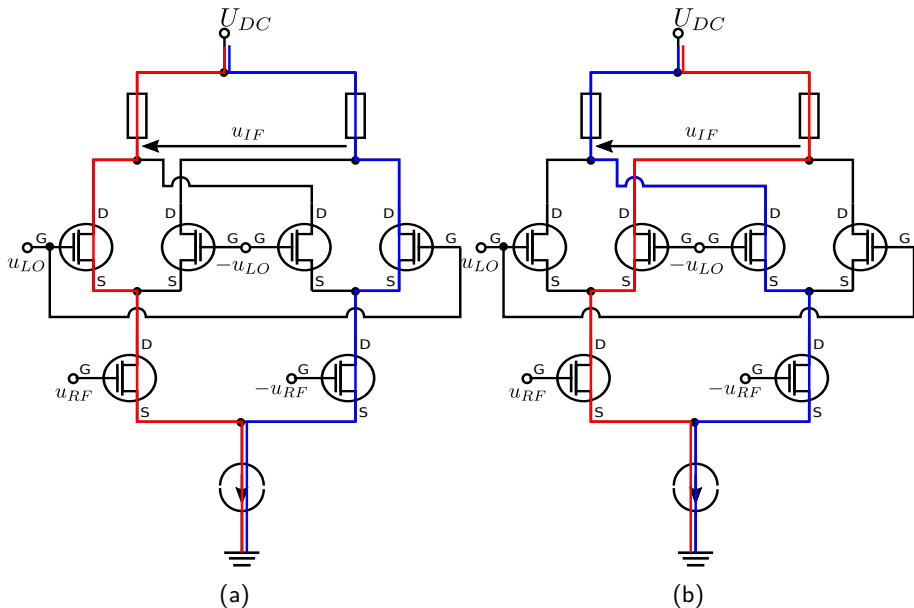

Positive half (a) and negative half (b) switching polarity of lower differential amplifier

Gilbert-Cell Mixers: Simulation

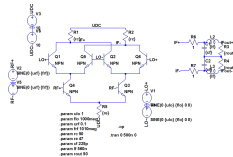

(a)

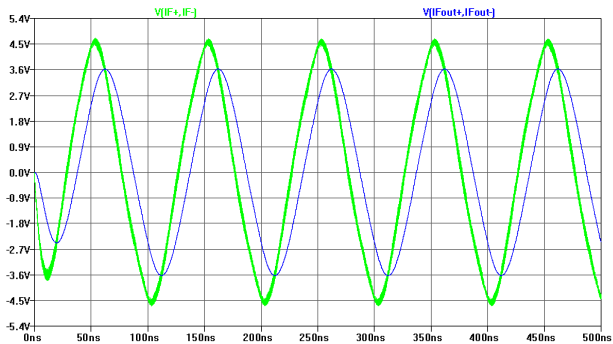

(b)

Simulation of a Gilbert Cell mixer.

Gilbert-Cell Mixers: Advantages



Bipolar or FET-technology possible



Integration (also with CMOS) possible



Good port isolation



Mixing with Gain



Balanced signal required



Complex design: limited in frequency range (only few GHz)



Poor noise (not demonstrated here)

- RF Basics
- System Overview
- Fields & Waves
- Transmission Lines
- Practical TL
- 2-Port and S-Parameters
- Matching
- Antennas
- Passives
- Transistors
- Linear Amplifier
- Noise
- Linearities

15 Mixers for Frequency Translation

- Model
- Structure
- Examples
- Harmonic Balance
- More Diode Mixers
- FET and BJT Mixers
- **Noise in Mixers**

16 Radar Introduction

Noise in Mixers

Distinguish between Single Side Band (SSB) and Double Side Band DSB mixer noise.

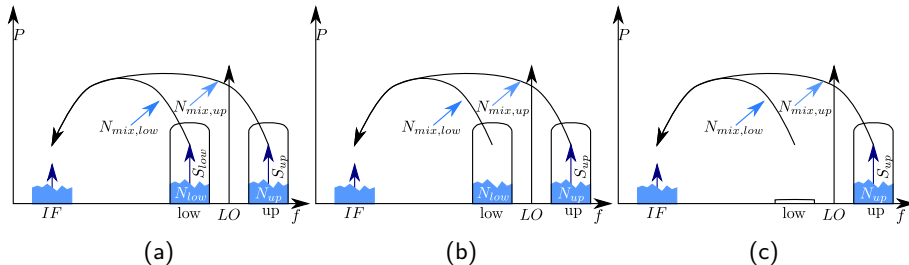

Double-Side Band (a), Single Side Band (SSB) (b) and SSB with filtered image.

Noise in Mixers: DSB I

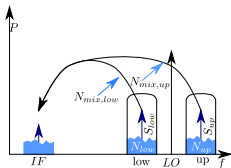

Calculation for situation shown (adapt accordingly for different situations)

$$S_{IF} = S_{up}G_{up} + S_{low}G_{low}$$

$$N_{IF} = N_{up}G_{up} + N_{low}G_{low} + N_{mix,up}G_{up} + N_{mix,low}G_{low}$$

with mixer noise contribution projected at the input and G_{up} , G_{low} conversions in different bands.

Noise in Mixers: DSB II

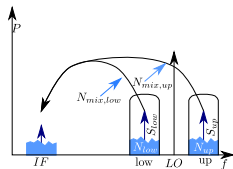

For simplified relations:

$$N_{in} = N_{up} = N_{low}, \quad N_{mix} = N_{mix,up} = N_{mix,low}$$

$$G = G_{up} = G_{low}, \quad S = S_{up} = S_{low},$$

$$S_{IF} = 2SG, \quad N_{IF} = 2N_{in}G + 2N_{mix}G$$

$$\frac{S_{IF}}{N_{IF}} = \frac{2SG}{2N_{in}G + 2N_{mix}G} = \frac{S}{N_{in}} \frac{1}{1 + \frac{N_{mix}}{N_{in}}}$$

$$F_{DSB} = 1 + \frac{N_{mix}}{N_{in}}$$

Noise in Mixers: SSB

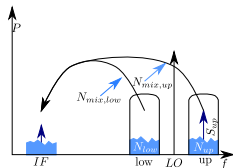

Calculation for situation shown (adapt accordingly for different situations)

$$S_{IF} = S_{up} G_{up}$$

$$N_{IF} = N_{up} G_{up} + N_{low} G_{low} + N_{mix,up} G_{up} + N_{mix,low} G_{low}$$

as before, simplification as above yields

$$S_{IF} = SG, \quad N_{IF} = 2N_{in}G + 2N_{mix}G$$

$$\frac{S_{IF}}{N_{IF}} = \frac{SG}{2N_{in}G + 2N_{mix}G} = \frac{S}{N_{in}} \frac{1}{2 + \frac{2N_{mix}}{N_{in}}}$$

Noise in Mixers: SSB Filtered

It's unfair to blame the mixer for an unwanted noise in the sideband? OK....

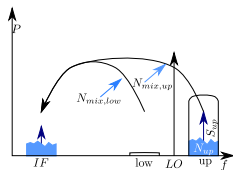

Calculation for situation shown (adapt accordingly for different situations)

$$S_{IF} = S_{up} G_{up} \quad N_{IF} = N_{up} G_{up} + N_{mix,up} G_{up} + N_{mix,low} G_{low}$$

as before, simplification as above yields

$$S_{IF} = SG, \quad N_{IF} = N_{in} G + 2N_{mix} G$$

$$\frac{S_{IF}}{N_{IF}} = \frac{SG}{N_{in} G + 2N_{mix} G} = \frac{S}{N_{in}} \frac{1}{1 + \frac{2N_{mix}}{N_{in}}}$$

References

RF Basics

System
Overview

Fields &
Waves

Transmission
Lines

Practical TL

2-Port and
S-Parameters

Matching

Antennas

Passives

Transistors

Linear
Amplifier

Noise



G. D. Vendelin, A. M. Pavio und U. L. Rohde. *Microwave Circuit Design Using Linear and Nonlinear Techniques*. John Wiley and Sons, 1990.

Radar Introduction

14 Power Amplifiers

15 Mixers for Frequency Translation

16 Radar Introduction

17 Oscillators

What to Learn

- How does Radar work?
- What does a Radar System look like
- The radar equation
- Different kinds of radar
- Some specialties (Noise, matched filter)

For more information see [1, 2]

Trivia

- RF Basics
- System Overview
- Fields & Waves
- Transmission Lines
- Practical TL
- 2-Port and S-Parameters
- Matching
- Antennas
- Passives
- Transistors
- Linear Amplifier
- Noise
- Linearities

Radar= Radio Detection and Ranging, so it means that a target should be detected and ranged (i.e. its distance from measurement point shall be determined). Radar became "popular" during WWII to detect targets (mostly ships and aircrafts) of the enemy.

Types of Radar (Application side) I

- Flight Control Radar
 - Surveillance and flight control
 - weather radar
 - taxiing
 - detect possible danger (birds)
- Ships
 - Detect ships near coast and harbour, or ship-ship detection to avoid collision
 - Navigational Aid (vision in bad weather)
 - Search and Rescue
- Rail and car traffic
 - Contactless Measurement of speed, distance, acceleration
 - Sensor for autonomous driving
 - Find obstacles (parking aid), distance to wagons

Types of Radar (Application side) II

- Earth surveillance and discovery
 - Geo-sciences
 - Agriculture
 - Environmental protection
- Meteorology and aerospace
 - weather radar (find rain, storms)
 - measurements on earth, detection of vegetation
- Manufacturing processes
 - contactless measurement of position, speed, distance etc.
- Smart Buildings
 - Occupancy detection
 - Life detection (heart beat)

Types of Radar (Application side) III

- Approach detection and security measures
- And lots of military applications in a.m. disciplines

Examples can be found under

<http://www.radartutorial.eu/19.kartei/ka01.de.html>

Types of Radar: More Technical Side I

Surveillance Radar to search and observe a specified area for objects (e.g. some air volume for planes and rockets, some coast).

Target Tracking Radar is used to track a target (military or civilian), i.e. the radar signal is optimized (focused) to track the target, that previously has been found by the a.m.

Measurement Radar

Synthetic Aperture Radar (not covered here), where a large antenna area is generated by a moving radar system and later signal processing, used for precise imaging.

Types of radar: Purely Technical

Pulse (Doppler) Radar send out a modulated pulse and detects via measurement of delay of received pulse the distance to target and frequency shift its speed. This is the standard idea.

Continuous Wave (CW) Radar sends out a sinusoidal CW signal and detects if there is a shifted frequency in the received signal → there is some movement in the area

Frequency Modulated CW Radar (FMCW) sends out a chirped signal and can measure speed and distance from fourier-transform of received signal

How does Radar Work?

- Send out a signal (e.g. modulated pulse, chirp, CW-signal)
- Receive/ measure the echo
- calculated desired parameters (distance, angle of observance, speed)

Radar Principle and Terms

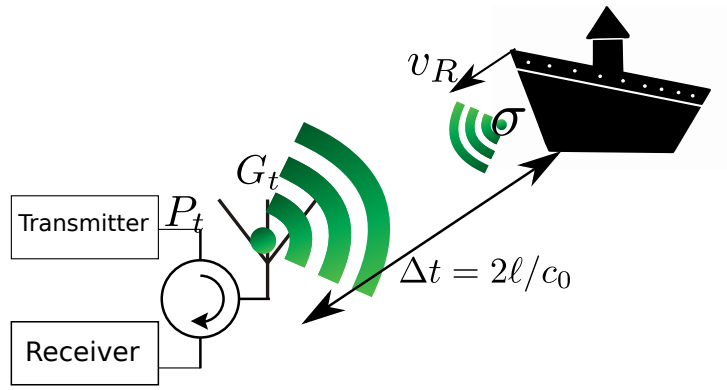

with

- Δt time difference between sending and receiving the pulse,
- σ the target's scattering cross section,
- v_R the radial (toward the radar system) speed of the target
- P_t transmitted power and G_t Gain of the transmitting antenna

Radar Equation

- A modulated (with f_0) impulse of power P_S and duration t_p and pulse repetition period T is sent.
- Pulse is attenuated on way to target by power density $\frac{P_t G_t}{\ell^2} = S_t$
- Reflected power is $\frac{\sigma}{4\pi}$ per radiant
- Receiving antenna can make $\frac{A_r}{4\pi\ell^2}$ out of the reflected power

Full equation is thus

$$\begin{aligned}
 P_r &= P_t G_t \frac{\sigma}{4\pi} \frac{A_r}{4\pi} \frac{1}{\ell^4} = P_t \frac{G_t \sigma A_r}{(4\pi)^2 \ell^4} \\
 &= P_t \frac{G_t \sigma G_r \lambda^2}{(4\pi)^3 \ell^4} \Rightarrow P_t \frac{G_t \sigma G_r \lambda^2}{(4\pi)^3 \ell^4} \frac{1}{L_t L_{atm}}
 \end{aligned}$$

Note the $1/\ell^4$ decay of signal strength, which greatly limits detection range, and the atmospheric and cable losses L_{atm} and L_t .

σ is the (virtual) reflection area of the target.

Definition $\sigma = \frac{4\pi\ell^2 S_r}{S_t}$ with S_r the reflected power density and thus $4\pi\ell^2 S_r$ the virtual total power reflected by the target, if it were uniformly distributed on a sphere with radius ℓ , S_t the incident power density and

It only seems to increase with ℓ^2 , but also S_t drops the same, so ℓ cancels out.

Radar Cross Section II

Simple geometries with $x \gg \lambda$,

Geometry	σ
metallic sphere	πr^2
rectangle (perp. to signal)	$\frac{4\pi b^2 h^2}{\lambda^2}$
rectangle (any other angle)	0
cylinder	$\frac{2\pi r h^2}{\lambda}$
bird	0.01 m ²
(wo)man	1 m ²
car	100 m ²
truck	200 m ²
ship (broadside)	up to 500 m ²
radar reflector	20000 m ²

Radar Cross Section III

According to

[http:](http://www.radartutorial.eu/01.basics/Radar%20Cross%20Section.en.html)

[//www.radartutorial.eu/01.basics/Radar%20Cross%20Section.en.html](http://www.radartutorial.eu/01.basics/Radar%20Cross%20Section.en.html)

Consequences: in military use stealth techniques (i.e. reflect the power away from the target, in civil use radar reflector

Radar Cross Section of Plane

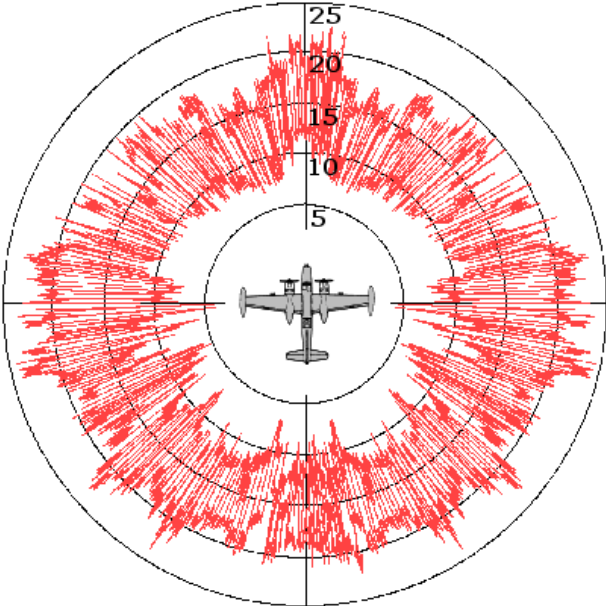

RCS of A-26 Invader
(airplane) CCLi-
cense after https://en.wikipedia.org/wiki/Radar_cross-section

Direction to Target

Is found simply by a directive antenna, i.e. one that only illuminates a certain small angular segment of space

Angular resolution of antenna is about $\Theta_{3dB}, \phi_{3dB} \approx 70^\circ \frac{\lambda}{d}$ with d extend in dimension of interest Gain $G \approx \frac{27000}{\Theta_{3dB} \phi_{3dB}}$ with Θ and ϕ elevation and azimuth.

- Parabolic antenna (round or elliptic), elliptic, if only azimuthal angle is of interest, not elevation. Antenna needs to be mechanically steered
- phased array antenna for electronic beam steering

Block Diagram (Analog Part)

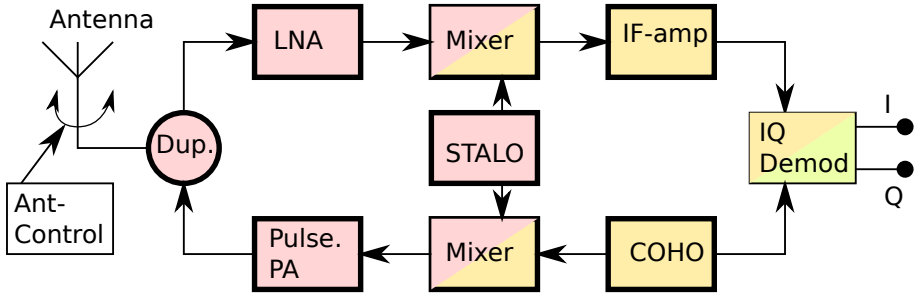

(Mostly) Analog part of a typical pulse Radar

Block Diagram (Digital Part)

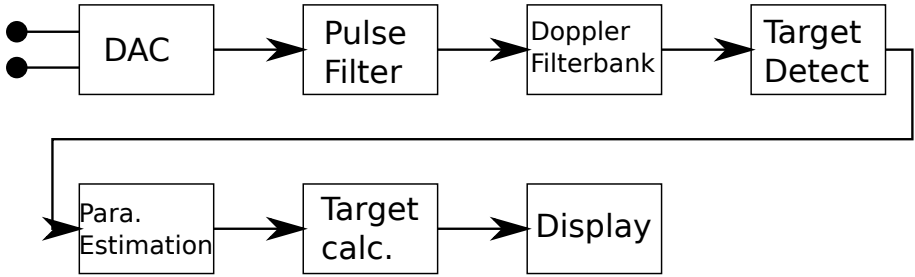

(Mostly) Digital part of a typical pulse Radar

Description to Block Diagram I

Antenna Is the radiating and receiving element. For angular (azimuthal and elevation resolution it is mechanically or electronically steered (see above).

Duplexer Isolate TX from RX

LNA Low Noise Amplifier for Pre-amplification

Pulse and PA Pulse forming and Power amplifier

Mixer Up- and Down-converter from/to Intermediate Frequency

STALO Stable (stabilized) local Oscillator, should have a long coherence length

IP Amp amplifies the intermediate frequency

COHO Coherent Oscillator for the IP Signal

IQ Demodulator demodulated the IF to I and Q in base band and thus also detects the phase of the signal

Description to Block Diagram II

DAC Digital Analog Converter

Pulse Filter (Matched) Filter for base-band filtering

Doppler Filterbank Filterbank to detect the Doppler Shift

Target Detect detects any target and more importantly disregards all the clutter and non-targets

Parameter Estimation e.g. Calman Filtering for target movement estimation

Target Calculation Calculated the target position, speed kind of etc. for later

Display

Distance and Speed (Single Impulse)

Assume ideal modulated (with f_0) pulse

- Received Puls delayed by $\Delta t \Rightarrow \ell = \frac{c}{2\Delta t}$
- Received pulse frequency shifted by $f_D \Rightarrow v_R \approx \frac{1}{2}cf_D/f_0$ ¹
 v_R the velocity directly in direction to the radar.

Examples

Distance/Speed	Δt	f_D @ 10 GHz
1 m(/s)	6,7 ns	67 Hz
10 m(/s)	67 ns	667 Hz
1 km(/h)	6,7 μ s	18,5 Hz
10 km(/h)	67 μ s	185 Hz
100 km(/h)	667 μ s	1852 Hz
1000 km(/h)	6,7 ms	18519 Hz

¹Note this is only approximate, since relativity has been left out and velocity of observer and sender have not been distinctively covered. Further the Doppler shift applies twice: Target as receiver and as transmitter.

Unambiguous Range: Periodic Pulses

What happens if a large target is far away, so far that run time of pulse exceeds pulse repetition interval (T_{PR})

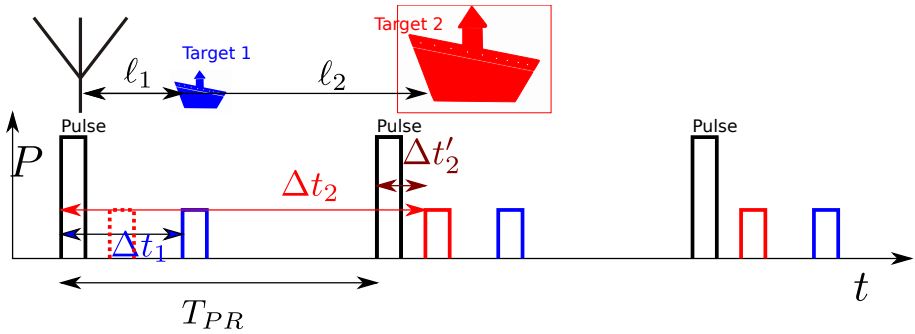

It will be detected as if received after $\Delta t'_2 < \Delta t_2$

Get Rid of Distance Ambiguity

Ambiguity as described above is a problem...

To get rid of it: Change (slightly) the repetition Interval (T_{RP}) from Interval to interval

Clear targets within first range will stay as they where

Targets in higher order intervals will move drastically

Get rid of the moving targets

The Pulse

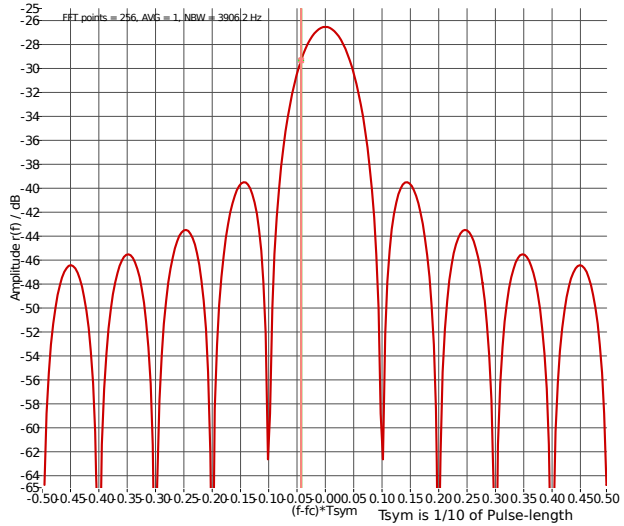

Spectrum of a single pulse with rather steep (rectangular) edges. Observe usual

$\sin(x)/x$ pattern.

- RF Basics
- System Overview
- Fields & Waves
- Transmission Lines
- Practical TL
- 2-Port and S-Parameters
- Matching
- Antennas
- Passives
- Transistors
- Linear Amplifier
- Noise

The Repetition of Pulses

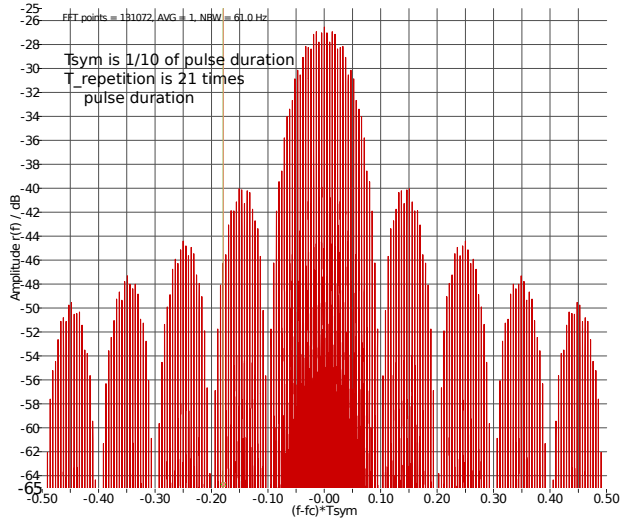

Spectrum of a repeated pulses, observe overlay of $\sin(x)/x$ and comb pattern

The Repetition of Pulses II

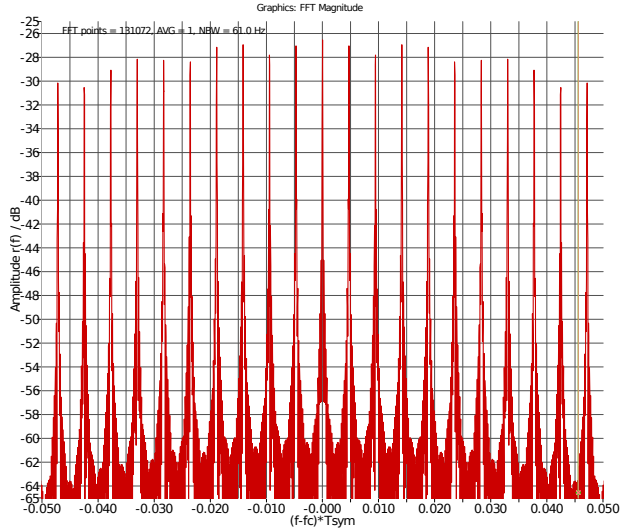

Zoom into the comb spectrum of a periodically repeated pulse pattern.



Noise and Input Filtering

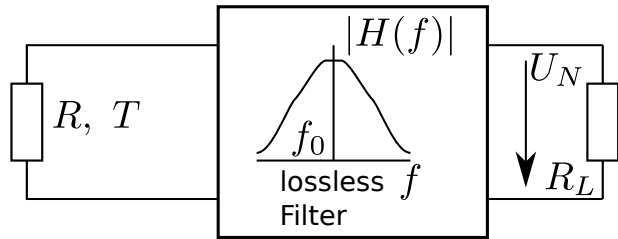

Noise voltage of resistor with temperature T is $U_N = 2\sqrt{kTB_n R}$ with $k = 1.38 \cdot 10^{-23} \text{ Ws/K}$, B_n is noise-bandwidth of filter $B_n \approx 1 \dots 1.5B_{3dB}$.

Noise Figure and Noise Temperature

Noise figure $F = \frac{(S/N)_{in}}{(S/N)_{out}}$ with S, N Signal- and noise power.

$$\begin{aligned}
 F &= \frac{S_{in}}{S_{out}} \frac{N_{out}}{N_{in}} = \frac{1}{G} \cdot \frac{G(N_{in} + \Delta N)}{N_{in}} \\
 &= 1 + \frac{\Delta N}{N_{in}} = 1 + \frac{\Delta N}{kT_0 B_n} = 1 + \frac{kT_n B_n}{kT_0 B_n} \\
 \Leftrightarrow T_n &= (F - 1)T_0 = \frac{\Delta N}{kB_n}
 \end{aligned}$$

Last is the equivalent noise temperature, i.e. the temperature the system (receiver) has, if all noise would be thermal noise (which it is not).

Antenna Noise Temperature

Antenna is the only noise reducing element! (Actually: Noise is kept constant and signal is amplified)

$$T_A = \frac{N_A}{kB_n}$$

Reads weird, but kB_n is the reference noise with receiver bandwidth B_n and N_A is the total noise that the antenna receives consisting of possible thermal noise and more (i.e. man made noise). The key is: The thermal component can be of much lower temperature, as the antenna is possibly pointed to free space with temp. as low as $\approx 3\text{K}$. Thus, T_A can be $\ll T_0$.

System Noise Temperature

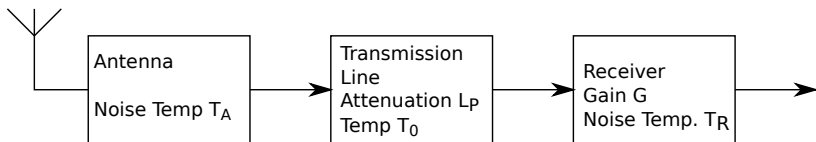

Total noise temperature is thus

$$T_{sys} = T_A + T_0(L_P - 1) + L_P T_R$$

Example: $T_A = 100$ K, $T_0 = 290$ K, $L_P = 2$ dB, $T_R = 150$ K ($F = 1.8$ dB)

Thus

$$T_{sys} = (100 + 290(1.585 - 1) + 1.585 \cdot 150) \text{ K} = 507 \text{ K}$$

Maximum Detectable Range I

With the radar equation we get

$$\left(\frac{S}{N}\right)_{out} = P_t \frac{G_t \sigma G_r \lambda^2}{(4\pi)^3 \ell^4} \frac{1}{kT_{sys} B_n L_t L_{atm}}$$

$$\Leftrightarrow \ell = \sqrt[4]{P_t \frac{G_t \sigma G_r \lambda^2}{(4\pi)^3 \ell^4} \frac{1}{kT_{sys} B_n L_t L_{atm}} \left(\frac{S}{N}\right)_{out}}$$

and depends greatly on...

- Transmitter power doubling power gives 20 % more range, for each dB more power there is 6 % more distance.
- Assume monostatic radar (i.e. $G_t = G_r$) doubling gain gives about 40 % more gain, for each dB more gain (per antenna) there is 12 % more distance.

Maximum Detectable Range II

- Radar Cross section is important, the larger the object, the further you can see it.
- Bandwidth B_n is important, this is dominated by the pulse width: The longer the pulse, the narrower the noise band and thus the longer is range. This is clear, since a longer pulse has proportionally more energy. However, longer pulses limit minimum detectable range and resolution.

Minimum Range and Resolution

- Minimum Range: Receiver is "blinded" during transmission of pulse t_{pulse} and some settling time t_s for e.g. ramping down amplifier, evtl. switching.

$$\ell_{min} = \frac{c}{2}(t_{pulse} + t_s)$$

- To separate targets they must be further apart than the length of half the pulse

$$\ell_{res} = ct_{pulse}$$

Doppler and Ambiguity

- Imagine: When continuously received, the signal from moving target is a periodic signal with frequency $f_0 + f_D$, and in base band only the shift f_D .
- Pulse radar does not continuously receive, it pulses and therefore samples the incoming signal with repetition rate f_{PR} or interval $T_{PR} = 1/f_{PR}$.
- Thus, Doppler signal is sampled with f_{PR} (see also comb spectrum of periodic pulses). So Nyquist's criterion applies with un-ambiguous range of $f_D < \pm \frac{f_{PR}}{2}$.
- Faster signals with higher Doppler shifts fall out of this range and are sub-sampled.

FMCW Radar I

Frequency Modulated Continuous Wave Radar (principle)

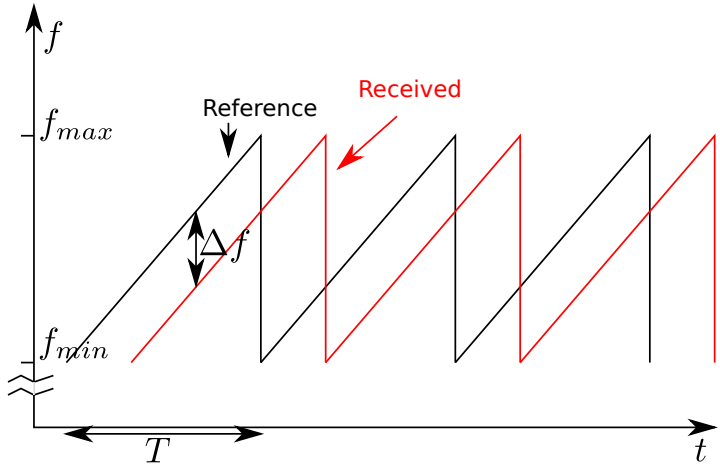

FMCW Radar II

Simple FMCW-radar with linearly modulated chirp. Frequency deviation between send and receive gives:

$$\ell = \frac{\Delta f T}{f_{max} - f_{min}} \cdot \frac{c}{2}$$



More energy in pulse \rightarrow higher dynamic range and distance



no dead time of receiver (only $1/f$ -noise limits min range)



parameters can be calculated from fourier transform of chirp and same rules as for pulse



Doppler results in frequency shifts, which cannot be separated from frequency shift due to delay/ distance

FMCW Radar with Doppler I

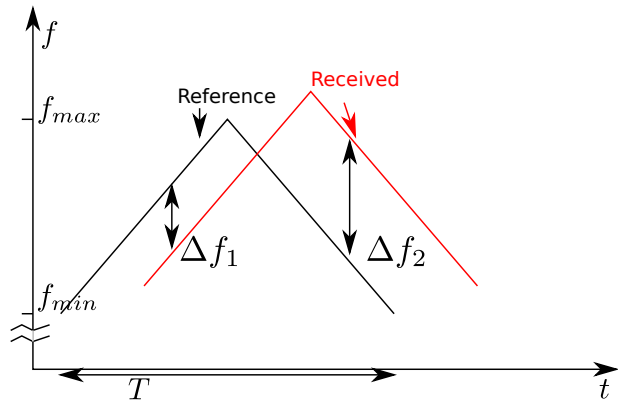

FMCW-radar with linearly modulated chirp with up and down ramp. Δf frequency shift due to delay/ distance.

FMCW Radar with Doppler II

- On up: $\Delta f_1 = \Delta f - f_D$
- On down: $\Delta f_2 = \Delta f + f_D$
- $\Delta f = \frac{\Delta f_1 + \Delta f_2}{2}$
- $f_D = \frac{\Delta f_2 - \Delta f_1}{2}$

Characteristics as above

Simple CW Radar

- Further simplification: Send only continuous signal.



No Timing in signal, thus no distance/ delay can be calculated

- Only Doppler shift can be found (must exceed $1/f$ noise level of oscillator). Thus, only moving objects can be detected.



Very cheap!, requires mainly only oscillator, duplexer, mixer, antenna, some amps and base-band signal processing

References

- RF Basics
- System Overview
- Fields & Waves
- Transmission Lines
- Practical TL
- 2-Port and S-Parameters
- Matching
- Antennas
- Passives
- Transistors
- Linear Amplifier
- Noise



Albrecht Ludloff. *Praxiswissen Radar und Radarsignalverarbeitung*. 4. Aufl. Vieweg+Teubner Verlag, 2008.



radartutorial.eu. URL: <http://www.radartutorial.eu/index.html> (besucht am 19.09.2018).

RF Basics

System
Overview

Fields &
Waves

Transmission
Lines

Practical TL

2-Port and
S-Parameters

Matching

Antennas

Passives

Transistors

Linear
Amplifier

Noise

15 Mixers for Frequency Translation

16 Radar Introduction

17 Oscillators

- A device that generates a (sinusoidal) signal
- Inner device usually into highly non-linear region
- Can be viewed as converter of DC-power to RF-power
- Required in each and every communication system element

This Chapter Will Enable You To

- Understand and describe oscillator operation
- Select different oscillators types according to your application
- Name different strategies to obtain an oscillator
- Design a basic oscillator

Oscillator in the System

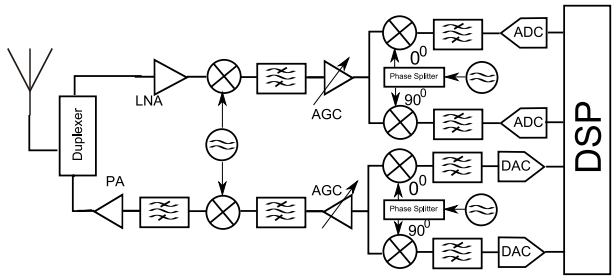

- (Usually) oscillator at two locations (per branch) in the system
- required to provide a local signal
- usually phase locked to some derivation of the input signal (phase locked loop = PLL)

Negative Resistance Oscillator

17 Oscillators

- Negative Resistance Oscillator
- Transistor-Negative Resistance Oscillators
- Dielectric Resonator
- Phase-Noise

Negative Resistance Oscillator

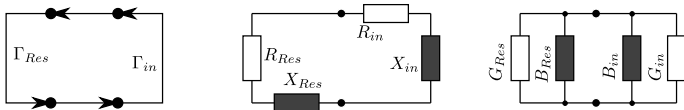

- Obtain a negative (differential/ small signal) resistance
- Negative resistance will de-attenuate the load resistor inside the resonator (res)

$$\Gamma_{res} \geq \frac{1}{\Gamma_{in}} \Rightarrow |\Gamma_{in}| > 1$$

$$\Gamma = \frac{Z - Z_0}{Z + Z_0} \Leftrightarrow Z = Z_0 \frac{1 - \Gamma}{1 + \Gamma}$$

$$\Rightarrow Z = \frac{1 + \Gamma' + j\Gamma''}{1 - \Gamma' - j\Gamma''} = \frac{1 - \Gamma'^2 - \Gamma''^2 + 2j\Gamma''}{(1 - \Gamma')^2 + \Gamma''^2} = \frac{1 - |\Gamma|^2 + 2j\Gamma''}{1 + |\Gamma|^2 - 2\Gamma''^2}$$

if $|\Gamma| > 1$ then $\text{Re}\{Z\} < 0$ and so

$$R_{res} + jX_{res} = -R_{in} - jX_{in}$$

$$G_{res} + jB_{res} = -G_{in} - jB_{in}$$

Practical Negative Resistances: Gunn-Diode

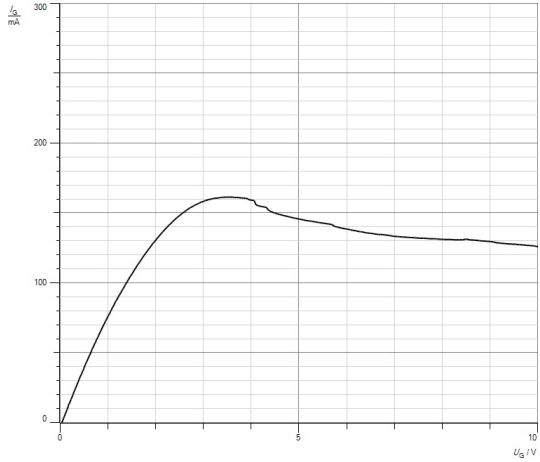

- n-doped Ga As or In P (indirect semiconductor)
- Rise in electron mobility above certain field strength (Gunn-effect)
- Decrease in resistance (as shown)

Gunn-Diode in Resonator II

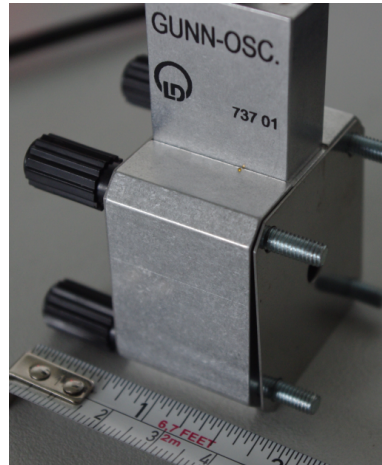
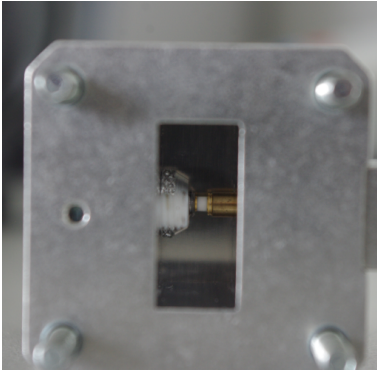

- X-Band (12 GHz) Gunn-Diode in Waveguide
- Right: with resonator

Gunn-Diode in Resonator II

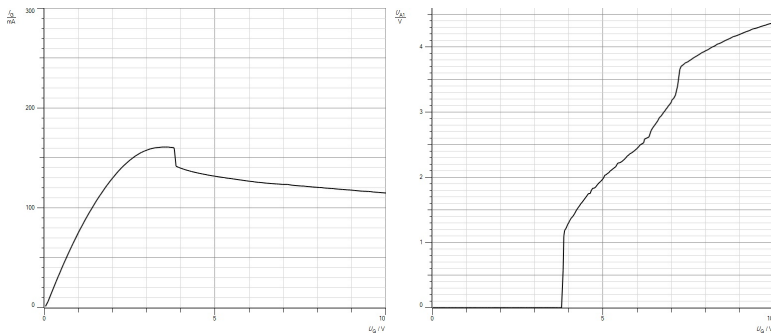

- DC-characteristics of Gunn-Diode in resonator
- RF-Output power (a.u.) of RF-output power

Transistor-Negative Resistance Oscillators

- RF Basics
- System Overview
- Fields & Waves
- Transmission Lines
- Practical TL
- 2-Port and S-Parameters
- Matching
- Antennas
- Passives
- Transistors
- Linear Amplifier
- Noise

17 Oscillators

- Negative Resistance Oscillator
- Transistor-Negative Resistance Oscillators
- Dielectric Resonator
- Phase-Noise

How to Unstabilize a Transistor?

An oscillator will never oscillate, an amplifier always.
Engineering saying

How to Unstabilize a Transistor?

- Apply positive feedback to the transistor
- Usually done by adding inductance to source

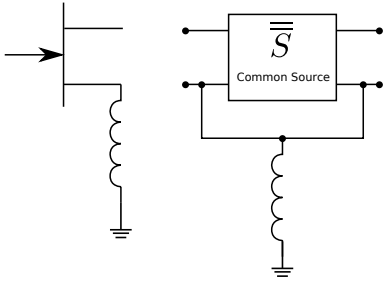

- Calculation of 3-Port S-Parameters from given (Common Source) S-Parameters is required

Three-Port Description of Transistor I

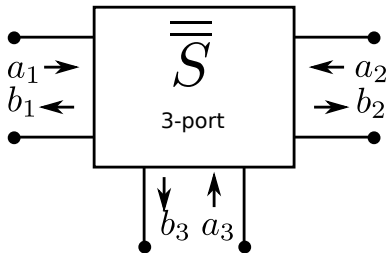

$$\begin{pmatrix} b_1 \\ b_2 \\ b_3 \end{pmatrix} = \begin{pmatrix} \hat{S}_{11} & \hat{S}_{12} & \hat{S}_{13} \\ \hat{S}_{21} & \hat{S}_{22} & \hat{S}_{23} \\ \hat{S}_{31} & \hat{S}_{32} & \hat{S}_{33} \end{pmatrix} \begin{pmatrix} a_1 \\ a_2 \\ a_3 \end{pmatrix}$$

\hat{S}_{ij} are the (to be derived) 3-Port S-Parameters.

Three-Port Description of Transistor II

The sum over row and column must result unity:

$$\sum_{i=1}^3 \hat{S}_{ij} = 1 \quad j = 1,2,3$$

$$\sum_{j=1}^3 \hat{S}_{ij} = 1 \quad i = 1,2,3$$

This is because (without stray caps between ports) after Kirchhoff sum of currents must be zero:

$$\sum_{j=1}^3 (a_i - b_i) = 0 = \sum_{j=1}^3 \left(a_i - \sum_{j=1}^3 \hat{S}_{ij} a_j \right)$$

now choose $a_2 = a_3 = 0$

$$a_1 - \sum_{j=1}^3 \hat{S}_{i1} a_1 = 0$$

$$\sum_{j=1}^3 \hat{S}_{i1} = 1$$

Three-Port Description of Transistor III

For second relation consider voltages at all ports are equal, so current at each port is zero. So $b_i = a_i = a$ and then

$$b_i = \sum_{j=1}^3 \hat{S}_{ij} a_j = \sum_{j=1}^3 \hat{S}_{ij} a = a$$

The voltage at port 3 (source) is $U_3 = a_3 + b_3$. So all other ports have

$$U_1^+ = a_1 - \frac{U_3}{2} = a_1 - \frac{a_3 + b_3}{2}$$

$$U_1^- = b_1 - \frac{U_3}{2} = b_1 - \frac{a_3 + b_3}{2}$$

$$U_2^+ = a_2 - \frac{U_3}{2} = a_2 - \frac{a_3 + b_3}{2}$$

$$U_2^- = b_2 - \frac{U_3}{2} = b_2 - \frac{a_3 + b_3}{2}$$

Three-Port Description of Transistor IV

so the port voltages are

$$U_1 = U_1^+ + U_1^- = a_1 + b_1 - U_3$$

$$U_2 = U_2^+ + U_2^- = a_2 + b_2 - U_3$$

From 2-Port S-Parameters (common source) we still have

$$\begin{pmatrix} U_1^- \\ U_2^- \end{pmatrix} = \begin{pmatrix} S_{11} & S_{12} \\ S_{21} & S_{22} \end{pmatrix} \begin{pmatrix} U_1^+ \\ U_2^+ \end{pmatrix}$$

Together with Kirchhoff's law we now have

$$b_1 - \frac{a_3 + b_3}{2} = S_{11} \left(a_1 - \frac{a_3 + b_3}{2} \right) + S_{12} \left(a_2 - \frac{a_3 + b_3}{2} \right)$$

$$b_2 - \frac{a_3 + b_3}{2} = S_{21} \left(a_1 - \frac{a_3 + b_3}{2} \right) + S_{22} \left(a_2 - \frac{a_3 + b_3}{2} \right)$$

$$0 = a_1 - b_1 + a_2 - b_2 + a_3 - b_3$$

Three-Port Description of Transistor V

with rewriting we get

$$b_1 = S_{11}a_1 + S_{12}a_2 + \sigma_{11} \frac{U_3}{2}$$

$$b_2 = S_{21}a_1 + S_{22}a_2 + \sigma_{22} \frac{U_3}{2}$$

$$b_3 = \frac{\sigma_{12}}{4 - \sigma} a_1 + \frac{\sigma_{21}}{4 - \sigma} a_2 + \frac{\sigma}{4 - \sigma} a_3$$

$$\sigma_{11} = 1 - S_{11} - S_{12}$$

$$\sigma_{22} = 1 - S_{22} - S_{21}$$

$$\sigma_{12} = 1 - S_{11} - S_{21}$$

$$\sigma_{21} = 1 - S_{22} - S_{12}$$

$$\sigma = S_{11} + S_{12} + S_{21} + S_{22} = 2 - \sigma_{12} - \sigma_{21} = 2 - \sigma_{11} - \sigma_{22}$$

Three-Port Description of Transistor VI

$$b_1 = \left(S_{11} + \frac{\sigma_{11}\sigma_{12}}{4 - \sigma} \right) a_1 + \left(S_{22} + \frac{\sigma_{11}\sigma_{21}}{4 - \sigma} \right) a_2 + \frac{2\sigma_{11}}{4 - \sigma} a_3$$
$$b_2 = \left(S_{21} + \frac{\sigma_{22}\sigma_{12}}{4 - \sigma} \right) a_1 + \left(S_{22} + \frac{\sigma_{22}\sigma_{21}}{4 - \sigma} \right) a_2 + \frac{2\sigma_{22}}{4 - \sigma} a_3$$

Three-Port Description of Transistor VII

and finally we have the 3-port S-Parameters

$$\begin{aligned}\hat{S}_{11} &= S_{11} + \frac{\sigma_{11}\sigma_{12}}{4 - \sigma} & \hat{S}_{12} &= S_{12} + \frac{\sigma_{11}\sigma_{21}}{4 - \sigma} & \hat{S}_{13} &= \frac{2\sigma_{11}}{4 - \sigma} \\ \hat{S}_{21} &= S_{21} + \frac{\sigma_{22}\sigma_{12}}{4 - \sigma} & \hat{S}_{22} &= S_{22} + \frac{\sigma_{22}\sigma_{21}}{4 - \sigma} & \hat{S}_{23} &= \frac{2\sigma_{22}}{4 - \sigma} \\ \hat{S}_{31} &= \frac{2\sigma_{12}}{4 - \sigma} & \hat{S}_{32} &= \frac{2\sigma_{21}}{4 - \sigma} & \hat{S}_{33} &= \frac{\sigma}{4 - \sigma}\end{aligned}$$

when setting $b_3 = -a_3$ (short to ground at source) we get

$$\begin{aligned}S_{11} &= \hat{S}_{11} - \frac{\hat{S}_{13}\hat{S}_{31}}{1 + \hat{S}_{33}} & S_{12} &= \hat{S}_{12} - \frac{\hat{S}_{13}\hat{S}_{32}}{1 + \hat{S}_{33}} \\ S_{21} &= \hat{S}_{21} - \frac{\hat{S}_{23}\hat{S}_{31}}{1 + \hat{S}_{33}} & S_{22} &= \hat{S}_{22} - \frac{\hat{S}_{23}\hat{S}_{32}}{1 + \hat{S}_{33}}\end{aligned}$$

Three-Port Description of Transistor VIII

when some impedance Z_S is placed between source and ground, this is modelled by a reflection $\Gamma = (Z_S - Z_0)/(Z_S + Z_0)$ and $a_3 = \Gamma b_3$, in the new scattering matrix $\hat{S}_{33} + 1$ must be replaced by $\hat{S}_{33} - 1/\Gamma$

$$S_{11} = \hat{S}_{11} - \frac{\hat{S}_{13}\hat{S}_{31}\Gamma}{\hat{S}_{33} - \Gamma} \qquad S_{12} = \hat{S}_{12} - \frac{\hat{S}_{13}\hat{S}_{32}\Gamma}{\hat{S}_{33} - \Gamma}$$

$$S_{21} = \hat{S}_{21} - \frac{\hat{S}_{23}\hat{S}_{31}\Gamma}{\hat{S}_{33} - \Gamma} \qquad S_{22} = \hat{S}_{22} - \frac{\hat{S}_{23}\hat{S}_{32}\Gamma}{\hat{S}_{33} - \Gamma}$$

or

$$\Gamma = \frac{S_{11} - \hat{S}_{11}}{\hat{S}_{33}S_{11} - \Delta_1} \qquad \text{with} \qquad \Delta_1 = \hat{S}_{11}\hat{S}_{22} - \hat{S}_{13}\hat{S}_{31}$$

$$\Gamma = \frac{S_{22} - \hat{S}_{22}}{\hat{S}_{33}S_{22} - \Delta_2} \qquad \text{with} \qquad \Delta_2 = \hat{S}_{22}\hat{S}_{33} - \hat{S}_{23}\hat{S}_{32}$$

Three-Port Description of Transistor IX

If we use the limit of passive (reactive) reflections with $|\Gamma| = 1$ then S_{11}, S_{22} are on a circle with

$$\text{Center}_{11} = \frac{\hat{S}_{11} - \Delta_1 \hat{S}_{33}^*}{1 - |\hat{S}_{33}|^2} \qquad \text{Radius}_{11} = \frac{|\hat{S}_{13} \hat{S}_{31}|}{1 - |\hat{S}_{33}|^2}$$

$$\text{Center}_{22} = \frac{\hat{S}_{22} - \Delta_2 \hat{S}_{33}^*}{1 - |\hat{S}_{33}|^2} \qquad \text{Radius}_{22} = \frac{|\hat{S}_{23} \hat{S}_{32}|}{1 - |\hat{S}_{33}|^2}$$

and these circles show what range of S-Parameters are possible.

Three-Port Description of Transistor X

Having derived the 3-port representation of a transistor, the Common Base (Gate) or Common Collector (Drain) 2-Port Parameters can be found by row and column exchange

Common Base/Gate (E/S=Port 1, C/D= Port 2, B/G= Port 3 (common))

$$\begin{array}{lll} \hat{S}_{1i}^{E/S} = \hat{S}_{3i} & \hat{S}_{i1}^{E/S} = \hat{S}_{i3} & \hat{S}_{2i}^{E/S} = \hat{S}_{2i} \\ \hat{S}_{i2}^{E/S} = \hat{S}_{i2} & \hat{S}_{3i}^{E/S} = \hat{S}_{1i} & \hat{S}_{i3}^{E/S} = \hat{S}_{1i} \end{array}$$

Common Collector/Drain (B/G=Port 1, E/S= Port 2, C/D= Port 3 (common))

$$\begin{array}{lll} \hat{S}_{1i}^{C/D} = \hat{S}_{1i} & \hat{S}_{i1}^{C/D} = \hat{S}_{i1} & \hat{S}_{2i}^{C/D} = \hat{S}_{3i} \\ \hat{S}_{i3}^{C/D} = \hat{S}_{i3} & \hat{S}_{3i}^{C/D} = \hat{S}_{2i} & \hat{S}_{i2}^{C/D} = \hat{S}_{i2} \end{array}$$

Use the new $\hat{S}^{C/D}$ or $\hat{S}^{E/S}$ to calculate the 2-Port parameters as in slide VIII

Design of an Oscillator

Summary for design-procedure

- S-Parameter based steps (single frequency)
 - ① De-stabilize the transistor with source-feedback
 - ② Add Source (Base-side) RLC match, maximize for load-side reflection or selected negative resistance value
- S-Parameter based steps (frequency sweep)
 - ① Check frequency performance
 - ② Add resonator (model)
 - ③ Add realistic parasitics and lines etc.
- Spice based steps
 - ① Add bias network (source-DC-ground)
 - ② Check output power

Selection of Transistor and Operating Point



BFP740

Features

2 Features

- Very low noise amplifier based on Infineon's reliable, high volume SiGe:C technology
- $OIP3 = 24.5 \text{ dBm @ } 5.5 \text{ GHz, } 3 \text{ V, } 15 \text{ mA}$
- High transition frequency $f_T = 44 \text{ GHz @ } 3 \text{ V, } 25 \text{ mA}$
- $NF_{min} = 0.85 \text{ dB @ } 5.5 \text{ GHz, } 3 \text{ V, } 6 \text{ mA}$
- Maximum power gain $G_{ms} = 19.5 \text{ dB @ } 5.5 \text{ GHz, } 3 \text{ V, } 15 \text{ mA}$
- Low power consumption, ideal for mobile applications, very common in WLAN Wi-Fi applications
- Easy to use Pb-free (RoHS compliant) and halogen-free standard package with visible leads
- Qualification report according to AEC-Q101 available

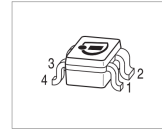

best f_T reached for 4 V, maximum $I_C \leq 45 \text{ mA}$, thus select 4 V, $I_C = 18 \text{ mA}$ for linear operating point design.

Design: De-Stablize

- RF Basics
- System Overview
- Fields & Waves
- Transmission Lines
- Practical TL
- 2-Port and S-Parameters
- Matching
- Antennas
- Passives
- Transistors
- Linear Amplifier
- Noise

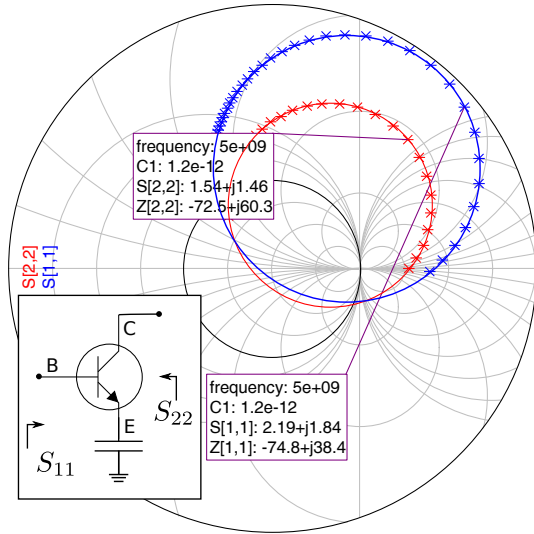

Source-feedback drives S_{11}, S_{22} in Circles

Stability Circles

- RF Basics
- System Overview
- Fields & Waves
- Transmission Lines
- Practical TL
- 2-Port and S-Parameters
- Matching
- Antennas
- Passives
- Transistors
- Linear Amplifier
- Noise

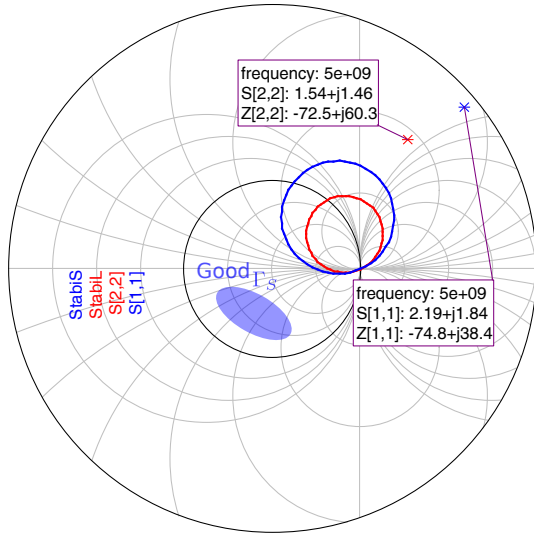

Selected $C = 1.3 \text{ pF}$ for deliverance of high reflection magnitude ($|S_{22}|$).

Select Best Source Reflection

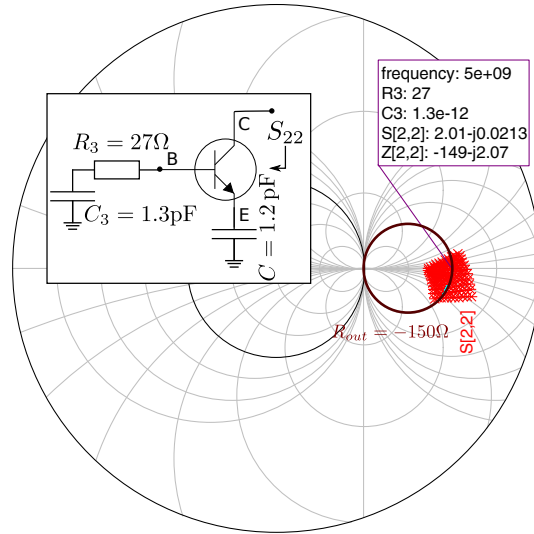

Selected $R_3 = 27 \Omega$, $C_3 = 1.2 \text{ pF}$, delivers output resistance of

$$\text{Re} \{ Z_{out} \} = -150 \Omega$$

Frequency Response

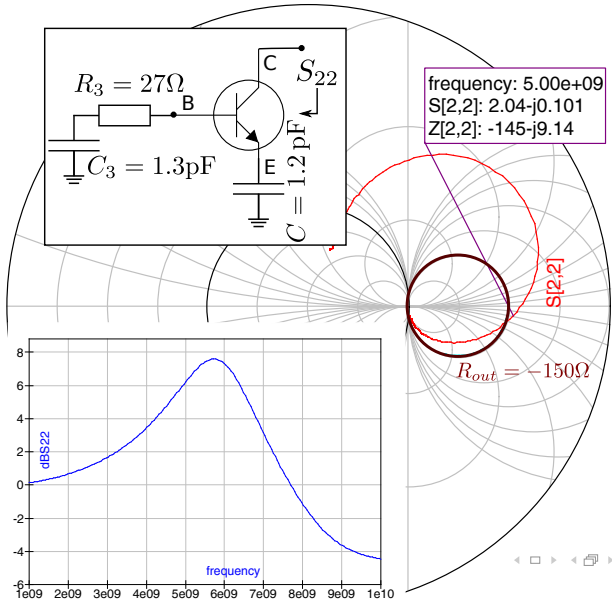

17 Oscillators

- Negative Resistance Oscillator
- Transistor-Negative Resistance Oscillators
- Dielectric Resonator
- Phase-Noise

Resonator Improves Stability

- RF Basics
- System Overview
- Fields & Waves
- Transmission Lines
- Practical TL
- 2-Port and S-Parameters
- Matching
- Antennas
- Passives
- Transistors
- Linear Amplifier
- Noise

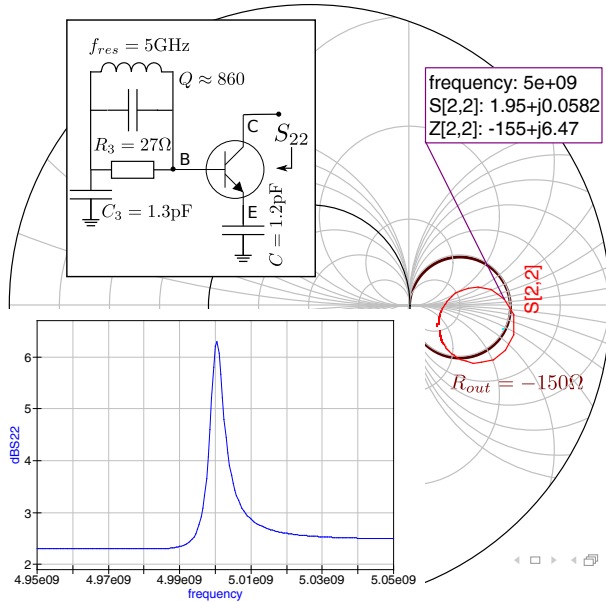

Add Bias-Network

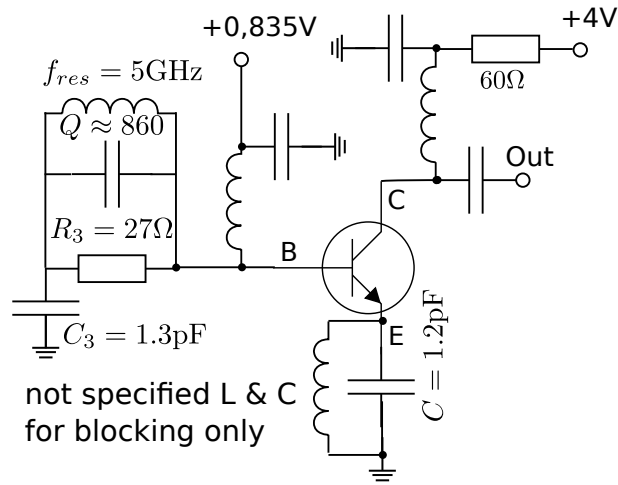

not specified L & C
for blocking only

Preparation for spice simulation, add DC-paths at source and current limiting resistor at DC-supply

Final Result

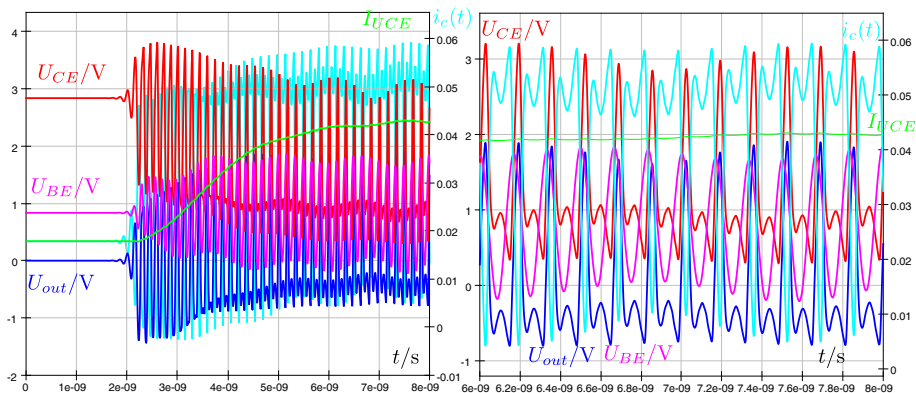

Clear frequency shift (6 GHz), Current limited

Summary and Left-outs

- RF Basics
- System Overview
- Fields & Waves
- Transmission Lines
- Practical TL
- 2-Port and S-Parameters
- Matching
- Antennas
- Passives
- Transistors
- Linear Amplifier
- Noise

- Design with linear and non-linear simulation OK
- Design-steps reliable
- Exact physical model of lines and resonator missing

- RF Basics
- System Overview
- Fields & Waves
- Transmission Lines
- Practical TL
- 2-Port and S-Parameters
- Matching
- Antennas
- Passives
- Transistors
- Linear Amplifier
- Noise

17 Oscillators

- Negative Resistance Oscillator
- Transistor-Negative Resistance Oscillators
- Dielectric Resonator
- Phase-Noise

What is Phase Noise

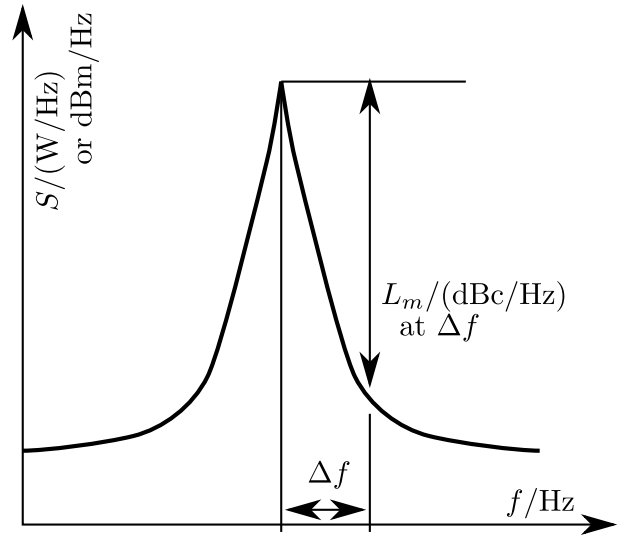

Measured in dBc/Hz at a certain distance from main carrier

What is the Problem? Receiver

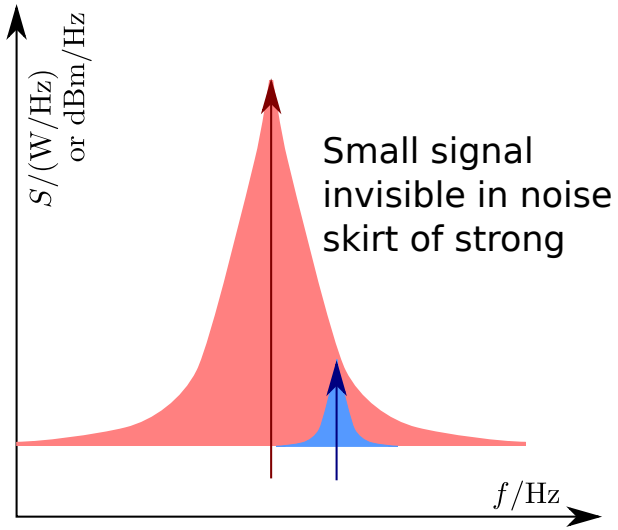

Effect of Blocking can occur

What is the Problem? Transmitter

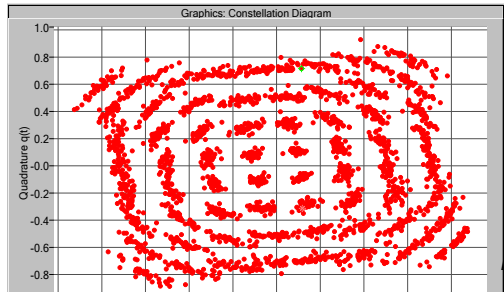
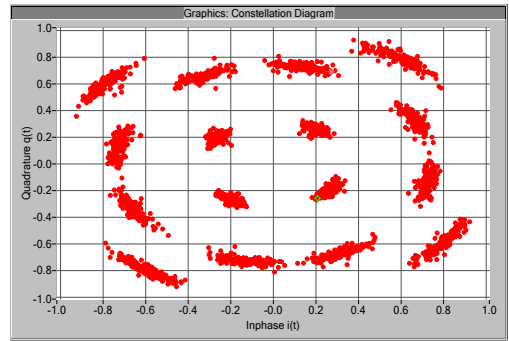
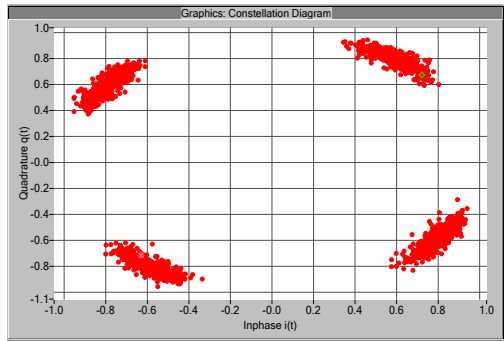

Phasenoise and 60Hz frequency offset in 2560 samples for QPSK, 16-QAM, and 64-QAM.



Limit Noise and Demodulate: PLL

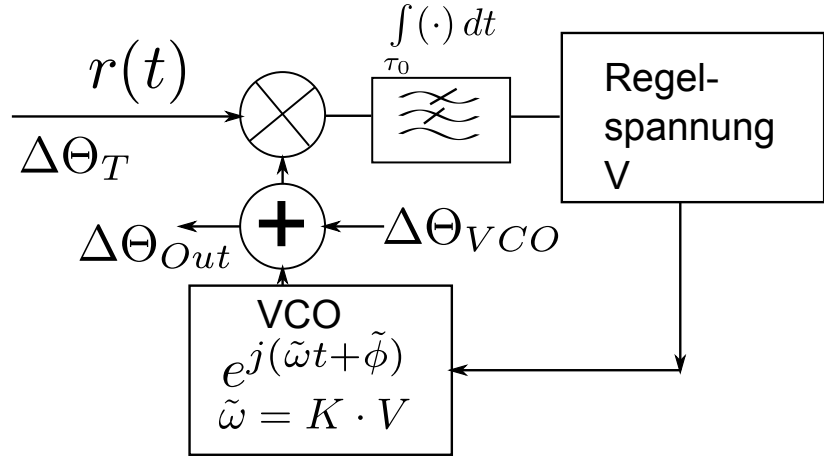

Generic Phase locked loop

Modelling of disturbed oscillator:

$$\Phi(t) = \omega t + \tilde{\phi}(t) = \omega t + K_{VCO} \int_0^t u(\tau) d\tau$$

K_{VCO} : constant gain

$$\omega t + K_{VCO} \int_0^t u_0 d\tau = \omega t + K_{VCO} u_0 t = (\omega + K u_0) t$$

$K/(2\pi)$ frequency adjustment in Hz/V.

PLL Calculations II

- RF Basics
- System Overview
- Fields & Waves
- Transmission Lines
- Practical TL
- 2-Port and S-Parameters
- Matching
- Antennas
- Passives
- Transistors
- Linear Amplifier
- Noise
- Linearities

$$V(j\omega) = \frac{K_{VCO}}{j\omega}$$

First order loop filter

$$G(j\omega) = \frac{1}{1 + j\omega/\omega_g}$$

With $\tau > 1/\omega$ this is low pass with 20 dB per decade

Approximate $\sin \tilde{\phi} \approx \tilde{\phi}$

$$\begin{aligned} H(j\omega) &= \frac{K/(j\omega) \times G(j\omega)}{1 + K/(j\omega) \times G(j\omega)} \\ &= \frac{K}{K + j\omega(1 + j\omega\tau)} \\ &= \frac{K}{K + j\omega - \omega^2\tau} \end{aligned}$$

At output phase disturbance is

$$\begin{aligned} H'(j\omega) &= \frac{1}{1 + V(j\omega)G(j\omega)} \\ &= \frac{j\omega - \omega^2\tau}{K + j\omega - \omega^2\tau} \end{aligned}$$

and all together we have

$$\Delta\Theta_{out} = \frac{K}{K + j\omega - \omega^2\tau} \Delta\Theta_T + \frac{j\omega - \omega^2\tau}{K + j\omega - \omega^2\tau} \Delta\Theta_{VCO}$$

The corner frequencies are

$$\left| 1 + \frac{j\omega}{K} - \omega^2 \frac{\tau}{K} \right|^2 = 2$$
$$\Leftrightarrow \left(1 + \frac{\omega^2 \tau}{K} + \frac{\omega^2}{K^2} \right) = 2$$

$$\omega_{TP} = \pm \sqrt{\frac{1}{\tau} \left(\sqrt{2K^2 + \frac{K}{\tau} + \frac{1}{4\tau^2}} - K - \frac{1}{2\tau} \right)}$$

$$\frac{\left| \frac{j\omega}{K} - \frac{\omega^2 \tau}{K} \right|}{\left| 1 + \frac{j\omega}{K} - \omega^2 \frac{\tau}{K} \right|} = \frac{1}{\sqrt{2}}$$

$$\omega_{HP} = \pm \sqrt{\frac{1}{\tau} \left(K + \frac{1}{2\tau} + \sqrt{2K^2 + \frac{1}{4\tau^2} + \frac{K}{\tau}} \right)}$$

as lower corner frequency of the high-pass

Result

- Low frequency deviation: LF reference oscillator dominates
- High frequency deviation: the VCO dominates

References

RF Basics

System
Overview

Fields &
Waves

Transmission
Lines

Practical TL

2-Port and
S-Parameters

Matching

Antennas

Passives

Transistors

Linear
Amplifier

Noise